



Guideline No.: A-03([202601](#))

# A-03 POLYMER BEARING MATERIALS

Issued date:[January 1,2026](#)

© China Classification Society

## Foreword

China Classification Society (hereinafter referred to as CCS) Product Inspection and Testing Guideline (hereinafter referred to as this Guideline) contains the technical requirements, inspection and testing criteria related to classification and statutory survey of marine products to be applied for CCS approval/inspection.

This Guideline frees the users to adopt other test methods and requirements which are equivalent to or are stricter than this Guideline.

This Guideline is published and updated by CCS, and is released at <http://www.ccs.org.cn>. Your comments or suggestions are welcomed and may be sent to our email addressed [service@ccs.org.cn](mailto:service@ccs.org.cn).

Historical version and release date: A-03(201510)      October 20, 2015

A-03(202204)      April 24,2022

A-03(202402)      February 1,2023

[A-03\(202601\)](#)      [January 1,2026](#)

Main change: The main change as follows:

- a) Renew the items according to the change of CCS Rules and Management Documents.
- b) Delete the description of “under dry-wet alternate conditions” in item 7.3.12(3)⑩.
- c) Clarify that item 7.2 are suitable for initial approval and approval modification.
- d) Modify the item 7.3.1(3),7.3.2(3),7.3.4(3),7.3.5,7.3.7(3),7.3.8(3),7.3.9,7.3.11,7.3.12(2) because of the standards version changed.
- e) Renew the item 5 “Required qualification of the manufacturer applying for approval” with “Technical requirement”.
- f) Renew the form 7.3.2(1) according to the renewed standard.
- g) [Renew according to the IACS UR M85.](#)

## CONTENTS

1 Application .....	4
2 Normative references .....	4
3 Terms and definitions .....	4
4 Drawings and documents .....	5
5 Technical requirements .....	6
6 Materials and components .....	7
7 Type test .....	7
8 Unit/batch inspection .....	19
9 Others .....	19

# POLYMER BEARING MATERIALS

## 1 Application

This Guideline applies to [elastomeric synthetic materials, such as rubber, flexurane, and non-elastomeric synthetic materials, such as nylon, fiber reinforced phenolic resin, nylon \(polyamide\) and modified nylon materials](#) used to manufacture rudder stock bearing, rudder pin bearing, rudder axle bearing and stern shaft bearing. ~~Related technical documents and information for materials of other types are to be submitted to CCS for review.~~

The testing methods involved in the Guideline, where expressly specified by CCS rules, are firstly to comply with the requirements of CCS rules.

## 2 Normative references

2.1 Regulation [2.2.8](#), Chapter 2, PART TWO of CCS Rules for Materials and Welding

2.2 Regulation [3.1.8](#), Chapter 3, PART TWO of CCS Rules for Classification of Sea-going Steel Ships

2.3 Regulation [11.2.5](#), Chapter 11, PART THREE of CCS Rules for Classification of Sea-going Steel Ships

[2.4 UR M85 Type approval testing of synthetic materials for aftmost propeller shaft bearings](#)

## 3 Terms and definitions

~~3.1 Gauge length  $L_0$ : the initial distance between the two mark lines in the middle portion of the test specimen, expressed in millimeter (mm);~~

~~3.2 Test velocity  $v$ : the velocity at which the two pressing plates of the testing machine approach each other or the grippers depart from each other during the test, expressed in millimeter per minute (mm/min);~~

~~3.3 Compressive stress  $\sigma$ : the compressive load borne by the original cross-sectional area of each unit of the test specimen, expressed in megapascal (MPa);~~

~~3.4 Compressive strength  $\sigma_M$ : the maximum stress borne by the test specimen during the test, expressed in megapascal (MPa);~~

~~3.5 Compressive strain  $\epsilon$ : the reduction in length of each unit of original gauge length, expressed by ratio or percentage (%);~~

~~3.6 Tensile stress  $\sigma$ : the tensile load applied on each unit of original cross-sectional area within the gauge length of the test specimen at any given time, expressed in megapascal (MPa);~~

~~3.7 Tensile break stress  $\sigma_B$ : the tensile stress at which the test specimen breaks, expressed in megapascal (MPa);~~

~~3.8 Tensile strength  $\sigma_M$ : the maximum tensile stress borne by the test specimen during the tensile test, expressed in megapascal (MPa);~~

~~3.9 Linear expansion coefficient: the ratio of length variation of the test specimen to its original length at each temperature change of 1 degree centigrade, expressed in  $^{\circ}\text{C}^{-1}$ .~~

#### 4 Drawings and documents

4.1 Enterprises applying for works approval by CCS are to submit necessary plans and technical documents to the local CCS branch organization of the place where the enterprises are located. The related documents are to include at least as-the follow.

- (1) particulars of the manufacturer, including the name, address, history, production capacity, technical and inspection personnel, main products, subordinate relationship, trademark, etc.;
- (2) reference of applicable rules and standards which the product shall comply with
- (3) details of the products for approval;
  - material type
  - lubrication type
  - isotropic or anisotropic behaviour
  - elastomeric or non-elastomeric type
- (4) limitations of the product;
- (5) product specification, technical data sheet, and installation manual including:
  - ① maximum nominal surface pressure
  - ② product dimensions:
    - minimum and maximum dimensions
    - other, if relevant
  - ③ commonly acceptable mating material (type of shaft material, roughness, hardness, etc.)
  - ④ running clearance
  - ⑤ maximum operating temperature
- (36) list of main production equipment;
- (47) list of main test equipment;
- (58) brief production technology of the products for approval;
- (69) description of production processes;
- (10) quality management documents;
- (711) document of entering to the register of enterprise;
- (812) qualification certificate and/or production license;
- (913) manufacturer certificate;
- (4014) quality control scheme (where applicable).

4.2 In addition to the documents required in 4.1, the list of qualified suppliers ~~and~~, the template of Asbestos-free Declaration, asbestos control procedure, safety data sheet, are to be submitted. The list of qualified suppliers is to include suppliers of essential raw materials for production, ~~including caprolactam particles, additives, reinforcing fiber, etc.~~

## 5 Technical requirements

### 5.1 Compressive strength

~~5.1.1 The direction of test for strip-shaped bearings is to be parallel to the extrusion face and the compressive strength is to be more than or equal to 85MPa;~~

~~5.1.2 If the direction of test is to be vertical to the extrusion face, the compressive strength is to be more than or equal to 120MPa;~~

### 5.2 Tensile strength

~~The tensile strength is to be more than or equal to 70MPa.~~

~~5.3 Temperature resistance~~  
~~The test results are not to be less than 80% of the results obtained from tests at normal temperature.~~

### 5.4 Seawater resistance

~~The test results are not to be less than 80% of the results obtained from tests at normal temperature.~~

### 5.5 Volume expansion in lubrication medium

~~The measured volume expansion ratio of test specimens is not to be greater than 3%.~~

### 5.6 Friction factor

~~Friction factor is not greater than 0.25.~~

Physical property of shaft bearing material:

### 5.1 Compressive stress and compressive modulus for non-elastomeric materials

5.1.1 For isotropic materials the compressive stress should not be less than 85 N/mm<sup>2</sup>, the compressive modulus should not less than 850 N/mm<sup>2</sup>.

#### 5.1.2 For anisotropic materials:

(1) For specimens parallel to sheet plane the compressive stress should not be less than 85 N/mm<sup>2</sup>, the compressive modulus should not less than 850 N/mm<sup>2</sup>.

(2) For specimens normal to sheet plane the compressive stress should not be less than 100N/mm<sup>2</sup>, the compressive modulus should not less than 1000 N/mm<sup>2</sup>.

### 5.2 Tensile strength and elongation for elastomeric material.

5.2.1 For rubber the tensile strength should not less than 10 N/mm<sup>2</sup>, the elongation should not less than 150%.

5.2.2 For other material the tensile strength should not less than 30 N/mm<sup>2</sup>, the elongation should not less than 60%.

5.3 Water swelling of materials, only required for water lubrication, should not greater than 3%.

5.4 Oil swelling of materials, only required for oil lubrication, should not greater than 3%.

5.5 Chemical properties change when immersed in water, only required for water.

5.5.1 For anisotropic materials compressive stress and compressive modulus should not less than 80% retention of minimum specified compressive strength and modulus before water immersion.

5.5.2 For elastomeric materials tensile strength and elongation should not less than 80% retention of minimum specified tensile strength and elongation before water immersion.

5.6 Temperature resistance.

5.6.1 For anisotropic materials compressive strength and compressive modulus at test temperature should not less than 80% retention of minimum specified compressive strength and modulus at  $20^{\circ}\text{C} \pm 2^{\circ}\text{C}$ .

5.6.2 For elastomeric materials tensile strength and elongation at test temperature should not less than 80% retention of minimum specified compressive strength and modulus at  $20^{\circ}\text{C} \pm 2^{\circ}\text{C}$ .

5.7 Test data of adhesion to metals (except those not to be adhered to metals) should comply with requirement of manufacturer.

5.8 Change of properties due to aging, only required for elastomeric materials, should not less than 75% retention of Tensile strength and elongation before aging.

5.9 Linear expansion coefficient should comply with requirement of manufacturer.

5.10 Hardness should comply with requirement of manufacturer.

5.11 Impact strength should comply with requirement of manufacturer.

5.12 Density should comply with requirement of manufacturer.

5.13 Friction and wear test data should comply with requirement of manufacturer.

## **6 Materials and components**

~~6.1 Caprolactam particles.~~

~~6.2 Additives such as molybdenum disulfide, graphite, carbon black, etc.~~

~~6.3 Reinforcing fibers such as glass fiber.~~

## **7 Type test**

~~7.1 Type test plan~~

~~7.1.1 Type test plan may be proposed by the applicant and approved by CCS, or presented by CCS and confirmed by the applicant.~~

~~7.1.2 In particular a reduction or complete suppression of the approval tests may be accepted by the Society taking into account the documentation of approval tests performed and a proven track record.~~

~~7.1.3 Type test plan is to cover at least the following aspects:~~

- ~~(1) Range of products for which the approval is being applied (type, specifications, delivery condition);~~

- (2) Basis for type test plan;
- (3) Type, specifications, quantity, delivery condition etc. of the typical samples selected for type test;
- (4) Type test items and requirements for the tests;
- (5) Sampling positions, schematic diagram and description;
- (6) Recommended test organization which should comply with the requirements of the society;
- (7) Other aspects .to be indicated.

76.2 Selection of typical samples for type test

6.2.1 ~~For initial recognition and~~ For approval modification of adding material type and initial recognition, type approval testing should be conducted.

6.2.2 At least three representative diameter products of each kind of product, same chemical composition and same reinforcement material (for composites only), shall be selected for type approval testing. ~~products of the maximum diameter and maximum thickness are to be selected from the products within the scope of application as the typical samples for approval test.~~

6.2.3 For the wear test, one representative product may be selected.

76.3 Type test items and requirements

6.3.1 Tests 5.1 to 5.8 should comply with the requirements of Table 6.3(1) and Table 6.3(2).

Table 6.3(1) Non-elastomeric materials

<u>Test items</u>	<u>Test standard</u>	<u>Number of specimens</u>	<u>Test conditions</u>
<u>Compressive strength[N/mm<sup>2</sup>]</u>	<u>ISO 604: 2002 (GB/T 1041-2008); ASTM D695-2015</u>	<u>Test at least five specimens for each sample in the case of isotropic materials. Test at least ten specimens, five normal to and five parallel to sheet plane, for each sample in the case of anisotropic materials.</u>	
<u>Compressive modulus [N/mm<sup>2</sup>]</u>	<u>ISO 604: 2002 (GB/T 1041-2008); ASTM D695-2015</u>	<u>Test at least five specimens for each sample in the case of isotropic materials. Test at least ten specimens, five normal to and five parallel to sheet plane, for each sample in the case of anisotropic materials.</u>	
<u>Water swelling [volume, %], only required for water lubrication</u>	<u>ISO 175: 2010</u>	<u>Test at least three specimens for each sample in the case of test temperature.</u>	<u>Four weeks in substitute ocean water (ASTM D1141) at 20°C ± 2°C and maximum temperature (60°C±2°C or advised maximum working temperature by manufacturer, whichever is higher). At least three specimens with dimension:50x50xt mm, t is min. 4 mm or the min. thickness</u>

A-03(202601) POLYMER BEARING MATERIALS

			<a href="#">of the bushing product. Testing immediately after extraction (wet condition).</a>
<a href="#">Oil swelling (for oil lubricated system) [volume, %], only required for oil lubrication</a>	<a href="#">ISO 175: 2010</a>	<a href="#">3</a>	<a href="#">Four weeks in oil No.3(ISO 1817:2022) at 20°C ± 2°C. At least three specimens with dimension:50x50xt mm, t is min. 4 mm or the min. thickness of the bushing product. Testing immediately after extraction (wet condition).</a>
<a href="#">Compressive strength and modulus change when immersed in water, only required for water lubrication</a>	<a href="#">ISO 604: 2002 (GB/T 1041-2008); ASTM D695- 2015</a>	<a href="#">Test at least five specimens for each sample in the case of isotropic materials. Test at least ten specimens, five normal to and five parallel to sheet plane, for each sample in the case of anisotropic materials.</a>	<a href="#">Four weeks in substitute ocean water (ASTM D1141) at 20°C ± 2°C.</a>
<a href="#">Temperature resistance</a>	<a href="#">ISO 604: 2002 (GB/T 1041-2008); ASTM D695- 2015</a>	<a href="#">Test at least five specimens for each sample in the case of isotropic materials. Test at least ten specimens, five normal to and five parallel to sheet plane, for each sample in the case of anisotropic materials.</a>	<a href="#">Compressive strength and compressive modulus at maximum temperature (60°C±2°C or advised maximum working temperature by manufacturer, whichever is higher).</a>

Note:

- [1. Other testing standards may also be accepted, provided that they are suitable for testing of the synthetic material selected for application in aftmost propeller shaft bearings.](#)
- [2. The number of specimens is to be prepared for each sample.](#)

Table 6.3(2) Elastomeric materials

<a href="#">Test items</a>	<a href="#">Test standard</a>	<a href="#">Number of specimens, at least</a>	<a href="#">Test conditions</a>
<a href="#">Tensile strength [N/mm<sup>2</sup>]</a>	<a href="#">ISO 37:2017; Method A of ASTM D412-16(2021); ASTM D638-22</a>	<a href="#">3</a>	
<a href="#">Elongation (%)</a>	<a href="#">ISO 37:2017; Method A of ASTM D412-16(2021); ASTM D638-22</a>	<a href="#">3</a>	
<a href="#">Hardness</a>	<a href="#">ISO 48-4:2018; ASTM D2240-15(2021)</a>	<a href="#">3</a>	
<a href="#">Water swelling [volume, %], only required for water lubrication</a>	<a href="#">ISO1817:2022</a>	<a href="#">3</a>	<a href="#">Four weeks in substitute ocean water (ASTM D1141) at 20°C ± 2°C and maximum temperature (60°C±2°C or advised maximum working temperature by manufacturer, whichever is higher). At least three specimens with dimension:50x50xt mm, t is min. 4 mm or the min. thickness of the bushing product. Testing immediately after extraction (wet condition).</a>
<a href="#">Oil swelling (for oil lubricated system) [volume, %], only required for oil lubrication</a>	<a href="#">ISO1817:2022</a>	<a href="#">3</a>	<a href="#">Four weeks in oil No.3(ISO 1817) at 20°C ± 2°C. At least three specimens with dimension:50x50xt mm, t is min. 4 mm or the min. thickness of the bushing product. Testing immediately after extraction (wet</a>

A-03(202601) POLYMER BEARING MATERIALS

<u>Tensile strength and elongation change when immersed in water, only required for water lubrication</u>	<u>ISO 37:2017; Method A of ASTM D412-16(2021); ASTM D638-22</u>	<u>3</u>	<u>condition).</u> <u>Four weeks in substitute ocean water (ASTM D1141) at 20°C ± 2°C.</u>
<u>Temperature resistance</u>	<u>ISO 37:2017; ISO 7743:2017; Method A of ASTM D412-16(2021); ASTM D638-22</u>	<u>3</u>	<u>Tensile strength and elongation at maximum temperature (60°C±2°C or advised maximum working temperature by manufacturer, whichever is higher).</u>
<u>Adhesion to metals (except those not to be adhered to metals) [N/mm<sup>2</sup>]</u>	<u>ISO 813:2019; ISO 1827:2022</u>	<u>3</u>	
<u>Change of properties due to aging [%]</u>	<u>ISO 37:2017; ISO 7743:2017; Method A of ASTM D412-16(2021); ASTM D638-22</u>	<u>3</u>	<u>After oven aging for tension and elongation tests. Test specimens shall be subjected to circulating air at maximum temperature (60°C±2°C or advised maximum working temperature by manufacturer, whichever is higher) for 96 hours. Tension and elongation tests shall be performed not less than 20 hours but more than 48 hours after removal from the aging environment.</u>

Note:

1. Other testing standards may also be accepted, provided that they are suitable for testing of the synthetic material selected for application in aftmost propeller shaft bearings.
2. The number of specimens is to be prepared for each sample.

Unless otherwise stated, the test specimens for various tests are to be arranged into groups consisting of at least five pieces, and five effective test specimens within the same batch are to be ensured.

7.3.1 Compressive stress and compressive modulus of elasticity (25% strain)

(1) Shapes and dimensions of test specimens

- ⊕ For fiber reinforced materials, the test specimens are to be in the shape of rectangular parallelepiped (type I) or cylinder (type II). The dimensions of test specimens are to be in accordance with the requirements in Table 7.3.1.

Dimensions of Extrusion Test Specimens Table 7.3.1

<b>Dimension-symbol</b>	<b>Type I (rectangular parallelepiped)</b>		<b>Dimension-symbol</b>	<b>Type II (cylinder)</b>	
	<b>General test-specimen</b>	<b>Arbitration test-specimen</b>		<b>General test-specimen</b>	<b>Arbitration test-specimen</b>
Width b	10-14	10±0.2	--		
Thickness d	4-14	10±0.2	Diameter D	4-16	10±0.2
Height H	$\frac{\lambda}{3.46}d$	30±0.5	Height H	$\frac{\lambda}{4}D$	25±0.5

For type I test specimens, when the thickness d is less than 10mm, (10±0.2) mm is to be taken as the width b; when the thickness d is greater than 10mm, the thickness value is to be taken as the width b. 10 is to be taken as the λ value when compressive strength is determined. Where instability happens during the test, 6 is to be taken as the λ value. λ is to be 15 or determined according to the readings of deformation

measuring instrument when the compressive modulus of elasticity is determined.

- ② For other materials, the test specimens are to be in the shape of prism, circular cylinder or tube. The dimensions of test specimens are to comply with the inequation below:

$$\varepsilon_e^* \leq 0.4 \frac{x^2}{l^2}$$

$\varepsilon_e^*$ ——the maximum nominal compressive strain occurring during the test, expressed by ratio;—

$x$ ——depends on the shape of the test specimen, diameter of circular cylinder, outer diameter of pipe or thickness of prism (minimum side of the cross-sectional area);—

$l$ ——thickness of the test specimen measured along the direction parallel to the axis of compressive force

Note: The ratio for measuring compressive modulus of elasticity is recommended to be  $x/l > 0.08$ . The ratio for extrusion test is recommended to be  $x/l > 0.8$ , which is equivalent to 25% of the maximum compressive strain.—

- ③ The dimensional measurement of test specimens is to be accurate to 0.01mm.

## (2) Test requirements

- ① For extrusion test of fiber reinforced materials, when modulus of elasticity is measured,  $v=2\text{mm/min}$  and when compressive strength is measured,  $v=1\text{--}6\text{mm/min}$  ( $v=2\text{mm/min}$  for arbitration test).

For extrusion test of other materials, when modulus of elasticity is measured,  $v=0.021$  and when compressive strength is measured,  $v=0.11$ .

- ② Compressive modulus is to be calculated by the formula below:

$$E_e = \frac{\sigma_2 - \sigma_1}{\varepsilon_2 - \varepsilon_1}$$

——  $E_e$ : compressive modulus, expressed in megapascal (MPa);

$\sigma_1$ : stress value measured at stress  $\varepsilon_1=0.0005$ , expressed in megapascal (MPa);

$\sigma_2$ : stress value measured at stress  $\varepsilon_1=0.0025$ , expressed in megapascal (MPa).

- ③ If the test specimen is not broken down during extrusion, the stress value corresponding to 25% of compressive stain is to be taken as the compressive strength of the material.—

- ④ For fiber reinforced anisotropic materials, extrusion test is to be carried out along the direction in which the product bears the compressive force when the product is being used. Where the consistence between such directions cannot be assured, the test is to be carried out along the two principal directions.—

- ⑤ The test results are to meet the following requirements. Compressive strength: the direction of test for strip-shaped bearings is to be parallel to the extrusion face and the compressive strength is to be more than or equal to 85MPa; the direction of test for bearings of other shapes is to be vertical to the extrusion face and the compressive strength is to be more than or equal to 120MPa. Compressive modulus: compressive modulus is to be more than or equal to 1500MPa.

- (3) Other requirements are to be in accordance with GB/T1041 Plastics Determination of Compressibility (or ISO 604) and GB/T1448 Test Method for Compressibility of Fiber Reinforced Plastics (or ASTM D695) respectively.

## 7.3.2 Tensile strength

- (1) Shapes and dimensions of test specimens

① The shapes of test specimens are as shown in Fig. 1 and Fig. 2.

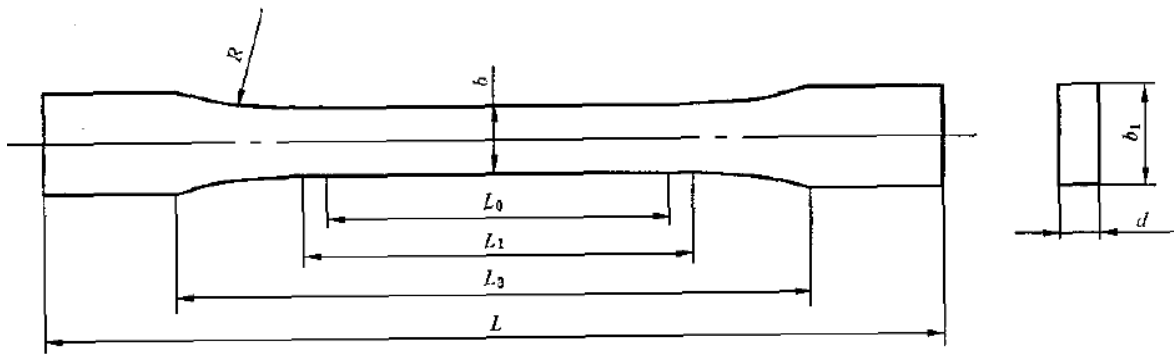

Fig. 1 Diagram of Tensile Test Specimen (type 1A, type 1B, type 1BA, type 1BB and type I)

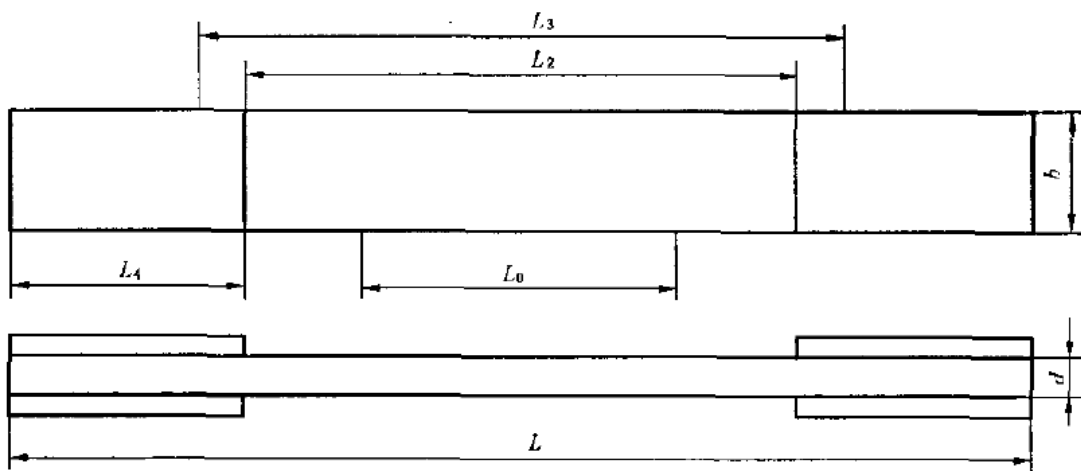

Fig. 2 Diagram of Tensile Test Specimen (type II)

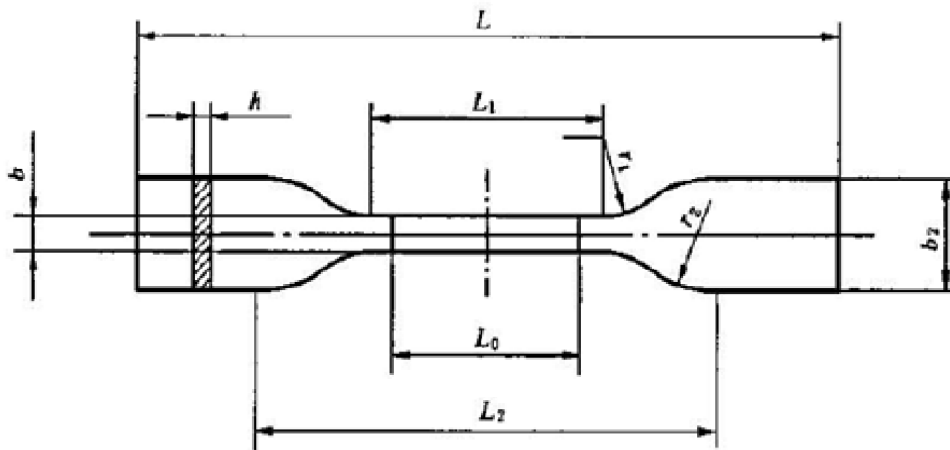

Fig. 3 Diagram of Tensile Test Specimen (5A, 5B)

② The dimensions of test specimens are to comply with the requirements of Table 7.3.2(1).

Dimensions of Tensile Test Specimens

Table 7.3.2(1)

A-03(202601) POLYMER BEARING MATERIALS

Symbol	Description	Non fiber reinforced materials						Fiber reinforced materials	
		1A	1B	1BA <sup>Ⓢ</sup>	1BB <sup>Ⓢ</sup>	5A <sup>Ⓢ</sup>	5B <sup>Ⓢ</sup>	Type I	Type II
L	Overall length (minimum)	≥170 <sup>Ⓢ</sup>	≥150 <sup>Ⓢ</sup>	≥75	≥30	≥75	≥35	180	250
L <sub>0</sub>	Gauge length	75.0±0.5	50.0±0.5	25±0.5	10±0.2	20±0.5	10±0.2	50±0.5	100±0.5
L <sub>1</sub>	Length of the middle-parallel section	80±2	60.0±0.5	30±0.5	12±0.5	25±1	12±0.5	55±0.5	—
L <sub>2</sub>	Spacing between end-reinforcing sheets	—	—	—	—	—	—	—	150±5
L <sub>3</sub>	Length of the wide-parallel section	109.3±3.2 <sup>Ⓢ</sup>	108±1.6 <sup>Ⓢ</sup>	58±2	23±2	—	—	—	—
L <sub>4</sub>	Length of end-reinforcing sheets (minimum)	—	—	—	—	—	—	—	50
b	Width of the middle-parallel section	10.0±0.2		5±0.5	2±0.2	4±0.1	2±0.1	10±0.2	25±0.5
b <sub>1</sub>	Width of ends	20.0±0.2		10±0.5	4±0.2	12.5±1	6±0.5	20±0.5	—
R	Radius	24±1	60±0.5	≥30	≥12	—	—	75	—
r <sub>1</sub>	Small radius	—		—	—	8±0.5	3±0.1	—	—
r <sub>2</sub>	Large radius	—		—	—	12.5±1	3±0.1	—	—
d <sup>Ⓢ</sup>	Thickness	4.0±0.2		≥2	≥2	≥2	≥1	2-10	2-10
	Spacing between grippers	115±1		L <sub>3</sub> <sup>+2</sup> <sub>-0</sub>	L <sub>3</sub> <sup>+1</sup> <sub>-0</sub>	50±2	20±2	115±5	170±5

Note:

①: for some materials, the length of the handle ends of test specimens need to be increased (e.g. 200mm) to avoid fracture or sliding of the test specimen clipped by the grippers;

②:  $L_3 = L_0 + [4R(b_1 - b) - (b_1 - b)^2]^{1/2}$ ;

③: Where type I standard test specimens cannot be used for some reason, test specimens of type 1Ba, 1BB, 5A or 5B may be used;

④: Reference may be made thereto for test specimens of thickness less than 2mm.

⑤: The dimensions are to accurate to 0.01mm for type I and type II test specimens and to 0.02mm for the test specimens of other types.

(2) Test requirements

① Test velocity

The test velocity is to be 10mm/min for type I test specimens and 5mm/min for type II test specimens. The test velocity for other test specimens is to be selected from Table 7.3.2(2) according to the recommendations of the manufacturer.

~~Recommended Test Velocity~~ ~~Table 7.3.2(2)~~

<del>Velocity mm/min</del>	<del>1</del>	<del>2</del>	<del>5</del>	<del>10</del>	<del>20</del>	<del>50</del>
<del>Permissible tolerance</del>	<del>±20</del>	<del>±20</del>	<del>±20</del>	<del>±20</del>	<del>±10</del>	<del>±10</del>
<del>%</del>						

~~② The tensile strength is to be more than or equal to 70MPa.~~

~~(3) Other test requirements are to be in accordance with ISO527-2 Plastics Determination of Tensile Properties Part 2: Test Conditions for Moulded and Extruded Plastics and GB/T1447 Test Method for Tensile Properties of Fiber Reinforced Plastics (or ISO527.4) respectively.~~

### 7.3.3 Temperature resistance

~~Compressive strength and compressive modulus of elasticity are to be measured after the test specimens have been heated to 50 °C and maintained at the same for an hour in accordance with the requirements of 7.3.1. The relevant test results are not to be less than 80% of the results obtained from tests at normal temperature. The test specimens are to be tested in 50 °C environment.~~

### 7.3.4 Volume expansion in seawater

~~(1) Each group is to include at least three test specimens which may be of tubular or plate strip shape and of 50×50×tmm dimensions. 4mm or the minimum thickness of the materials within the scope of application for approval is to be taken as the value of t.~~

#### ~~(2) Test requirements~~

~~① Seawater is to comply with the requirements of ASTM D1141.~~

~~② Tests are to be carried out in 20 °C and 80 °C liquid environments respectively. The allowable deviation of test temperature is to be ±2 °C and soak time four weeks.~~

~~③ The volume of seawater is to be calculated according to the surface area of the test specimen and to be no less than 8ml per square centimeter.~~

~~④ The test specimen is to be fully soaked in seawater and a weight may be attached to the test specimen when necessary. The three test specimens of one group may be soaked in the same container; however, contact between the surfaces of the three test specimens or contact of the test specimens with the container wall and attached weight is not allowed.~~

~~⑤ The soaking seawater is to be agitated at least once every 24 hours and replaced once every 7 days.~~

~~⑥ The volumetric change rate of test specimens is to be measured at room temperature. If the soaking temperature is not equal to the room temperature, the test specimens may be rapidly transferred into and soaked in fresh seawater at room temperature for 15-30 minutes prior to the measurement.~~

~~⑦ The measured volume expansion ratio is not to be greater than 3%.~~

~~⑧ For the materials with applied surface pressures over 5.5N/mm<sup>2</sup>, alternate wetting and drying soaking test at 20 °C is to be performed. With the four weeks' soak time, the test specimens are to be soaked in the seawater for three days and placed in the air for three days, and then soaked again in the seawater for three days and placed in the air for three days, and so repeatedly in circles. The test is to start from three days of soaking and end at three days of soaking. The measured volume expansion ratio of test specimens till the end of the test is not to be greater than 3%.~~

~~(3) Other requirements are to be in accordance with ISO175 Plastics Determination of Liquid and Chemical Agents Resistance~~

#### ~~7.3.5 Volume expansion in oil (20 °C, four weeks)~~

~~The test specimens, test process and results are to be the same as those described in 7.3.4. Oils specified in ISO1817 are to be selected as the soaking medium according to the manufacturers' requirements. Only the volume expansion ratio at the soaking temperature 20 °C is to be measured.~~

~~Other requirements are to be in accordance with ISO175 Plastics Determination of Liquid and Chemical Agents Resistance.~~

#### ~~7.3.6 Seawater resistance (four weeks, compressive stress and modulus at 25% of strain)~~

~~After four weeks' soaking in 20 °C seawater described in 7.3.4, the test specimens are to be removed from the seawater, dried and extrusion tested in accordance with 7.3.1 to measure the compressive strength and compressive modulus of elasticity. The test results are not to be lower than 80% of the results measured at normal temperature.~~

#### ~~7.3.7~~ 3.2 Linear expansion coefficient

(1) The test specimens are to be of a length within the range of 50mm~125mm and have circular, square or rectangular section to allow easy placement into the dilatometer and avoid excessive friction. The cross-sectional area of the test specimen is to be sufficient large to prevent bending and torsion. The section of the test specimen is normally 12.5mm×6.3mm or 12.5mm×3mm in dimensions and 12.5mm or 6.3mm in diameter. The test specimen is to be cut even on both ends along the direction vertical to its long axis. Where the test specimen contract inside the dilatometer, smooth and thin iron or aluminum metal sheets are to be used to fix and position them in the dilatometer. The thickness of these metal sheets is to be within the range of 0.3mm~ 0.5mm.

(2) Test requirements

- ① Measure the two condition-adjusted test specimens using caliper to an accuracy of 0.02mm.
- ② Attach the iron sheets to the bottom of the test specimens to avoid contraction and re-measure the length of the test specimens.
- ③ Use the same dilatometer for all test specimens and place the same in -30 °C environment. If a liquid bath is used, it is to be ensured that the top of test specimens is 50mm below the liquid surface. Maintain the liquid bath temperature at a constant value of (-32~-28 °C) ±0.2 °C and wait to allow equilibrium of the temperature of test specimens with that of the constant-temperature bath. Record the measured temperatures and the dilatometer readings 5min~10min after the readings of dilatometer become stable.
- ④ Place the quartz dilatometer into -30 °C constant-temperature bath with care while avoiding vibration and swaying. Repeat the operation of step ③.
- ⑤ Measure the final length of the test specimens at room temperature.
- ⑥ If the difference between the absolute values of expansion and contraction per degree centigrade of the test specimens is greater than 10% of the average, the causes are to be analyzed and eliminated if possible. Then the test is to be re-conducted until the requirements are met.
- ⑦ The average linear expansion coefficient per degree centigrade of the test specimens is to be calculated by the formula below:

$$\alpha = \frac{\Delta L}{L_0 \cdot \Delta T} \quad ^\circ\text{C}^{-1}$$

$\alpha$ —linear expansion coefficient,  $^\circ\text{C}^{-1}$

$\Delta L$ —arithmetic average of the expansion and contraction of the test specimen, expressed in mm

$L_0$ —original length of test specimens, expressed in mm

$\Delta T$ —average value of the temperature differences between two constant-temperature baths

The test results are expressed in the arithmetic average values of one test specimen group.

- (3) Other requirements are to be in accordance with GB/T1036 Plastics-Determination of Linear Expansion Coefficient at  $-30\text{ }^\circ\text{C}\sim 30\text{ }^\circ\text{C}$  by Quartz Dilatometer Method (or ASTM D696).

7.3.86.3.3 Hardness test for elastomeric materials should comply with Table 6.3(2), Hardness test for non-elastomeric materials should comply with following requirements:

- (1) Brinell hardness is to be measured for the fiber reinforced materials. The thickness of the test specimens is to be no less than 1.5mm. The test specimens are to be sized to ensure a minimum distance of 3mm from any indentationextrusion point to the edge of the test specimens and from one indentationextrusion point to another. 10 tests are to be performed when the hardness is more than or equal to 60, 16 tests are to be performed when the hardness is more than or equal to 50 and less than 60, 22 tests are to be performed when the hardness is more than or equal to 40 and less than 50 and 29 tests are to be performed when the hardness is more than or equal to 30 and less than 40. The arithmetic average values of the measurements of one test specimen group are to be taken as the final results. The test is to be carried out on the force bearing surface of the material.
- (2) Rockwell hardness is to be measured for other materials. The thickness of the test specimens is to be no less than 6mm. The test specimens are to be sized to ensure a minimum distance of 10mm from any indentationextrusion point to the edge of the test specimens and from one indentationextrusion point to another. Each test specimen is to undergo at least five measurements. The Rockwell hardness value is to be within the range of 50~115 and values beyond this range are incorrect and to be re-measured using the adjacent gauge. The test is to be carried out on the force bearing surface of the material.
- (3) Other requirements are to be in accordance with GB/T3398.2 Plastics-Determination of Hardness—Part 2: Rockwell Hardness (or ISO2039.2) and GB/T3854 Test Method for Barcol Hardness of Reinforced Plastics (or ASTM D2583) respectively.

7.3.96.3.4 Impact strength

Impact test is to be carried out in compliance with the requirements of GB/T1043.1 Plastics-Determination of Charpy Impact Properties Using Simply Supported Beams—Part 1 Non-instrumented Impact Test (or ISO179) and GB/T7984 Method for Testing Impact Toughness of Fiber Reinforced Plastics Composites Using Simply Supported Beam respectively.

7.3.10 PV limit value

~~For materials intended to be used on stern shaft bearing, the PV limit value is to be measured in accordance with the specific requirements in GB7948 Test Method for PV Limit of Plastic Bearings.~~

7.3.116.3.5 Density

Density is to be measured in accordance with GB/T1033.1 Plastics-Determination of the Density of Non-foamed Plastics—Part 1 Immersion Method, Liquid Pyknometer Method and Titration Method (or ISO1183.1), GB/T 533 Rubber, vulcanized or thermoplastic-Determination of density(or ISO2781).

7.3.126.3.6 Friction and wear test

(1) Friction ~~coefficient~~~~factor~~ is to be measured during the test and ~~not greater than 0.25~~~~should comply with requirement of manufacture.~~

(2) ~~The friction factor and wear rate of stern shaft bearings are to be measured in accordance with the requirements of GB/T3960.~~For aftmost propeller shaft bearings, the test is to comply with ASTM G77-17 or other testing standards, and following requirements:

① Material of the shaft used in the test and its properties are to be specified and shall be equivalent to typical mating material e.g. alloyed steel or stainless steel or copper alloy.

② Diameter of shaft: the shaft diameter depends on the bearing size. The running clearance should be considered in the wear test.

③ Motion of shaft: continuous rotation. Circumferential velocity should be 6 m/s for oil or water lubrication and should be 3 m/s for grease lubrication.

④ Lubrication: sea water or substitute ocean water ( $23^{\circ}\text{C} \pm 2^{\circ}\text{C}$ ), or mineral oil ( $80^{\circ}\text{C} \pm 2^{\circ}\text{C}$ ), or grease ( $80^{\circ}\text{C} \pm 2^{\circ}\text{C}$ ) according to the applicable lubrication type.

⑤ Surface roughness of test shaft: Ra shall not exceed  $0.5 \mu\text{m}$  for stainless steel and Ra shall not exceed  $0.8 \mu\text{m}$  for copper alloy.

⑥ Interface pressure : maximum nominal surface pressure  $\pm 10\%$ .

⑦ Duration of test: until the coefficient of friction and wear rate remains constant at least 192h. Wear of bushings shall be measured continuously or regularly. If regularly, wear to be measured by disassembling every 48 hours until a constant wear rate has been achieved (minimum of four points of measurements).

⑧ Parameters to be recorded:

- dimensions of test specimen

- wear vs. time

- coefficient of friction vs. time

- temperature of test specimen during test cycle

- deviation of load from the maximum nominal surface pressure

(3) The tests for rudder bearings may be carried out with reference to the requirements stated below.

① The diameter of rocker shaft is to be 100mm;

② The test specimen is to be part of the fixed bearing (see Fig. 4 for details) and to cover at least  $50^{\circ}$  circumferential range of the rocker shaft. The length of the bearing specimen is to be ~~1.2 times of the diameter of the rocker shaft (to be 80-120mm for shafts of 100mm in length)~~ and the diameter of the bearing is to be 1mm more than that of the rocker shaft or in accordance with the manufacturer's recommendations.

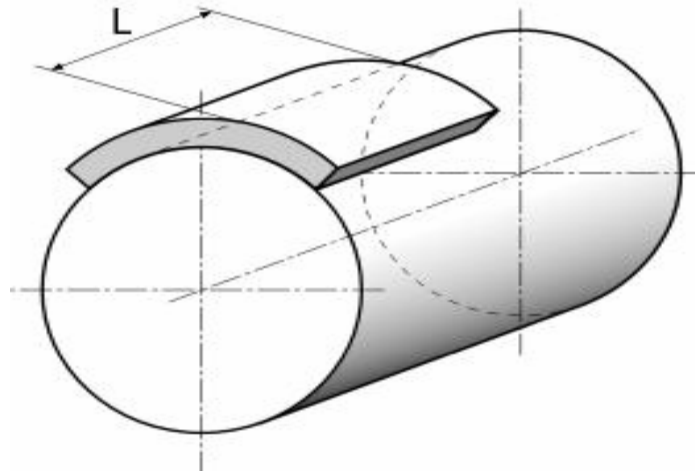

**Fig. 4 Test Specimen**

- ③ Artificial seawater is to be used for lubrication.
- ④ The swing amplitude of the rocker shaft is to be  $\pm 15^\circ$ .
- ⑤ The test is to be carried out at the applied surface pressure and double applied surface pressure respectively.
- ⑥ The test may be carried out in dry state or artificial seawater lubricated state.
- ⑦ The ambient temperature is to be  $20^\circ\text{C}$ .
- ⑧ The test velocity is to be  $3.5\text{mm/s}$ .
- ⑨ The rocker shaft is to work continuously at the applied surface pressure. Prior to the test, upon the consent of CCS and taking into account the limit of PV value of the material, for the materials having a surface pressure higher than that being applied for, the test may be suspended for no longer than 10S each time when the rocker shaft passes the bearing center line.
- ⑩ The duration of the test is to be such that a stable wear rate is achieved (at least 192 hours at  $3.5\text{mm/s}$ ) or 850 hours at maximum (not including the time consumed by dismantlement and stops).
- ⑪ The rocker shaft is to be made of stainless steel and have a maximum surface hardness of 220HV5. The surface roughness of the friction pairs is to be  $R_a=0.8\mu\text{m}$ .
- ⑫ The wear of the bearing or shaft is to be continuously or periodically measured. Where periodical measurement is adopted, the bearing or shaft is to be dismantled and measured once every 48 hours until a stable wear rate has been reached as demonstrated by four satisfactory measurements.
- ⑬ The relationship of wear loss to time and pressure, the relationship of wear loss to test cycle, the relationship of wear loss to travel distance and the relationship of friction factor (to be measured continuously or periodically to a stable wear rate at  $20^\circ\text{C}$ ) to time and pressure are to be demonstrated by charts.
- ⑭ To distinguish thermal expansion from the measured wear loss, thermocouples are to be used where necessary. Thermal expansion and expansion caused by immersion in water are to be taken into account when the wear data is determined.
- ⑮ For materials having an applied surface pressure not greater than  $5.5\text{N/mm}^2$ , dry friction and wear test is to be carried out at  $20^\circ\text{C}$  and  $80^\circ\text{C}$ , at the applied surface pressure and at double applied surface pressure, under dynamic and static conditions respectively. The measurement of friction coefficient during the test is to comply with the requirements of article (1).

- ⑩ For materials having an applied surface pressure greater than 5.5N/mm<sup>2</sup>, in addition to the test as required in ⑨, wet friction and wear test is to be carried out. The measurement of friction coefficient during the test is to comply with the requirements of article (1).

~~7.3.136.3.7 Other testing standards may also be accepted, provided that they are suitable for testing of the materials. Where the requirements for the result limits of the abovementioned tests are not available, the related test results are to comply with the manufacturer's specifications.~~

## **8.7 Unit/batch inspection**

8.7.1 Unit/batch inspection is to be carried out provided that the manufacturer has been approved by CCS.

8.7.2 Unit/batch inspection items

- (1) Test of compressive stress and compressive modulus ~~of elasticity~~ is to be in accordance with the requirements of ~~7.3.1~~, only required for non-elastomeric materials.
- (2) Hardness test is to be in accordance with the requirements of ~~7.3.86.3.3~~ and the test results are to comply with the manufacturer's specifications.
- (3) Tensile strength and elongation test is to be in accordance with the requirements of ~~7.3.26.3.2~~, only required for elastomeric materials.
- (4) Density test is to be in accordance with the requirements of ~~7.3.116.3.5~~ and the test results are to comply with the manufacturer's specifications.

## **9 Others**

The Type Approval Certificate shall contain the general information of products as product details, physical property of item 6.3.1 and 6.3.6 , maximum nominal surface pressure, and maximum operating temperature.

Products qualified through inspection are to be clearly identified with CCS signs.

Products or product packages are to be identified with the marks of the product name, manufacturer name, trademark, product code, date of manufacture, etc.