



Guideline No.: F-09(2024~~XX~~07)

F-09

FIRE MONITOR

Issued date: ~~XX~~Jun-~~XX~~01~~20~~,2024

© China Classification Society

Foreword:

China Classification Society (hereinafter referred to as CCS) Product Inspection and Testing Guideline (hereinafter referred to as this Guideline) contains the technical requirements, inspection and testing criteria related to classification and statutory survey of marine products to be applied for CCS approval/inspection.

This Guideline frees the users to adopt other test methods and requirements which are equivalent to or are stricter than this Guideline.

This Guideline is published and updated by CCS, and is released at <http://www.ccs.org.cn>. Your comments or suggestions are welcomed and may be sent to our email addressed mp@ccs.org.cn.

Historical version and release date: F09(201510) October 20, 2015

Main changes: ~~New Release~~

Due to the updated version of GB 19156 Fire Monitor, the definition of fire cannons has been modified; added requirements for corrosion-resistant materials for fire monitors; revised the testing requirements for water pressure sealing test and water pressure strength test of fire monitors; added testing requirements for high and low temperature performance tests and material salt spray corrosion tests; modify the performance parameters of fire water monitor, fire foam monitor and dual-use fire monitor; modified the illustrations of foam collector and foam receiver.

CONTENTS

1 Application.....	4
2 Normative references	4
3 Terms and definitions.....	4
4 Drawings and documents	4
5 Technical requirements	5
6 Materials and components.....	8
7 Type test.....	8
8 Unit/batch inspection	12

Fire Monitor

1 Application

1.1 The Guideline are applicable to the fixed deck foam systems specified in 10.8.1, Chapter II-2 of SOLAS and foam monitors required for helideck fire fighting systems specified in 18.5.3, Chapter II-2 of SOLAS.

1.2 This Guideline is applicable to the fire water monitors and foam monitors required for fire fighting ships specified in Chapter 1, [Part Eight](#) of CCS Rules for Classification of Sea-going Steel Ships.

2 Normative references

2.1 Regulations 10.8.1 and 18.5.3, Chapter II-2 of SOLAS 1974 and Amendments thereto

2.2 Chapter 14 of International Code for Fire Safety Systems

2.3 MSC.1/Circ.1431 Guidelines for Inspection of Foam Fire Extinguishing Equipment Used for Helideck Protection

2.4 Chapter 1, [Part Eight](#) of the Rules for Classification of Sea-going Steel Ships

2.5 GB19156- [2019](#) Fire Monitors

3 Terms and definitions

3.1 Fire monitor: A device for spraying extinguishing agent when the flow of water or foam mixture is greater than 16L/s or the average dry powder spraying rate is greater than 8kg/s during continuous spraying.

3.2 Foam/water dual use fire monitor: A fire monitor that uses the same channel to spray two different media (foam and water) at different times.

4 Drawings and documentations

4.1 For product approval, the following drawings and documentation to be submitted are to be submitted to CCS for product approval:

4.1.1 General assembly drawing of the product series;

4.1.2 Main properties and specifications table;

4.1.3 Summary table of material mechanical and chemical properties of main parts;

4.1.4 Technical specifications for acceptance of delivered products;

4.1.5 Type test plan.

4.2 For product approval, the following drawings and documentation to be submitted are to be submitted to CCS for review:

4.2.1 Instructions for use of product;

4.2.2 Instructions for maintenance.

5 **T**echnical requirements

5.1 The rated working pressure of fire water monitor, foam monitor and foam/water dual use monitor at various flow rate stages is to comply with the requirements of Table 1, Table 2 and Table 3 respectively. The rated working pressure of fire water monitor, foam monitor and foam/water dual use monitor is allowed to exceed the upper limit values given in Table 1~Table 3, but is not to exceed 1.6MPa (except for the circumstance involving special purposes).

5.2 The angles of pitching rotation of fire monitors: minimum depression angle is to be $\leq -30^\circ$ and the maximum depression angle is to be $\geq +60^\circ$.

5.3 The horizontal rotation angle of fire monitors is to be 360° when it is manually operated and $\geq 270^\circ$ when it is electrically operated.

5.4 Fire monitors should be made of corrosion-resistant materials such as copper or stainless steel with a corrosion resistance performance not lower than 1Cr18Ni9Ti. Those made of other materials should undergo anti-corrosion treatment to meet the anti-corrosion requirements of the corresponding operating environment and medium. After conducting salt spray corrosion tests according to Article 7.12, they should be able to operate normally without peeling, peeling, or visible pitting.

5.5 Appearance

5.5.1 The surfaces of forged parts are to be smooth, bright and free from defects affecting the strength and performance of the forged parts, such as crack, porosity, shrinkage cavity, blow hole, etc.

5.5.2 Welded seams are to be smooth and even and free from lack of penetration, burn through, beads and other defects detrimental to the strength and appearance quality.

5.5.3 The corrosion protective coating on the external surface of fire monitors is to be smooth, clean, even and free from defects affecting appearance quality, such as air voids, apparent flow marks, cracking, etc.

5.6 Maneuverability

5.6.1 The pitching rotation mechanism, horizontal rotation mechanism and various control levers (wheels) of fire monitors are to be flexible to operate and the transmission mechanism of fire monitors is to be safe and reliable.

5.6.2 The pitching and horizontal rotation mechanisms of fire monitors are to be provided with self-locking function or locking arrangements to prevent swaying or sliding when the fire monitors are spraying at the angle set as required.

5.6.3 For manual operation of horizontal pitch and rotation through a handwheel, the operating torque should not exceed 15N · m; For manual operation of horizontal pitch and rotation through the operating lever, the operating torque should not exceed 20N · m.

5.6.4 The operating torque of the fire monitor with flow and spray functions shall not be greater than 15N ·m during the conversion operation.

5.6.5 For the fire monitor with continuously adjustable spray angle, its continuously adjustable spray angle shall at least meet the requirements of 0 °~90 °adjustable, and can realize continuous conversion of spray angle.

5.7 A pressure gauge having a precision level not less than 2.5 grade is to be fitted at an appropriate location on the surface along the external diameter of the monitor base.

5.8 Special requirements

5.8.1 Foam monitor used in fixed deck foam system

5.8.1.1 Foam monitors are to be capable of spraying the foam onto the entire area of cargo oil tank deck and into any cargo oil tank whose deck has been damaged.

5.8.1.2 When the capacity of a foam system is designed, the effective range of foam monitors is to be defined to be 75% of the monitor's range under static wind conditions.

5.8.1.3 One foam monitor is to be provided respectively on both sides of each ship. The greater of the values listed below is to be taken as the design flow rate of each foam monitor:

- (1) Area of cargo oil tank deck $\times 0.3$ l/min, where the area of cargo oil tank deck means the ship's extreme breadth multiplied by the longitudinal total length of all cargo oil tank spaces; or
- (2) Area of the horizontal section of a single cargo oil tank having the largest area $\times 3$ l/min; or
- (3) The maximum protection area in front of the foam monitor $\times 3$ l/min; but not less than 1250l/min.

5.8.1.4 The differences between the actual expansion ratio and drainage time of the foam generated and sprayed by foam monitors and the parameters published by the manufacturer of the foam extinguishing agent are to be within $\pm 10\%$.

5.8.1.5 If the foam monitors have any motor-driven mechanism and are installed in hazardous areas where explosive gases are likely to be present, the driving motors are to comply with the electrical explosion protection requirements specified in 1.3.3, Chapter 1, [Part Four](#) of CCS Rules for Classification of Sea-going Steel Ships.

5.8.1.6 Valves are to be installed on the foam main and fire main (if the latter is an integral part of the deck foam system) in front of the foam monitor to provide effective isolation in the event of foam pipe damage.

5.8.2 Foam monitors on external fire fighting ships

5.8.2.1 Each external fire fighting ship is to be equipped with two foam monitors, with each foam monitor having a flow rate not less than 300m³/h, and the expansion ratio of foam is not to exceed 12;

5.8.2.2 The spray height of foam monitors is to be at least 50m above the sea surface;

5.8.2.3 Foam monitors are to be provided with, in addition to local manual control devices, remote control facilities. The remote control facilities of foam monitors and those of water monitors are to be arranged in the same space.

5.8.2.4 Design and bracket of foam monitors

- (1) Foam monitors are to be of robust construction;
- (2) The brackets of foam monitors are to have sufficient strength under varying working conditions.

5.8.3 Fire water monitors on external fire fighting ships

5.8.3.1 The minimum quantity and properties of water monitors are to comply with the requirements of Table [41.1.1.4 of Chapter 1 Part Eight of China Classification Society Rules for Classification of Sea-Going Steel Ships](#).

5.8.3.2 Arrangement of water monitors system

- (1) Water monitors are to be capable of adequately adjusting the angles in vertical and horizontal directions to ensure optimum point of fall of the water jets. The required operating range is to be free from obstacles obstructing the water jets;
- (2) Water monitors are to be installed on fixed and secure brackets capable of withstanding the applied forces under various operating conditions;
- (3) At least two water monitors are to be fitted with nozzles capable of spraying water jet or water mist as required.

5.8.3.3 In addition to local manual control devices, water monitors are to be provided with remote control facilities. The remote control facilities are to be installed at locations with means of protection and with good vision to allow for observation of water monitors and the points of fall reached by the water jets.

5.8.3.4 Design and bracket of water monitors:

- (1) Water monitors are to be of robust construction to sufficiently withstand the recoil force generated by spraying;
- (2) The bracket of water monitors is to have sufficient strength under varying working conditions.

5.8.4 Helideck foam monitors

5.8.4.1 The helideck is to be equipped with at least two fixed foam monitors;

5.8.4.2 Foam monitors are to be installed at such locations as to ensure that the distance from the foam monitors to the farthest edge of the protected area does not exceed 75% of the spray range of the foam monitors under static wind conditions;

5.8.4.3 The flow rate of each foam monitor is to reach 50% of the minimum flow rate required by the foam system and be not less than 500 l/min. The minimum flow rate required by the foam

system is equal to 6 l/min.m^2 helideck D-value.

5.8.4.4 Foam monitors are to be capable of withstanding surrounding environment temperature changes, general vibration, humidity, impact and corrosion encountered on open decks.

5.8.4.5 Foam monitors are to be manufactured with brass, bronze or stainless steel materials. The components other than gaskets are to be designed to withstand $925 \text{ }^\circ\text{C}$ high temperature;

5.8.4.6 Oscillating monitors, if used, are to be preset to spray water mist and be provided with adjusting mechanism for quick changeover from oscillating mode to manual operation mode;

5.8.4.7 When the maximum flow rate of foam monitors is not more than 1000 l/min, self-suction nozzles are to be used to suck foam extinguishing agent from the foam liquid branch. When the flow rate of foam monitors is more than 1000 l/min, non-self-suction nozzles are to be used.

6 Materials and components

6.1 The list of qualified suppliers of main raw materials should be provided to CCS for reference, and the list should at least list the materials and suppliers of the gun body and barrel.

6.2 When the main raw materials included in the qualified supplier list involve changes, should inform CCS.

7 Type test

7.1 Selection of typical test specimens

Fire monitors are usually to be designed into series by flow rate. Therefore, foam monitors, foam/water dual use monitors and water monitors of minimum, moderate and maximum flow rates are to be selected and type tested respectively.

~~7.2~~ Visual inspection. Appearance quality of fire monitors is to meet the requirements of 5.5.

~~7.3~~ Pitching rotation angle and horizontal rotation angle test. The pitching rotation angle and horizontal rotation angle of fire monitors are to be examined using angle gauge and the results are to meet the requirements of 5.2 and 5.3.

~~7.4~~ Fire monitor maneuverability test. The operating mechanism of fire monitors is to be examined at the maximum spray pressure and the results are to meet the requirements of 5.6.

~~7.5~~ Hydraulic seal test. Prior to hydraulic seal test, the pressure parts of fire monitors (except the-barrel-of-cannon of the foam monitor) are to be sealed and the fire monitors are to be filled with water and purged free of air. Then the pressure is slowly applied to 1.6 MPa or 1.1 times maximum working pressure (Take the larger value of both) and this test pressure is to be held for ~~5 min~~ 3 min. Various connections are to be free from leakage.

~~7.6~~ Hydraulic strength test. Prior to hydraulic seal test, the pressure parts of fire monitors (except the-barrel-of-cannon of the foam monitor) are to be sealed and the fire monitors are to be filled with water and purged free of air. Then the pressure is slowly applied to 2.4 MPa or 1.5 times

maximum working pressure (Take the larger value of both) and this test pressure is to be held for 5min. The body of the fire monitor is to be free from defects such as sweating, crack, permanent deformation, etc.

7.76 Measurement of spray angle. The spray angle may be measured by overlapping two sides of the angle gauge with the spray edges of water monitors respectively. The results are to meet the requirements of Clause 5.6.5 or manufactory's design.

7.87 Measurement of flow rate

7.87.1 Measurement of the flow rate of water monitors and foam monitors (water is to be used in replacement of foam solution)

7.87.1.1 An appropriate capacity of the metering tank is to be selected according to the flow rate of water monitors or foam monitors. Water pump is to be started to cause the water monitors or foam monitors to spray. After the rated spray pressure has been reached and become stable, the water monitors or foam monitors are to spray into the metering tank for 30s. Then the volume or mass of the water in the metering tank is measured and the flow rate of water monitors or foam monitors determined through calculation.

7.87.1.2 Direct measurement of flow rate using calibrated flow meter

7.87.1.3 The measurement is to be performed by the test method specified in 7.7.1.1 or 7.7.1.2 and the results are to meet the requirements of Table 1, Table 2 and Table 3. The flowmeter measuring method is to be used as the arbitration method.

7.98 Measurement of the spray range of water monitors and foam monitors

7.98.1 Test conditions. The spray range of water monitors and foam monitors is to be measured on an even ground. For the test, a pressure gauge having a precision level not less than 1.5/1.6 grade is to be fitted at the inlet of the monitor. The elevation angle of the water monitors or foam monitors is to be $+28^{\circ} \sim 32^{\circ}$. The vertical distance from the outlet of the water monitor or foam monitor to the ground surface is not to exceed 3m. The monitors are to spray downwind while the wind speed is to be less than 2m/s. The spray range is to be measured from the point of origin, i.e. the point of intersection between the plumb line of the water monitor or foam monitor outlet and the ground surface.

7.98.2 Test operation. The water pump is to be started and the water monitor or foam monitor is to be allowed to spray downwind. The spray range of the water monitor or foam monitor is to be the distance between the farthest point of the continuously falling agent and the point of origin, measured when the inlet pressure of the water monitor or foam monitor has reached the rated working pressure and become stable for not less than 10s.

7.98.3 The measured spray range of the ~~water monitor or foam~~ monitor is to meet the requirements of Table 1, Table 2 and Table 3.

7.109 Measurement of mixing ratio. The mixing ratio is measured with a refractometer by using the principle that foam solutions of varying concentrations have different refractive index. The details of the method are as follows:

7.109.1 Plot the calibration curve. Use drip tube to take the 6% foam solution to be used for the test and drip foam solution of 3 ml, 6 ml and 9 ml respectively into three 100ml measuring

cylinders. Add test water into each measuring cylinder to 100ml level to prepare foam solutions of 3%, 6% and 9% standard concentration. After the solutions are mixed well, take the readings of the refractometer scales and plot the refractometer scale-foam solution concentration calibration curve.

7.10.2 Plot the calibration curve. Use drip tube to take the 3% foam solution to be used for the test and drip foam solution of 1 ml, 3 ml and 5 ml respectively into three 100ml measuring cylinders. Add test water into each measuring cylinder to 100ml level to prepare foam solutions of 1%, 3% and 5% standard concentration. After the solutions are mixed well, take the readings of the refractometer scales and plot the refractometer scale-foam solution concentration calibration curve.

7.10.2-3 Use the drained liquid in the test described in 7.10 as the test specimen, take the readings of refractometer scale and check the mixing ratio of the test specimen on the calibration curve. The mixing ratio is to meet the requirements of Table 2 and Table 3.

7.110 Determination of the expansion ratio of foam and drainage time

7.110.1 Special test devices

7.110.1.1 The structure and main dimensions of foam collector are shown in Fig. 1. Foam collector is constructed of 2mm thick aluminum plate.

7.110.1.2 The structure and main dimensions of foam receiver are shown in Fig. 2. The foam receiver body is constructed of 0.5mm thick brass plate. The foam receiver has a capacity of 1600 ±20ml and a diameter of 6.4mm, with a transparent glass switch being installed in the center of the bottom.

7.110.2 Test procedure

7.110.2.1 Sampling

Firstly allow the foam monitor to spray into other directions, and after the rated working pressure has been reached and become stable, allow the foam monitor to spray into the foam collector. After the foam receiver is filled with foam, stop spraying and begin timing. Use a scraping sheet to scrape off the excessive foam on the top and wipe the external surface clean. At this stage the sampling is completed.

7.110.2.2 Determination of expansion ratio of foam

Measure the mass of the receiver filled with foam and calculate the expansion ratio of foam by formula (1):

$$N = \frac{V_e}{W'_e - W_e} d \quad (1)$$

Where, N ——expansion ratio of foam;

V_e ——capacity of foam receiver, in milliliter (mL);

W'_e ——total mass of the receiver filled with foam, in gram (g);

W_e —— mass of foam receiver, in gram (g);

d —— density of foam solution, 1.0g / mL.

7.110.2.3 Determination of 25% drainage time

Place the measuring cup on a weighing instrument (accurate to 1g) to measure its tare weight. Place the foam receiver containing test specimen on the support and open the bottom switch of the receiver to allow the drained liquid to flow into the measuring cup. Stop timing and record the 25% drainage time when the weight of the foam solution in the measuring cup is equal to W_f .

$$W_f = (W'_e - W_e) \times 25\% \quad (2)$$

Where, W_f —— 25% mass of the drained liquid, in gram (g);

W'_e —— total mass of the receiver filled with foam, in gram (g);

W_e —— mass of foam receiver, in gram (g).

7.110.2.4 Correction of the influence of test temperature

- (1) The temperature of water in the foam solution has significant influence on the expansion ratio of foam and drainage time. Therefore, such temperature is to be controlled within the range of 15 °C~25 °C during the test as far as practicable. If the test has to be carried out at a water temperature beyond this range, the following corrections are to be made for protein foam extinguishing agents:
- (2) Expansion ratio of foam—no correction is to be made when the temperature of foam solution is higher than 20 °C; when the temperature of foam solution is not greater than 20 °C, the expansion ratio of foam is to be increased by 0.1 with each temperature decrement of 1.7 °C.
- (3) Drainage time—when the temperature of foam solution is higher than 20 °C, the drainage time is to be increased by 0.1min with each temperature increment of 1.7 °C; and when the temperature of foam solution is not greater than 20 °C, the drainage time is to be decreased by 0.1min with each temperature decrement of 1.7 °C.

7.11.3 The measured expansion ratio of foam and 25% drainage time are to meet the requirements of Table 2 and Table 3.

7.12 High and low temperature performance test

7.12.1 Conduct the test according to GB/T 2423.2, place the fire monitor in a high-temperature box, and raise the temperature to 55 ± 2 °C at a heating rate of no more than 0.5 °C/min. Store under these conditions for 24 hours, and inspect after removal. The fire monitor should be able to work normally.

7.12.2 According to GB/T2423.1, the dry fire monitor should be placed in a low-temperature box and stored at -30 ± 2 °C for 24 hours. After removal, it should be checked and should be able to work normally.

7.13 Salt spray corrosion test of materials

7.13.1 Before the experiment, the surface of the monitor should be carefully cleaned without leaving any oil or dirt. Do not use abrasives or solvents during cleaning. The monitors should not come into contact with each other or with the walls of the test box.

7.13.2 The experimental period is 120 hours. During the experiment, salt solution should be prevented from directly impacting the surface of the fire monitor. After removing the test piece from the test box, it should be rinsed with clean water not exceeding 38 °C. After drying, the surface corrosion of the fire monitor and accessories should be checked. The test results meet the requirements of Clause 5.4

7.13.3 The test conditions for salt spray corrosion test should comply with the following regulations:

- a) The concentration of sodium chloride solution is 50g/L ± 1g/L;
- b) The pH value at 25 °C should be maintained within the range of 6.5 to 7.2;
- c) The spray rate is 1mL/h~2mL/h (the average spray rate measured 24 hours after the collector with an effective area of 80cm² is put into the test chamber);
- d) The temperature inside the test chamber should be maintained at 35 ± 5 °C;
- e) The spray shall not be interrupted during the test cycle. The test chamber can only be opened for a short time during inspection or other necessary operations, but the surface of the fire monitor shall not be touched.

8 Unit/batch inspection

For manufacturing plants that have obtained type approval B, at least 5% of each batch/specification should be inspected, and at least one fire monitor should witness the following test items:

- (1) Visual inspection (Clause 7.2);
- (2) Operational performance inspection (Clause 7.3 and 7.4);
- (3) Spray performance inspection (Clause 7.8 and 7.9), The fire monitor used for external fireboats can be loaded onto the ship for on-site testing;
- (4) Water pressure tightness performance test (Clause 7.5);
- (5) Water pressure strength performance test (Clause 7.6).

Water Monitor Performance Parameter

Table8(1)

Flow rate(L/s)	Rated working pressure(Mpa)	Spray range(m)	Permissible tolerance of flow rate
20	0.6	≥50	10%
25		≥55	
30	0.8	≥60	
40		≥65	
50	1	≥70	
60	0.8	≥75	
70		≥80	
80	1	≥85	
100		≥90	
120	1.2	≥95	
150	1	≥100	
180		≥105	
200	1.2	≥110	
250		≥115	
≥300	1.4	≥120	

FoamMonitor Performance Parameters

Table 8(2)

Foam solution flow rate (L/s)	Rated working pressure (MPa)	Spray range (m)	Permissible tolerance of flow rate	Expansion ratio(20 °C)	25% drainage time (s, 20 °C)	Foam solution flow rate (l/s)
24	0.6	≥42	10%	≥6	≥150	6% ~7% or 3% ~3.9% or manufacturer's published value
32		≥48				
40	1.0	≥55				
48		≥60				
64	0.8	≥70				
70		≥75				
80	1.0	≥80				
100	1.2	≥85				
120		≥90				
150	1.0	≥95				
180		≥100				
200	1.2	≥105				
>200	1.4	≥105				

The allowable range of manufacturer's published values should be:
 Mixing ratio rated value ≤ manufacturer's published values ≤ the smaller of (mixing ratio rated value × 130%) and (mixing ratio rated value + 1%)

Dual Purpose Fire Monitor Performance Parameters

Table 8(3)

Foam solution flow rate (L/s)	Rated working pressure (MPa)	Spray range (m)		Permissible tolerance of flow rate	Expansion ratio(20 °C)	25% drainage time (s, 20 °C)	Foam solution flow rate (l/s)
		Foam	Water				
24	0.6 0.8 1.0	≥42	≥55	10%	≥6	≥150	6%~7% or 3%~3.9% or manufacturer's publ
32		≥48	≥60				
40		≥55	≥65				
48		≥60	≥70				
64	0.8 1.0 1.2	≥70	≥75				
70		≥75	≥80				
80		≥80	≥85				
100		≥85	≥90				
120	1.0 1.2 1.4	≥90	≥95				
150		≥95	≥100				
180		≥100	≥105				
200		≥105	≥110				
>200		≥105	≥110				

The allowable range of manufacturer's published values should be:
 Mixing ratio rated value ≤ manufacturer's published values ≤ the smaller of (mixing ratio rated value × 130%) and (mixing ratio rated value + 1%)

单位为毫米

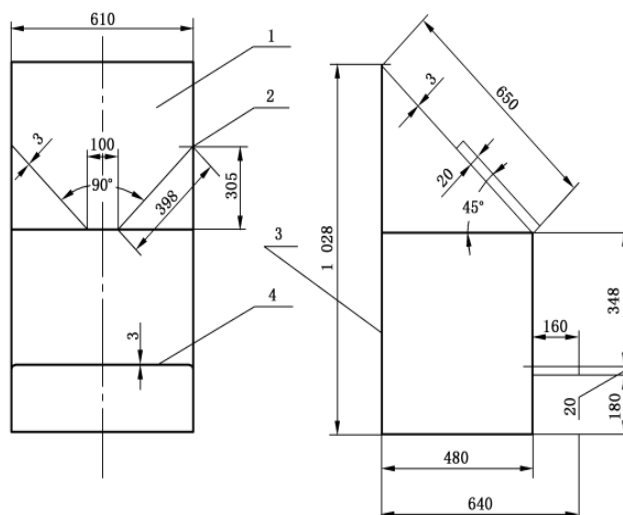

1. Foam collection board 2. Foam baffle 3. Support 4. Liquid analyzer

Fig. 8(1) Foam Collector

单位为毫米

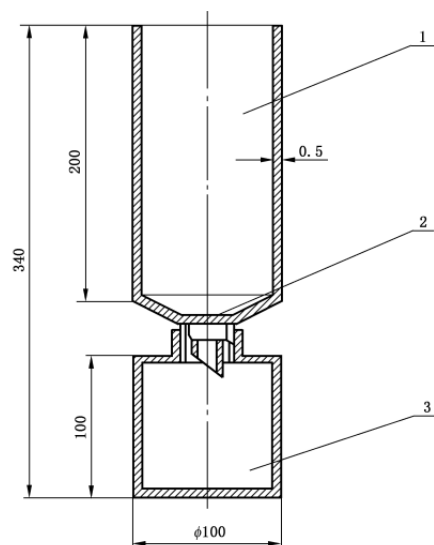

1. Foam receiver 2. Sieve 3. Liquid receiving tank

Fig. 8(2) Foam Receiver