

Guideline No.P-06 (202211)



P-06

HIGH-VELOCITY VENT VALVE

Issued date: November 15, 2022

© China Classification Society

Foreword

China Classification Society (hereinafter referred to as CCS) Product Inspection and Testing Guideline (hereinafter referred to as this Guideline) contains the technical requirements, inspection and testing criteria related to classification and statutory survey of marine products to be applied for CCS approval/inspection.

This Guideline frees the users to adopt other test methods and requirements which are equivalent to or are stricter than this Guideline.

This Guideline is published and updated by CCS, and is released at <http://www.ccs.org.cn>. Your comments or suggestions are welcomed and may be sent to our email addressed mp@ccs.org.cn.

Historical versions and release date: P-06 (201510) October 20, 2015

P-06 (201705) May 9, 2017

Main changes:

- 1) Correction of the full text and revision of version number of the new version of ISO15364;
- 2) 2.1. (5)Deleting its item;
- 3) 4.1 ④ l/min is changed to m³ /h. Adding "or 75%" after "80%";
- 4) 9.1 Deleting this description;
- 5) 9.3 (4) ① According to the requirements of ISO 15364, the dimension inspection test is supplemented, the name of the inspection item is modified to "appearance and dimension inspection", and the inspection content is added with "main parts dimensions, dimensions and gaps of affecting fire resistance";
- 6) 9.5 (5) Adding "If the device adopts ISO15364:2021 standard, the flashback test and endurance burning test shall also meet the requirements of ISO16852:2016.";
- 7) 9.5 (6) ③ Adding "If the high-speed vent valve refers to ISO15364:2021, air deflagration test, low flow flame transmission test, flame transmission test by opening and closing, deflagration test and endurance burning test shall also be carried out, and the test device and technical requirements shall meet the requirements of ISO16852:2016.";
- 8) 9.5 (7) Text revised, "detonation" changed to "deflagration" and adding "If the flame arrester

refers to ISO15364:2021, the deflagration test and endurance burning test shall also be carried out, and the test device and technical requirements shall meet the requirements of ISO16852:2016."

9) Deleting the content that "In this test, a complete device shall be exposed to a temperature of -10°C for a period of 24h if ISO15364:2016 is referred to;" in item 9.5 (8);

10) 9.5 (12) Deleting the detail content of as follows:

Undamped oscillation tests should be carried out as follows if ISO15364:2016 is referred to:

- ① Each model and size of high velocity valves shall be tested for undamped oscillation;
- ② Change of setting by replacing components(e.g.weight,disc,etc.) requires undamped oscillation test of each setting;
- ③ Each nozzle of a dual nozzle valve shall be tested for undamped oscillation;

11) Deleting "According to Chapter 3, Part One of CCS Rules for Classification of Sea-going Steel Ships, high-velocity vent valves and other devices, after approval by CCS, are to go through the unit/batch inspection and issued with a certificate:" and adding "the unit/batch inspection after approved"

CONTENTS

1 Application.....	4
2 Normative references	5
3 Terms and definitions.....	6
4 Drawings and documents	7
5 Materials and components.....	11
6 Welding procedures qualification	11
7 Design and technical requirements	11
8 Selection of typical samples.....	18
9 Type test.....	18
10 Unit/batch inspection	29

HIGH-VELOCITY VENT VALVE

1 Application

1.1 This Guideline contains the requirements for design, test, installation and maintenance of high-velocity vent valves, pressure/vacuum valves, vent caps and other devices (hereinafter referred to as the “devices”) which prevent the passage of flame into liquid cargo tanks. It applies to liquid cargo tank venting systems to be installed on the oil tankers and combination carriers passing the classification survey by CCS and carrying crude oil and petroleum products with flash point $\leq 60^{\circ}\text{C}$ (closed cup) and Reid vapor pressure (RVP) $<$ atmospheric pressure as well as other cargoes which would pose similar fire hazards; these venting systems are to provide protection against any gas/vapor pressure/vacuum exceeding the design parameter of the system/tank.

1.2 Oil tankers and combination carriers equipped with inert gas systems conforming to Chapter II-2 of SOLAS are to have devices meeting this Guideline but not required to satisfy the test requirements as described in Articles 9.4 (5) ③ and 9.4 (6) ③ (b) of this Guideline. These devices are to be installed at openings only unless they are compliant with the test requirements given in Article 9.4 (7) of this Guideline.

1.3 This Guideline applies to devices protecting liquid cargo tanks loaded with crude oil, petroleum products and inflammable chemicals. Where chemicals are contained, test media mentioned in Article 9 of this Guideline may be used for cargoes with maximum experimental safe gap (MESG) (refer to IEC60079-1A) ≥ 0.9 mm, whereas devices for chemical tankers which intended to carry chemicals with MESG < 0.9 mm are to be tested with the following media based on the equipment classification (explosion-proof grade) as set forth in Column I, Chapter 17 of IBC Code:

- (1) Classification (explosion-proof grade) II B - ethylene (MESG = 0.65 mm)
- (2) Classification (explosion-proof grade) II C – hydrogen (MESG = 0.28 mm)

Devices not covered in Column I, Chapter 17 of IBC Code are to be tested and verified according to the requirements of Classification (explosion-proof grade) II B.

The test gas concentration is to be selected according to IEC60079-1-1.

1.4 High-velocity vent valves, pressure/vacuum valves and other devices are to be tested and installed in accordance with this Guideline.

1.5 High-velocity vent valves, pressure/vacuum valves and other devices are provided to protect:

- (1) The openings designed for relief of pressure or vacuum due to temperature change;
- (2) The openings designed for relief of pressure or vacuum produced during cargo loading and ballasting;
- (3) The openings designed for degassing.

1.6 High-velocity vent valves, pressure/vacuum valves and other devices are to be designed such that bypassing or blocking of openings could be prevented unless tests have been carried out at the bypassing or blocking position according to Article 9 of this Guideline.

1.7 Since data is not available for establishing technical requirements for high-velocity vent valves, pressure/vacuum valves, etc., such ignition sources as electric sparks are not considered herein. Before the thunderstorm, cargo handling, tank washing and ballast operations are to be stopped.

1.8 This Guideline does not consider the possibility that flames enter a liquid cargo tank into another one through a common venting system.

1.9 Any devices required on oil tankers without inert gas systems to protect the outlet of the degassing system are to be compliant with this Guideline except for test requirements specified in Articles 9.4 (5) ③ and 9.4 (6) ③ (b).

1.10 Some tests described in Article 9 of this Guideline may pose hazard potential, however safety requirements are not provided herein and therefore are to be within the full responsibility of the test organization.

1.11 The latest requirements of the Administration of the flag State are to be complied with.

Note 1: Devices for ships with EU flag may be required to comply with EN ISO16852-2010 Flame arresters - Performance requirements, test methods and limits for use;

Note 2: Devices to be certified under EU Marine Equipment Directive (MED) are to be compliant with ISO15364-2007(or ISO15364-2016)Ships and marine technology - Pressure/vacuum valves for cargo tank.

1.12 For flame arresters of other types and purposes, reference may also be made to the applicable part of this Guideline.

2 Normative references

2.1 The following standards are the bases for approval and inspection in this Guideline:

- (1) International Convention for Safety of Life At Sea (1974) and amendment (Hereinafter referred to as "SOLAS")
- (2) IMO MSC/Circ.1009 Amendments to Revised Standards for the Design, Testing and Locating of Devices to Prevent the Passage of Flame into Cargo Tanks in Tankers (MSC/Circ.677)
- (3) IMO MSC/Circ.677 Revised Standards for the Design, Testing and Locating of Devices to Prevent the Passage of Flame into Cargo Tanks in Tankers
- (4) ISO15364-2000 Ships and Marine Technology – Pressure/Vacuum Valves for Cargo Tank(ISO15364-2007/2016/2021 also can be chosen, but it should be comply with the relevant requirements of it)
- (5) CCS Rules for Classification of Sea-Going Steel Ships
- (6) CCS Rules for the Construction of the Inland Waterways Steel Ships
- (7) CCS Rules for Construction and Equipment of Ships Carrying Dangerous Liquid Chemicals in Bulk

(8) CCS Rules for Construction and Equipment of Inland Ships Carrying Dangerous Chemicals in Bulk

(9) IMO MSC.1/Circ.1324 Amendments to Revised Standards for the Design, Testing and Locating of Devices to Prevent the Passage of Flame into Cargo Tanks in Tankers (MSC/Circ.677 as amended by MSC/Circ.1009)

2.2 The above bases for approval and inspection contain provisions which, through reference in this Guideline, constitute provisions of this Guideline. For the dated references, all the subsequent amendment lists (excluding the content of corrigendum) or revisions do not apply to this Guideline; therefore, the latest editions of these documents are to be complied with during the product design, manufacturing and inspection. For the undated references, the latest editions apply to this Guideline.

3 Terms and definitions

3.1 For the purpose of this Guideline, the terms and definitions given in SOLAS and CCS Rules for Classification of Sea-going Steel Ships apply.

3.2 The following definitions are added in this Guideline:

(1) Flame arrester

A device conforming to the specified performance standard and preventing the passage of flame, in which the arresting element functions to put out the flame.

(2) Flame screen

A device conforming to the specified performance standard and preventing the passage of free flame by using a wire mesh.

(3) Flame speed

The speed at which the flame spreads along pipelines or other systems.

(4) Flashback

Propagation of the flame through devices.

(5) High-velocity vent

A device intended to prevent the passage of flame and composed of a mechanic valve which can adjust the airflow opening based on the inlet pressure to ensure jet velocity ≥ 30 m/s (98 ft/s) so as to prevent the passage of flame.

(6) Pressure/vacuum valve

A device intended to maintain the pressure and vacuum of a closed container within the setting range, which is designed and tested according to this Guideline such that the passage of flame is prevented.

(7) Passive flame stopper

A device conforming to the specified performance standard and used for preventing the passage of free flame into the device, represented by the flame screen or flame arrester.

(8) Standard air

Dry air with temperature of 21°C (70°F) and pressure of 1,013.25 hPa (29.92 in mercury).

Note: It is actually equivalent to the air with density of 1.2 kg/m³ (0.075 lb/ft³). Dry air is to have specific heat of 1004.8 J/ (kg004) [0.24 btu/ (1bu°F)].

(9) (MESG), maximum experimental safe gap

The maximum connection gap between two components in the inner chamber of the test equipment, with the internal gas mixture ignited under the specified conditions, which is a characteristic of various gas mixtures, prevents external gas mixture being ignited through a 25-mm-long gap and may be used for all concentrations of the tested gas or vapor in the air. (Refer to IEC60079-1-1)

(10) Deflagration

Explosion which spreads at subsonic speed.

(11) Detonation

Explosion which spreads at supersonic speed and is characterized by shock wave.

(12) Pressure setting

The pressure under which the valve disc switches from closing to full opening rapidly, unless otherwise expressly stated or instructed.

(13) Rated flow

The standard air flow under 0.021 MPa for pressure valves or -0.007 MPa for vacuum valves, unless otherwise expressly stated or instructed.

(14) Dual nozzle valve

Pressure relief valve that features two high velocity vents with different opening settings integrated into one valve.

4 Drawings and documents

4.1 In the first application for type approval and plan examination of high-velocity vent valves and other devices, applicants are to provide CCS with the following plans and technical documents conforming to the design requirements of this Guideline for approval:

(1) Product performance specification table (or contained in the general assembly plan) generally including:

- ① Pressure valve (P) pressure setting (MPa);

- ② Vacuum valve (V) pressure setting (MPa);
- ③ Nominal diameter (DN);
- ④ Rated flow (m³/h) of pressure/vacuum valve, vent cap, etc., generally including the maximum rated pressure (MRP), minimum design discharge throttling velocity, as well as the maximum released gas rate for 80% or 75% normal opening pressure setting of the valve;
- ⑤ Product model;
- ⑥ Intended use and applicable medium;
- ⑦ Maximum heating temperature and heating medium (if any) of the heating device.

(2) General assembly plan which is generally to be indicated clearly:

- ① Interrelation between parts such as the housing, valve disc, valve seat, seals, flame screen, drain valve, valve core jacking mechanism and counterweight, fairing;
- ② Materials of main parts such as the housing, valve disc, valve seat and stem, shaft sleeve, seals, flame screen, fairing, counterweight;
- ③ Technical requirements for manufacturing, installation and inspection;
- ④ Main technical parameters;
- ⑤ Overall and mounting dimensions.

(3) Plans of the following main parts:

Housing, valve disc, seat, stem/shaft, seals (e.g. self-made component), flame screen assembly, fairing, etc.

(4) Production operation and maintenance instructions (operation manual) generally including the followings and meeting Article 7.8 of this Guideline:

- ① Specifications and standards followed in the product design, and the scope of application;
- ② Main technical parameters such as the allowable ice layer thickness and combination of materials;
- ③ Working principle (attached with related schematic diagram);
- ④ Installation instructions;
- ⑤ Operation instructions;
- ⑥ Maintenance requirements;

- ⑦ Necessary test report;
- ⑧ Fluidity test data;
- ⑨ Work's certificate;
- ⑩ Necessary safety warning;
- ⑪ Fault emergency treatment.

(5) Type test/inspection program which is to be clearly indicated:

- ① Test items and acceptable criterion;
- ② Test method;
- ③ Requirements for testing equipment and instruments;
- ④ Requirements for test environmental conditions;
- ⑤ Requirements for test gas;
- ⑥ Requirements for test safety.

(6) List of physicochemical (standard) properties of materials for main parts (e.g. housing, valve disc, seat, stem/shaft, shaft sleeve, seals, flame screen, fairing and other non-standard or non-GB-specified material);

(7) Main process documents (when applicable);

(8) Manufacturer's information:

- ① Factory profile: Name, address, production history, capacity, technicians and inspectors, main products, affiliation, trademark, etc;
- ② Details of the product to be approved;
- ③ Main production equipment;
- ④ Main testing equipment;
- ⑤ A brief description on production technology of the product to be approved;
- ⑥ Quality management document;
- ⑦ Registration certificate;
- ⑧ Qualification certificate and/or production license;
- ⑨ Sample of product quality certificate;

- ⑩ Quality control plan (where applicable).

4.2 The above information about the manufacturer and manufacturing processes (casting, welding, heat treatment, testing) (if applicable) are to be directly submitted to the execution unit of CCS that is responsible for type approval within the jurisdiction of the manufacturer.

5 Materials and components

5.1 Composition of high-velocity vent valve, pressure/vacuum valve, vent cap:

- (1) Pressure valve: housing, disc, counterweight or similar components (fitted as required), seat, stem/shaft, shaft sleeve, seals, manual jacking device, fairing, discharge valve;
- (2) Vacuum valve: housing, disc, counterweight (fitted as required), seat, pushing handle and stem/shaft, flame screen, seals;
- (3) Vent cap (fitted as required): valve cap, flame screen, seals;
- (4) Auxiliary device (fitted as required): devices for heating and deicing, melting and crystallizing, and washing.

5.2 The following purchased parts (if any) are to have a product quality certificate, and are to be compliant with related rules and standards accredited by CCS and sufficient for their intended purposes:

- (1) Materials for housing, valve core and seat;
- (2) Information about the flame screen to determine the material, wire diameter, mesh number, number of layers, etc.

6 Welding procedures qualification

6.1 Welding procedures qualification is to be compliant with the applicable requirements of Chapter 3, Part One of CCS Rules for Materials and Welding.

7 Design and technical requirements

7.1 Principle

- (1) High-velocity vent valves, pressure/vacuum valves and other devices are required to allow the vapor, air or inert gas mixture to be fully released under the pressure setting.
- (2) High-velocity vent valves and pressure/vacuum valves are to be rated for pressure setting greater than 0.007 MPa ~ 0.021 MPa (positive pressure) and less than 0.0035 MPa ~ 0.007 MPa (negative pressure), and are to ensure that valve disc will not bounce under positive pressure < 0.007 MPa and vacuum < 0.0035 MPa. Pressure valves to be used in liquid cargo tanks carrying poisonous substances are to have the minimum pressure setting of 0.02 MPa.
- (3) According to the use and mounting position, high-velocity vent valves and pressure/vacuum valves are to be capable of preventing propagation of the following flames cause by ignition of gases for any reason:

- ① Moving flame and/or
 - ② Stable flame of premixed mixture.
- (4) Ignition of flammable gas at the outlet may result in:
- ① For low speed flow:
 - (a) Flashback; or
 - (b) Stable combustion at the outlet like the combustor.
 - ② For high speed flow:
 - (a) Combustion at a height above the outlet; or
 - (b) Blow off.
- (5) To prevent the passage of flame into liquid cargo tanks, high-velocity vent valves and pressure/vacuum valves must provide one or more of the following functions:
- ① allow the passage but not flashback of gases, and prevent gases on the protected side from being ignited when these devices are heated within the specified time;
 - ② maintain the jet velocity above the flame speed, and prevent gases on the protected side from being ignited when these devices, regardless of the geometry, are heated within the specified time; and
 - ③ prevent the passage of flame when vacuum is produced in the liquid cargo tank.
- (6) An vent outlet used for liquid cargo handling and ballasting is to:
- ① ensure free passage of vapor mixture; or
 - ② ensure the discharge throttling velocity of vapor mixture ≥ 30 m/s.

7.2 Machine design standard

- (1) High-velocity vent valves and pressure/vacuum valves are to be designed such that internal elements are easy to remove for replacement, cleaning or repair.
- (2) Where these valves are designed such that internal parts may be inspected, cleaned, repaired or replaced without removing them from the system, the design is required to not allow any error during reassembly after removal, inspection, cleaning or repair of these valves.
- (3) The valve body is to have all junctions of planes finished and provide adequate metal-to-metal contact.
- (4) The flame arrester element is to be installed in such a way that flames could not pass through the gap between the element and the body.

- (5) High-velocity vent valves and pressure/vacuum valves are to effectively discharge moisture without impairing its efficiency of preventing the flame.
- (6) Tube end devices are to provide gas jets straight up at all flow velocities preset by the manufacturer.
- (7) All fasteners related to the action of valves are to be prevented from looseness. The pressure setting and regulating device is to be permanently fixed with locking steel wire, retaining nut or other appropriate means, to prevent setting errors due to operation, installation or vibration of valves.
- (8) Provision is to be made for easy inspection of valve opening state without the need for keeping it open.
- (9) Where high-velocity vent valves and pressure/vacuum valves function to stop the flame without provision of an arresting element, their seats must have a contact surface ≥ 5 mm in width.
- (10) When tested according to Article 9.4 (7) of this Guideline, tandem arrangements (flame arrester for pipe) are to withstand internal pressure caused by detonation without damage or permanent deformation.
- (11) The flame arrester element is to be designed such that manufacturing quality meets the type test characteristic as specified in this Guideline.
- (12) Venting arrangements are to be able to discharge the internal condensed liquid to the liquid cargo tank under all the normal heeling and trimming conditions of the ship. In general, the internal elements, passages and inner walls are to be inclined for discharge. If provision of self-discharge pipeline is impossible, a permanent device is to be used; where it is necessary to drain the venting system on any pressure/vacuum valve, a cover-sealing or plug-sealing discharge cock is to be provided to discharge liquids in the vent pipeline to the liquid cargo tank.
- (13) The design of high-velocity vent valves and pressure/vacuum valves is to allow the condensed vapor to be discharged without lowering their efficiency, and also to prevent standing water and thereby blockage due to freezing.

Where the design does not allow the condensate to be fully discharged through the junction of the valve and the liquid cargo tank, an at least 13-mm discharge outlet with a plug (nominal pipe size 1/2 in (NPS1/2)) is to be provided on the atmospheric vent side. The discharge outlet is to not allow the escape of vapors, unless appropriate means is adopted to prevent the passage of flame and suit to all the flow velocities and directions.

- (14) For applications in cargo tanks for inland waterways ships carrying chemicals in bulk with flash point $\leq 60^{\circ}\text{C}$ (closed-cup test), high-velocity vent valves and pressure/vacuum valves are to be equipped with indicators showing normal operation.
- (15) At the main pressure zone with reverse flow on the main valve seat, the valve body is to be airtight to prevent escape of vapors.
- (16) For applications in chemical tankers, high-velocity vent valves and pressure/vacuum valves

are to be designed such that ingress of water is prevented in the liquid cargo tank.

7.3 Materials

- (1) At the time of order, the Purchaser is to clearly indicate the requirements on materials of related parts and components, or select materials for main parts according to the BOQ provided by the manufacturer and ensure that the following Articles 7.3 (2), 7.3(3) and 7.3 (5) are complied with.
- (2) High-velocity vent valves and pressure/vacuum valves are to have their housings and bodies compliant with the similar standards for pipes connected to them in terms of the strength (including elongation), heat resistance and corrosion resistance. Their housings are generally to have an at least 6-mm-thick wall (corrosion allowance may be deducted depending on the medium for stainless steel housings).
- (3) The valve body and other components or screwed fittings used for pressure maintaining are to be of the materials which are sufficient for their intended purposes and listed in the recognized national or international standards.
 - ① The housing, valve disc, shaft, seat, spring, gasket, sealing device, passive flame stopper (if included in design) and all the other integral components including those with anticorrosion coatings are to be of materials against corrosion by seawater and the liquids and vapors in the protected tank.
 - ② The use of springs coated with corrosion-resistant materials is prohibited.
- (4) Non-metallic materials are not allowed for structural parts maintaining the pressure of the valves, other than gaskets and sealing devices.
 - ① The use of flexible sealing device is prohibited unless the sealing device of the valve is partially or completely damaged or burned out but remains effective in preventing the passage of flame.
 - ② A non-metallic gasket is to be of incombustible materials sufficient for their intended purposes.
 - ③ The use of materials containing asbestos is prohibited.
- (5) The housing, element and gasket are to be of materials able to withstand the high pressure and high temperature which may be experienced during the fire-proof test under normal conditions and requirements.
- (6) Materials for all components which are not covered above are to be sufficient for their intended purposes.
- (7) Material selection is to take into account the possibility of electrochemical corrosion.
- (8) Stainless steel materials, when used in main parts of the valve, are to be given solution treatment.

7.4 Performance standard

- (1) High-velocity vent valves and pressure/vacuum valves are to be tested according to Article 9 of this Guideline and compliant with the applicable test requirements as set forth in Articles 9.4 (5) through 9.4 (7).
- (2) High-velocity vent valves and pressure/vacuum valves are to be properly tested and verified for such performance characteristics as flow velocity under positive and negative pressures, action sensitivity, flow resistance and flow velocity. The flame screen is to be included in the venting capability test, except for high-velocity vent valves with gas discharge rate > 30 m/s.
- (3) Devices are to be designed and constructed such that the pollution impact is minimized under normal operation conditions, and internal residues due to vapor condensation and affecting normal operation could be detected. The manufacturer's operation manual is to indicate how to determine the time point and method for cleaning in details (see Article 7.8). A heating device may be provided for some cargoes prone to crystallize.
- (4) These valves are to be designed for all the expected ranges of environmental temperature, and freezing condition (e.g. freezing by cargo vapors or blockage due to icing in bad weather); and the operation manual is required to indicate the allowable thickness of ice cover if any. Where a heating equipment is provided to make the temperature of device surface reach above 85°C, a test is to be carried out at the maximum working temperature.
- (5) A high-velocity vent valve with the minimum flow velocity as the reference is to be able to open by fast increasing the velocity up to 30 m/s, and maintain at least 30 m/s jet velocity at all flows until it fully closes under the above minimum flow velocity even when the airflow is obstructed.
- (6) For high-velocity venting, the possibility of damage and/or failure due to unexpected harmful hammering is to be considered and eliminated.

Note: Hammering is rapid opening/closing over the full stroke, which may not be anticipated by the manufacturer during normal operation.
- (7) The valve body, parts and sealing gasket are to be of materials able to withstand the maximum and the minimum pressures and temperatures which may be experienced under normal operation conditions as well as the hydrostatic test as specified in Article 9.4 (2).

7.5 Flame screen

- (1) A flame screen is to be:
 - ① designed such that it would not be incorrectly inserted in the opening;
 - ② securely fixed in the opening to prevent the flame bypassing;
 - ③ compliant with this Guideline. A flame screen installed in the vacuum valve inlet not allowing escape of vapors is not necessarily to be compliant with the test requirements of Article 9.4 (5) ③; and
 - ④ prevented from mechanical damage.

7.6 Specification, mounting position and installation of the device

- (1) To determine the valve size and avoid unwanted pressure or vacuum in the liquid cargo tank during cargo handling, pressure loss calculation is to be made by the ship design and type selection party, with consideration of the following parameters:
 - ① Loading/unloading speed;
 - ② Gas precipitation;
 - ③ Pressure loss after passage through the device (considering drag coefficient);
 - ④ Pressure loss in the vent piping;
 - ⑤ Pressure setting where high-velocity vent valve is used;
 - ⑥ Density of saturated vapor-air mixture; and
 - ⑦ 70% rated performance to be considered in the calculation of pressure drop for installation to compensate for possible contamination of the flame arrester.
- (2) Devices are to be installed at an outlet open to the atmosphere unless tandem arrangements have proven acceptable through tests and obtained an approval. No tandem arrangement is allowed at an outlet open to the atmosphere unless it has proven acceptable through tests and obtained an approval.
- (3) Pipe end devices for inerting the openings of liquid cargo tanks are not necessarily to be subject to the fire test according to Article 9.4(5) ③.
- (4) Such accessories as the vent cap, weather shield and air deflector, if any, on the tube end device are to be installed and taken together to the test as described in Article 9 of this Guideline.
- (5) Like the tandem arrangements open to the atmosphere, a detonation flame arrester is to be arranged with enough distance to the pipeline open end, to eliminate the possibility that any stable flame rests on the flame arrester.
- (6) Where venting to the atmosphere is impossible through a tube end device as described in Article 7.6 (4) or through a detonation flame arrester in Article 7.6 (5), tandem arrangements (including all pipes, T-joints, elbows, vent caps, weather shields which may be installed between the device and the atmosphere) must be tested as specified. This includes the flashback test as described in Article 9.4 (5) ②; if the installation is provided that stable flame may stay on the device, fire test as described in Article 9.4 (5) ③ is also to be included.

7.7 Other requirements

- (1) It is necessary to check whether each valve is easily openable and would not remain open with the manual method provided in the operation instructions from the manufacturer. The design is to ensure that valves would not have residues due to corrosion or become

inoperable due to freezing during maintenance as required by the manufacturer (also refer to Appendix C of ISO15364).

- (2) During maintenance according to the manufacturer's instructions, due consideration is to be given to the fact that condensate may form through the valve during loading, therefore, the valve disc is to be furnished with an appropriate guiding device to prevent seizure and ensure appropriate self-closing function of the valve seat.

The valve disc is to be able to close normally on the seat through the metal-to-metal contact. The use of an elastic seal in the valve seat is allowed where the design requires a valve disc which would still close against the valve seat in the event that seal is damaged, destroyed or removed from the disc.

The valve disc may be solid or hollow to add the counterweight material so as to adjust the opening pressure. Where a hollow valve disc is used, a bolt-on watertight cover is to be considered to wrap up the counterweight material. No person other than the manufacturer is allowed to change the pressure setting without permission of the Administration or CCS. A mark indicating the disc position is to be provided on the external surface of the valve, which is generally to be clearly visible from below and any side of the valve on the deck. Where the pressure setting is changed, the mark as specified in Article 7.9 is to be updated accordingly.

- (3) A non-metallic diaphragm may be used in the valve except in cases where a fault occurs and makes vapors in the tank freely flow into the atmosphere, or the tank pressure or vacuum increases when the valve normally opens.
- (4) Where a structural part for pressure maintaining is of welding structure, design details of welded seam, welding and NDT are to be compliant with the applicable requirements of national or international standards. Welded seams are to be complete and strong enough to ensure the consistency of the quality; all welders and the welding process are to be approved by CCS and compliant with the recognized national or international standard.
- (5) The instruction manual mentioned in Article 7.8 below and the permanent mark in Article 7.9 are to be provided in both Chinese and English, or may be in English only if the user is a non-Chinese ship owner.

7.8 Manufacturer's instruction manual

- (1) The manufacturer is to ensure that each device is accompanied by an instruction manual which is to include all items as set forth in Articles 7.8 (2) ~ 7.8 (9), as well as the requirements of ISO15364:2007, ISO15364:2016, ISO15364:2016 and/or EN ISO16852-2010 if any.
- (2) Installation instructions.
- (3) Operation instructions. If a flame screen or high velocity vent is arranged, the minimum MESG and explosion-proof grade are to be included, together with the mandatory limits for use with respect to the device safety performance and mandatory requirements for correct installation.
- (4) Maintenance requirements including the maintenance data of each anticorrosion system.

- ① Instructions on how to determine the time point and method for cleaning the device.

Where the manufacturer allows overhaul to be done by the user, it is required to provide necessary process procedure, instructions and charts to ensure that the device is restored to its original pressure setting and flow.

- ② Instructions on the number of cleaning required for removal of condensed vapor. The number of removals of internal residues depends on the cargoes contained.
 - ③ A clear description on the method for pressure setting, including the assembly and disassembly, numbering method, order information and plans for correct assembly of parts.
 - ④ Instructions on the need for checking the opening/closing of the device before handling.
 - ⑤ Instructions on major overhaul and recommended frequency of inspections.
- (5) Test report as described in Article 9.5 (3). As an alternative, the instruction manual may include the terms “A copy of test report may be used at the request of the Purchaser”.
 - (6) Fluidity test data, including the flow under positive and negative pressures, action sensitivity, flow resistance, flow velocity and the maximum pipe length on the inlet side.
 - (7) Work’s certificate indicating that the device is manufactured and tested according to this Guideline.
 - (8) Necessary safety warning;
 - (9) Fault emergency treatment.

The manual is to be provided in both Chinese and English, or may be in English only if the user is a non-Chinese ship owner.

7.9 Marking

Each device is to be stamped with a permanent mark or a permanently fixed label made of stainless steel or other corrosion-resistant material, indicating:

- (1) Name and trademark of the manufacturer;
- (2) Type, model or other identification, which constitutes the unique ID of the device;
- (3) Size of the inlet and outlet (if any);
- (4) Serial number;
- (5) Approved mounting position, including the maximum or minimum length pipe (if any) between the device and the atmosphere, as well as the classification (explosion-proof grade) of the test device;
- (6) Direction in which fluids flow through the device;

- (7) Laboratory and test report number;
- (8) Pressure setting and vacuum;
- (9) Requirements of MSC/Circ.677 as amended by MSC.1/Circ.1324 and MSC/Circ.1009.

The marking is to be provided in both Chinese and English, or may be in English only if the user is a non-Chinese ship owner

7.10 Order information

According to this Guideline, the order of valves is to include the following information:

- (1) Nominal pipe size, type and length;
- (2) Molecular weight and specific heat, and MESG (if known) of each gas or vapor in the protected liquid cargo tank;
- (3) Inspections and tests (refer to Article 10) other than those as specified herein;
- (4) Pressure setting and vacuum for opening;
- (5) Anticipated ambient air temperature range;
- (6) Making materials (see Article 7.2 of this Guideline and Appendix B of ISO15364);
- (7) Maximum required standard air flow rate and the design pressure drop for the piping system at that maximum flow rate, as well as the maximum allowable tank design pressure/vacuum.

8 Selection of typical samples

8.1 For type approval of single-specification products, the manufacturer is to randomly take any one of the units to the type test.

8.2 For type approval of products of the same model/plan number or of different models/plan numbers, the manufacturer is to take one unit per model and size to the test. Any change in the design, material or manufacturing that may influence the corrosion resistance, or in the flow characteristic will be considered as a change of the type pursuant to this article. However, the fire test of the flame arrester may be limited to the minimum and the maximum sizes per type as well as an intermediate size randomly taken by CCS. Devices are to have the same size and the most unfavorable gap among the products of that type. High-velocity vent valves and pressure/vacuum valves are to be tested again if they are modified during the implementation of test procedure.

8.3 After approval, products are to be subject to the unit/batch inspection according to Article 10 of this Guideline.

9 Type test

9.1 The type approval test is to be carried out at a laboratory accredited by CCS. The manufacturer is to select a laboratory which is qualified and approved by the Administration or certified by the CCS Laboratory to perform the tests specified in this Guideline, and possesses or has access to necessary instruments, tools, personnel and calibration equipment. The manufacturer may perform

all or part of the tests specified in this Guideline under the witness of the Surveyor provided that it has proven to CCS its qualification for proper performance.

9.2 Test principle

- (1) For high-velocity vent valves and pressure/vacuum valves which are used for protecting liquid cargo tanks carrying flammable atmospheres containing liquids as described in Article 1.1 of this Guideline, the gasoline vapor (mainly comprising lead-free petroleum fractions of hydrocarbon with chains with boiling point of about 65°C ~ 75°C), industrial hexane vapor or industrial propane may be used according to the applicable condition or this Guideline, however, this does not exclude the use of gasoline vapor or industrial hexane vapor in all the tests as described in this section.
- (2) After related test, high-velocity vent valves and pressure/vacuum valves are to exhibit no mechanical damage impairing their original performance.
- (3) Before the test, the following devices (if applicable) are to be properly calibrated:
 - ① Gas concentration meter;
 - ② Thermometer;
 - ③ Flow meter;
 - ④ Pressure gauge;
 - ⑤ Time recorder.
- (4) Samples are to be subject to the following inspections:
 - ① Visual and dimension inspection: The product structure and dimension, use of materials, casting quality, machining quality, assembly quality, identification and marking main parts dimensions and dimensions and gaps of affecting fire resistance are to be compliant with the applicable requirements of the approved plans and this Guideline.
 - ② Structure inspection: High speed vent valves and pressure/vacuum valves are to be disassembled and assembled according to the operation instructions and verified for design compliance with Articles 7.2 (1), 7.2 (2), 7.5 (1) and 7.7 (1).

9.3 Test items:

- (1) Samples of high speed vent valves and pressure/vacuum valves selected according to Article 8 of this Guideline are generally to be subject to the following type tests:
 - ① Corrosion test. (For combination of materials allowed in the product design, refer to Article 9.4 (1))
 - ② Hydraulic test. (Refer to Article 9.4 (2))
 - ③ Air pressure test. (Refer to Article 9.4 (3))

- ④ Test and verification of performance characteristic as indicated on the manufacturer's ID, such as the flow under positive and negative pressures, action sensitivity, flow resistance and flow velocity. The fluidity test is to be performed in accordance with Article 9.4 (4).
- ⑤ Pressure test of opening/closing of pressure valves. (Refer to Articles 9.4 (4) and 9.4 (6))
- ⑥ Flow velocity test. (Refer to Articles 9.4 (4) and 9.4 (6))
- ⑦ Pressure test of opening/closing of vacuum valves. (Refer to Articles 9.4 (4) and 9.4 (6))
- ⑧ Flashback test of pressure valves. (Refer to Articles 9.4 (5) ~ (6))
- ⑨ Fire test of pressure valves. (Refer to Article 9.4 (5) ③)
- ⑩ Flashback test of vacuum valves. (Refer to Articles 9.4 (5) ~ (6))
- ⑪ Operation test with inclination of 10°C. (Refer to Article 9.4 (6))
- ⑫ Freezing test and dry heat test. (Refer to Article 9.4 (8))
- ⑬ Inspection of other design functions. (Refer to Article 9.4 (9))
- ⑭ Auxiliary devices (if applicable). (Refer to Article 9.4 (10))
- ⑮ Working stability test of dual valve group (if applicable). (Refer to Article 9.4 (11))
- ⑯ Type test items which are designated by the manufacturer and specified in the explicit product design standards (if applicable); Undamped oscillation tests should be carried out if it refer to ISO15364-2007/2016/2021 (Refer to Article 9.4 (12))

Tests as described in the above Paragraphs ④ ~ ⑧ and ⑩ are to be carried out under the maximum and the minimum allowable design pressure settings of high-velocity vent valves and pressure/vacuum valves.

9.4 Test procedure and method

- (1) Corrosion test. This test is to be performed by keeping the whole device together with the connected pipe sections in the spray of 5% sodium chloride solution at 25°C for 240 h, and then drying for 48 h, alternatively, an equivalent test acceptable to CCS is of the same effect. After the test, all movable parts are to function correctly without indelible corrosion and deposits.
- (2) Hydraulic test. The pressure-bearing interface is to be subject to the hydrostatic test with duration of 10 min under at least 150% × maximum rated pressure (MRP) or the minimum gauge pressure of 3,450 hPa (hPa) (GP 50 lb/in²), whichever is the greater. Then the device is to exhibit no rupture, leakage or permanent deformation. For the purpose of the test, the valve disc may be closed or clogged.
- (3) Air pressure test.

- ① Each finished device is to go through the air pressure test under 70kPa (10 lb/in²), or by means of immersion or soapy water with duration of 3 min during which no leakage is permitted (except for the disc-seat contact sealing face);

Each finished device shall be leakage tested at 75% of the nominal setting to verify that the leakage is below the maximum leakage rate determined by the manufacturer if ISO15364-2016/2021 is referred to;

- ② For vacuum valves in which the internal air pressure falls to 21kPa, no bubbles in succession are allowed on the disc-seat contact sealing face.
- ③ For pressure valves in which the internal air pressure falls to 50% of pressure setting, no bubbles are allowed on the disc-seat contact sealing face.

(4) Fluidity test

- ① Flow determination

The flow of pressure/vacuum valves is to be determined through the fluidity test by taking at least one sample from the venting arrangements per model and size under the conditions listed in Paragraph ②.

- ② Flow data

- (a) The flow data is to be graphed or tabularized, and the volume of fluid which flows through the inlet of high-velocity vent valves, pressure/vacuum valves and vent caps (if applicable) are to be provided and inclusive of the data over the range from the opening pressure/vacuum to the pressure /vacuum at which the inlet fully opens and the valve reaches the maximum expected flow velocity. The flow coefficient is to be used to represent the flow data of the venting element or device which fully opens under the air pressure setting or vacuum (including the maximum and the minimum design and setting values) and is controlled by the servo motor, i.e. the ratio of the flow of the vent to that of the nozzle which is of the same diameter and sound theoretically. Sufficient measurement is to be made for pressures close to the opening point, especially for the pressure setting 1.1, 1.2 and 1.5 times the pressure and the vacuum pressure setting 1.5 and 2.0 times the pressure, the flows are required to be clearly indicated on the chart. The test cabinet accommodating the venting arrangement is generally to have the pressure rise rate of not greater than 0.01 N/mm²/min.

- (b) The flow data is to indicate the initial opening point and final closing point of venting arrangements.

- (c) The flow data is to be expressed in m³/h for the temperature of 0°C (32°F) and air pressure of 1,015 hPa (14.7 lb/in²).

- (d) Pressures are to be expressed in hPa, and auxiliary units are to be millimeter of water, and other units of measurement if so requested.

- (e) The flow data is to include presentations of valve assembly and test methods, together

with a description on the pipes connected to the inlet and outlet. Any medium other than air used in the test is to be indicated in the test report, together with the temperature and the specific gravity of the medium used in standard state.

③ Installation of fluidity testing device

In addition to the recognized national or international standards (e.g. ISO15364:2016), venting arrangements are to be installed according to the following requirements:

- (a) To minimize the influence of inlet loss, venting arrangements are to be installed on the top of the test cabinet, near the center of a basically flat area of a diameter at least 5 times greater than the nominal diameter of the tested valve.
- (b) Valves are to be installed on the straight connector with the same nominal diameter and a length 1.5 times the nominal diameter, to ensure the proposed flow measurement in line with the recognized national or international standards. The pipe connector is to be vertically introduced into the top of the test cabinet from around the center of the flat area, with the fitting end entering the test cabinet at an axial angle of 90° to the axis. The bending radius of the inducer is to be no greater than 80 mm (3.1 in).
- (c) The testing apparatus or instrument is to have the accuracy error within $\pm 5\%$.

④ Related requirements:

- (a) The measured rated flow is to be no less than the design value indicated in the plan promised by the manufacturer;
- (b) Where the internal air pressure reaches 70% of pressure setting, no bubbles in succession or audible air leaks are allowed on the sealing face of the valve disc;
- (c) Where the internal air pressure reaches 80% or 75% of pressure setting, the leakage rate for the maximum standard air volume is to be tested and recorded, which is to be conform to the design requirements;
- (d) Pressure/vacuum valves are to open under the pressure setting (error within $\pm 3\%$);
- (e) The difference between the opening and closing pressures of pressure/vacuum valves are to meet the product design requirements, which are generally to be no less than 65%;
- (f) The valve disc is to open and close quickly, operate smoothly without abnormalities such as shock and hammering.

(5) Test procedure for flame arresters at the opening open to the atmosphere

- ① The test equipment is to be a flashback test device composed of a device generating the explosive gas mixture, a small container with a diaphragm, a sample of flame arrester connected with a flange, a plastic bag (note: size to be depending on that of the flame arrester, or with perimeter of 2 m, length of 2.5 m and wall thickness of 0.05 mm for flame arresters for oil tankers) and ignition sources at three positions (see Fig. 9.4 (1))

(Note: To prevent residues of the plastic bag falling to the test device after ignition of the fuel-air mixture, it may be helpful to provide a stand of thick metal wire at the crossover device in the plastic bag, provided that the stand is of the construction not interfering with the test result.). Alternatively, other test equipment may be used, as long as they could make the test specified in this Guideline acceptable to CCS.

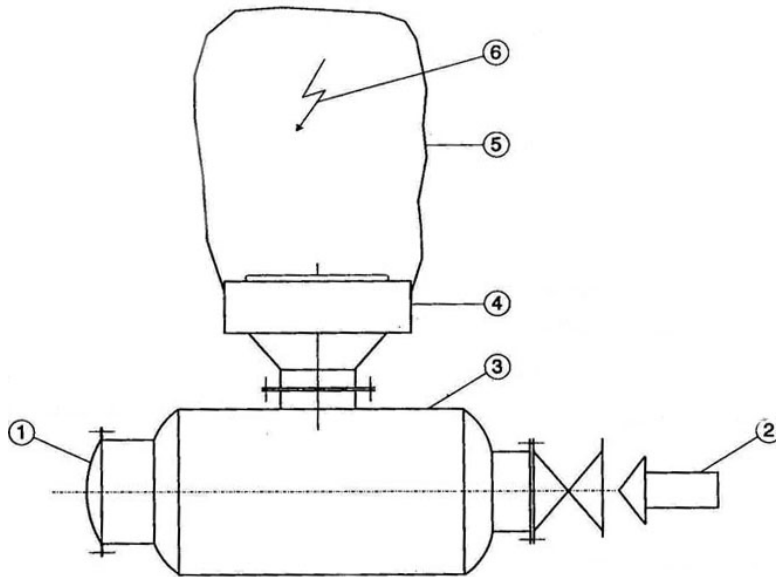

1. Bursting disc; 2. Inlet of explosive gas mixture; 3. Gas reservoir; 4. Flame arrester; 5. Plastic bag; 6. Ignition source

Fig. 9.4 (1) Flashback test device

- ② The flashback test is to be carried out as follows:
- (a) The container, flame arrester assembly and the plastic bag covered on the sample of flame arrester are to be filled with the most easily ignitable propane-air mixture (refer to IEC60079-1A) which is to be verified for concentration by testing the gas composition in the plastic bag. When testing a device as described in Article 7.6 (6), the plastic bag is to be arranged at the outlet open to the atmosphere. The three ignition sources are to be furnished along the axis of the plastic bag, with one being closing to the flame arrester, one as far away from the flame arrester as possible and another one at the midpoint between these two points. These sources are to keep igniting, with each point igniting twice. The test gas is to be within the temperature of 15°C ~ 40°C;
 - (b) Where flashback occurs, the bursting disc as shown in Fig. 9.4 (1) will burst, which could be heard and seen by the operator through flame radiation, and could be achieved through a flame/heat/pressure sensor.
- ③ If it is expected that explosive gas flow may be present at the outlet of the flame arrester, the fire test is to be carried out in addition to the flashback test:
- (a) The plastic bag may be substituted by the test equipment as described in the above Article 9.4 (5) ①. The flame arrester is to be installed to ensure a vertical jet gas mixture which is to be ignited here. During the test of the device as described in Article 7.6 (6), the flame arrester is to be arranged at the finalized location;

(b) The fire test is to be performed with the most easily ignitable gasoline vapor/industrial hexane-air mixture, accompanied by the pilot flame or spark igniter in continuous operation provided at the outlet. The test gas is to be introduced from upstream of the container, as shown in Fig. 9.4 (2), and maintained at concentrations above by changing the flow velocity until one side of the liquid cargo tank is heated to the maximum attainable temperature. Measurement is to be done for the temperature such as the temperature of the side protected by the flame extinguishing matrix of the flame arrester (or of the valve seat in the high-velocity venting test according to Article 9.4 (6)). Where temperature rise rate within 10 min does not exceed $0.5^{\circ}\text{C}/\text{min}$, the maximum attainable temperature is considered to have been reached.

The above temperature is to be maintained for 10 min, followed by stop of gas flow and check of test conditions. The test gas is to be within the temperature of $15^{\circ}\text{C} \sim 40^{\circ}\text{C}$.

Where no temperature rise occurs, the flame arrester temperature sensor is to be checked for proper location, and attention is to be given to the visual record position of stable flame during the first test procedure, with due regard to the location of the borehole required on the fixed component of the flame arrester. Where these measures do not work, a temperature sensor is to be provided on the non-protective side of the flame arrester that is close to the stable flame.

Where it is difficult to set up a stable temperature at high temperature, the following standards are to be taken: When the flow for the maximum temperature during the above test is reached, continue the fire test for another 2 h, then stop the gas flow and check the test conditions. No flashback is allowed during the above test.

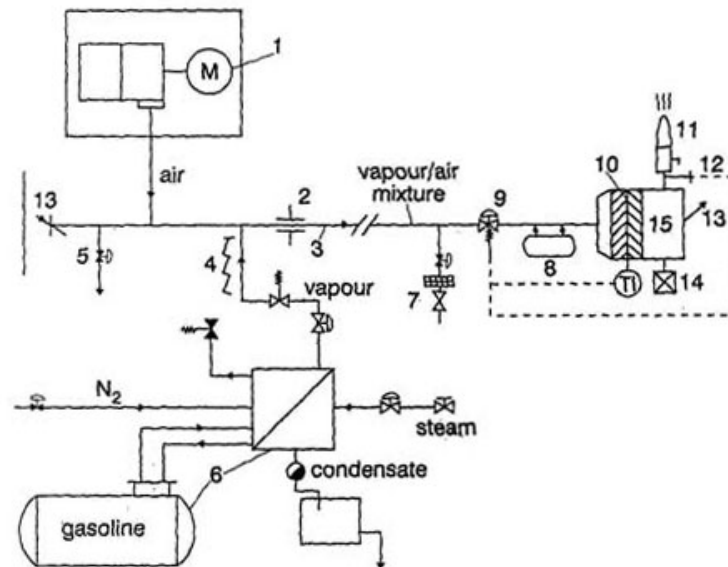

1. Variable speed fan; 2. Volumetric flow meter; 3. Pipe (500 mm in diameter) length: 30 m; 4. Heating steam pipe; 5. Air bypass valve; 6. Evaporator and liquid reservoir; 7. Vapor-air mixture bypass device; 8. Extinguishing agent; 9. Emergency cut-off valve; 10. Temperature-controlled explosion-proof corrugated tape ensuring the safety of test device; 11. Tested high-velocity valve; 12. Flame detector; 13. Burst disc; 14. Concentration indicator; 15. Gas reservoir

Fig. 9.4(2) Schematic diagram of high-velocity valve test device (for fire test only)

- ④ Where the flame arrester comes with a pressure or/and vacuum valve, the flashback test must be performed with the pressure and/or vacuum valve opened; where the pressure valve has no associated flame arresting element, it must be tested as the high-velocity vent valve according to Article 9.4 (6).
- ⑤ If the device adopts ISO15364:2021 standard, the flashback test and endurance burning test shall also meet the requirements of ISO16852:2016.

(6) Test procedure for high velocity vent

- ① The applicable test device is to be the one providing the required volume flow, as shown in Figures 9.4 (2) and 9.4 (3), or other devices acceptable to CCS.
- ② The fluidity test is to be performed for devices including the high velocity vent, with the compressed air or other gas under the permitted flow, with the followings recorded:
 - (a) Flow. Where the air or gas other than cargo vapors applicable for venting arrangement is used during the test, consideration is to be given to the influence of density of these cargo vapors and correction is to be made for the obtained flow;
 - (b) Pressure before the venting arrangement opens. The test cabinet accommodating the venting arrangements is to have the pressure rise rate of not greater than $0.01 \text{ N/mm}^2/\text{min}$;
 - (c) Pressure setting of the venting arrangement;
 - (d) Closing pressure of the venting arrangement;
 - (e) After the valve opens, the gas velocity at the nozzle is to be no less than 30 m/s at any time.

The test is to be performed in line with Article 9.4 (4) ④ by measuring the flow and the gas velocity at the nozzle with the high-velocity vent valve opening under different states (for different flows). The gas velocity at the nozzle is to be no less than 30 m/s at any time and the flow is to meet the plan design requirements.

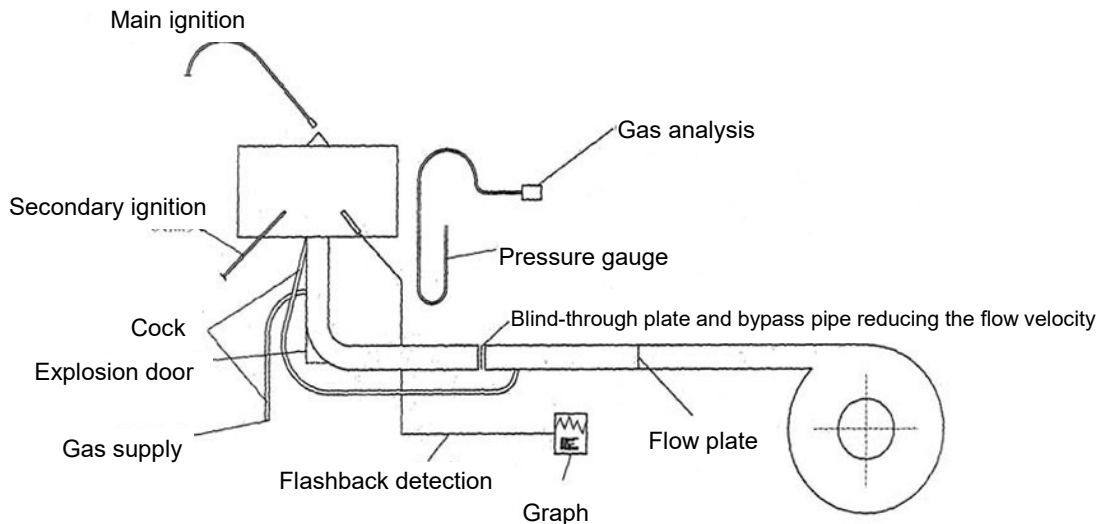
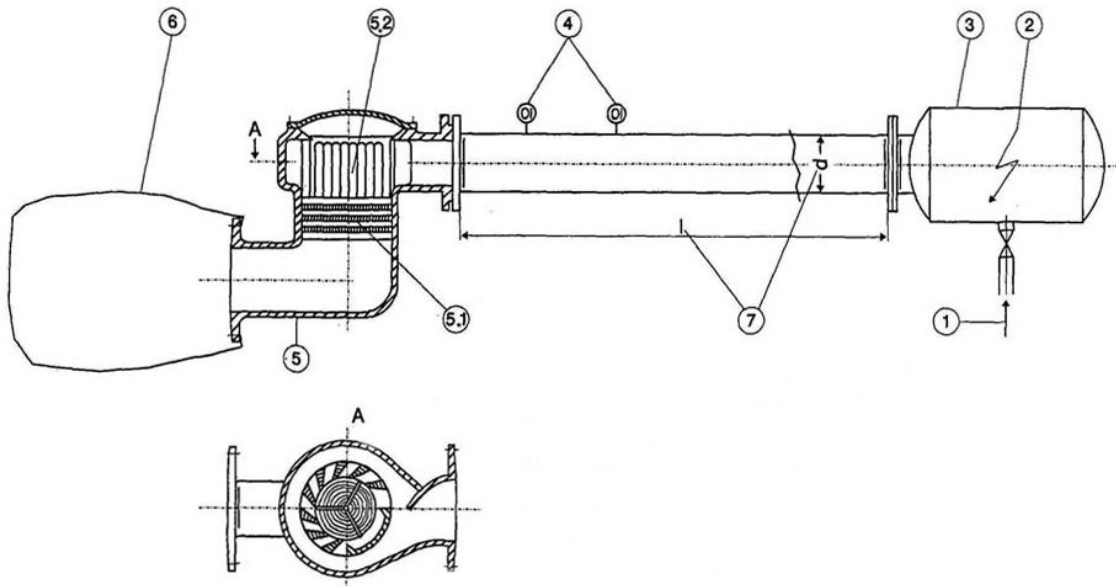

Fig. 9.4(3) Test device of high-velocity vent valve

- ③ A test is to be performed for fire safety under the conditions as set forth in Article 7.4(6) by using the most easily ignitable gasoline vapor/industrial hexane-air mixture which is to be ignited by means of the permanent pilot flame at the outlet or the spark igniter:
- (a) During the flashback test using the propane in place of gasoline or hexane, the venting arrangement is to be installed in a vertical direction and at an inclination of 10° to this vertical direction. In view of the design, some venting arrangements are to be further tested in more than one direction of tilt. During each of the above tests, flow is to be reduced until the venting arrangement closes and the flame goes out, and each test is to be repeated 50 times at least. To verify the effectiveness of the required device, a test is to be carried out for the vacuum side of the combination valve with the vacuum valve opening according to Article 9.4 (5) ②;
 - (b) The fire test as described in Article 9.4 (5) ③ is to be performed. After the test, put out the main flame, keep the pilot flame burning or use the spark igniter for ignition, allow escape of a little ignitable gas mixture and maintain the valve at $< 90\%$ pressure setting for 10 min during which no flashback is allowed. For this purpose, the soft seal or soft valve seat is to be removed during the test.
 - (c) If the high-speed vent valve refers to ISO15364:2021, air deflagration test, low flow flame transmission test, flame transmission test by opening and closing, deflagration test and endurance burning test shall also be carried out, and the test device and technical requirements shall meet the requirements of ISO16852:2016.
- (7) Test device and procedure for the tandem detonation flame arrester
- ① The flame arrester is to be installed on one end of a pipe with an appropriate length and the same diameter as its flange, with the flange on the other end attached with a pipe section 10 times the pipe diameter and sealed with a plastic bag with perimeter of 4 m, length of 4 m and material thickness of 0.05 mm or a diaphragm. The pipe is to be filled with easily ignitable propane-air mixture which then is to be ignited. Measurement is to be made for the flame speed close to the flame arrester, with a steady detonation value provided.
 - ② The detonation test is to be performed three times without flashback in the device and damage or permanent deformation in the component of the flame arrester.
 - ③ The test device is to be as shown in Fig. 9.4 (4), or the one acceptable to CCS.
 - ④ If the flame arrester refers to ISO15364:2021, the deflagration test and endurance burning test shall also be carried out, and the test device and technical requirements shall meet the requirements of ISO16852:2016.



1. Inlet of explosive gas mixture; 2. Ignition source for non-flowing gas mixture; 3. Gas reservoir; 4. Measuring system for flame speed in steady detonation; 5. Tandem flame arrester; 5.1. Element of flame arrester; 5.2. Surge absorber; 6. Plastic bag; 7. $l / d \approx 100$

Fig. 9.4 (4) Tandem flame arrester test device

(8) Freezing test and dry heat test

- ① Keep the high-velocity vent valve and pressure/vacuum valve at -30°C or a lower temperature depending on the product design for 24 h, then take them out and immediately check that all parts work properly and the valve disc opens and closes flexibly and reliably when being manually operated with the valve stem.
- ② External icing test: Use the artificial simulated rainfall or other method (refer to ISO15364:2007/2016/2021) to obtain an ice layer with thickness of at least 5 mm or of the allowable value indicated in the operation manual at -10°C , whichever is the greater. The device is to be capable of working properly after being deiced with a manual device without the use of a heating device.
- ③ Internal icing test: For products without a heating device and applicable for cargo vapor freezing environment, icing is to be done inside the device by freezing the cargo vapor through manual simulation at -10°C at least between the shaft sleeve and the shaft, the valve disc and the valve seat. The device is to be capable of working properly after being deiced with a manual device.
- ④ Keep the high-velocity vent valve and pressure/vacuum valve at 65°C or a higher temperature depending on the product design for 24 h, then take them out and immediately check that all parts work properly and the valve disc opens and closes flexibly and reliably when being manually operated with the valve stem.

(9) Other functional checks

- ① Check of manual lifting device. Manually operate the pressure/vacuum valve stem as specified in the product operation manual, the valve disc is to open and close flexibly and reliably, and the valve position detection is to meet the requirements of Article 7.2 (8).

- ② The device is to be checked for drainage and discharge of condensate by simulation, with the result compliant with Articles 7.2 (12) and 7.2 (13).
- ③ The device is to go through the hose test (refer to the test method for the second characteristic numeral 5 of IP degree specified in IEC 60529), with the result compliant with Article 7.2 (16).

(10) Auxiliary device (if applicable).

- ① A device with a heating & deicing device or melting & crystallizing device is to be subject to necessary tests including:
 - (a) Perform the hydraulic test with duration of 5 min for the bearing housing under $150\% \times$ maximum allowable working pressure (≥ 3 bar) with the test medium at the maximum allowable heating temperature; the housing is to exhibit no abnormality;
 - (b) After the hydraulic test, maintain the pressure at the maximum allowable working pressure, and manually check the valve disc for reliable and flexible opening and closing, and check the temperature distribution which is to meet the plan design requirements.
- ② A device with a cleaning unit is to go through the simulation test for verification of cleaning effect which is to meet the plan design requirements.

(11) Working stability test of dual valve group

The dual valve groups are to be verified through working stability test:

- ① Set the opening pressure of the two valves respectively, with the difference between them being the minimum allowable value specified in the product operation manual; perform the fluidity test according to Article 9.4 (4), and the valve is to operate stably within the design rated flow without hammering and other instabilities. If the design opening pressure is an interval, the test is to verify the operation under the minimum and the maximum pressure settings at least.
- ② The working stability test is to include the pressure valve and vacuum valve.

(12) Type test items which are designated by the manufacturer and specified in the explicit product design standards (if applicable).

Tests specified in the selected standard which are out of the provisions of this chapter are to be in accordance with the selected standard, such as the undamping oscillation test as specified in ISO15364:2007/2016/2021

9.6 Test record and report

- (1) The following characteristic parameters are to be recorded as appropriate throughout the test:
 - ① Concentration of gas mixture;

- ② Temperature of gas mixture when entering the device; and flow of gas mixture (if applicable).
- (2) On the protection side of the device, the passage of flame is to be observed and recorded for the temperature, pressure or light radiation by using an appropriate sensor or video tape.
- (3) Test report
 - ① The laboratory is to prepare a test report for each sample and each finished valve, including:
 - (a) Verified details of the device and its components;
 - (b) Test type and the result inclusive of verifiable test data record; for the test of tandem arrangements, the information is to include the maximum pressure in the test and the observed maximum speed;
 - (c) Special instruction on the approved annex;
 - (d) Type of cargo approved to be used in the device;
 - (e) Test device plan, including the description of the provided inlet and outlet pipelines;
 - (f) The pressure under which the high velocity vent opens and closes at the jet velocity;
 - (g) All data records of markings on the device according to Article 7.9 of this Guideline;
 - (h) Operation manual provided by the manufacturer, and
 - (i) Report number.

10 Unit/batch inspection

10.1 Quality assurance

- (1) The manufacturer is to ensure that the device satisfies the characteristic of the CCS sample approval test in terms of design, manufacturing and test.
- (2) The manufacturer is to maintain the quality of the device designed, tested and marked according to this Guideline, and fulfill its commitment of conforming to this Guideline. Devices not conforming to this Guideline are not allowed to be stamped with markings related to CCS inspection requirements for publicity and selling.

10.2 Inspection

- (1) The manufacturer is to submit all the necessary conditions and documents to the Surveyor to demonstrate compliance with this Guideline, which generally include:
 - ① Supporting documentation of materials for valve housing, core and seat;
 - ② Information about the flame screen.

③ Factory inspection and test reports (inspection and test items in line with Articles 10.2 (2) ~ 10.4);

④ Declaration of conformity or certificate (Refer to Article 10.1 for content)

(2) Each finished device is to be subject to the visual and dimensional inspections to ensure compliance with the requirements of this Guideline, including Article 7.10 “Order information”, the instruction manual specified in Article 7.8 and marking specified in Article 7.9. Special attention is to be paid to the sufficiency of welding point and proper assembly of the joint.

10.3 The unit/batch inspection after approved for the following items:

(1) Visual inspection: The product structure, use of materials, casting quality, machining quality and assembly quality are to be compliant with the requirements of approved plans.

(2) Hydraulic test of bearing housing: The device is to be tested according to Article 9.3 (1) ② and then exhibit no bursting, leakage and permanent deformation.

(3) Air pressure test: According to Article 9.3 (1) ③ .

(4) Pressure test of opening/closing of pressure valves: According to Article 9.3 (1) ③ . Check the pressure setting which is to be compliant with the approved plans and order requirements.

(5) Flow velocity test: According to Article 9.3 (1) ④ . When the valve opens under the pressure setting, measure the flow velocity at its output which is to be no less than 30 m/s for high-velocity vent valves.

(6) Pressure test of opening/closing of vacuum pressures: According to Article 9.3 (1) ④ . The valve is to open under the design opening pressure (according to the approved plans and order requirements, generally no less than - 0.007 MPa) and close and operate stably. After the vacuum valve opens, measure its rated flow which is to conform to the design requirements.

10.4 The manufacturer is to fulfill the following inspection items:

(1) Delivery inspection and test items which are designated by the manufacturer and specified in the explicit product design standards;

(2) Special test items added via the technical contract of ordering (if applicable).

10.5 The manufacturer is required to inspect and test each device concerned for the above items, and apply for inspection to CCS after they have passed the inspection and test. The Surveyor is to perform the field sampling and inspection and test according to the proportion and items as specified in the Inspection Plan issued by CCS in conjunction with the Certificate of Approval.