

Guideline No. W-18 (202307)



**W-18**

**STEEL FORGINGS FOR  
CONTINUOUS GRAIN-FLOW  
INTEGRATED CRANKSHAFTS**

Issued date: July 01, 2023

© China Classification Society

## Foreword

China Classification Society (hereinafter referred to as CCS) Product Inspection and Testing Guideline (hereinafter referred to as this Guideline) contains the technical requirements, inspection and testing criteria related to classification and statutory survey of marine products to be applied for CCS approval/inspection.

This Guideline frees the users to adopt other test methods and requirements which are equivalent to or are stricter than this Guideline.

This Guideline is published and updated by CCS, and is released at <http://www.ccs.org.cn>. Your comments or suggestions are welcomed and may be sent to our email addressed [mp@ccs.org.cn](mailto:mp@ccs.org.cn).

Historical versions and release date: W-18 (201510) October 20, 2015

W-18 (201610) October 28, 2015

W-18 (201705) May 09, 2017

Main changes:

1. Translation of the requirements of Ur W 7(Rev. 4 Feb 2022) , a new resolution adopted by the IACS, into the guidelines, with a revision of 7.2. (3) , 9. (4) ;

2. Textual Amendment 1 clause

## CONTENTS

1 Application.....	4
2 Basis for approval and inspection .....	4
3 Terms and definitions.....	4
4 Plans/documents to be submitted by the applicant.....	5
5 <u>Technical requirements</u> .....	7
6 Materials and components.....	87
7 <u>Type test</u> .....	87
8 <u>Unit and batch inspection</u> .....	89
9 <u>Inspection identification</u> .....	89
10 Type test.....	9
11 Unit and batch inspection.....	10
12 Identification of products .....	10

## STEEL FORGINGS FOR CONTINUOUS GRAIN-FLOW INTEGRATED CRANKSHAFTS

### 1 Application

This Guideline applies to the works approval and product inspection of the steel forgings for the use in the construction of continuous grain-flow integrated crankshaft of marine diesel engine.

This Guideline is the detailed description of Articles 5.1.4.5 and 5.4.2.1, Section 4, Chapter 5, Part One of *CCS Rules for Materials and Welding*.

### 2 Normative references~~Basis for approval and inspection~~

Plan and technical documentation approved by CCS;

Section 4, Chapter 5, Part One of *CCS Rules for Materials and Welding*

### 3 Terms and definitions

For the purpose of this Guideline, the following definitions apply.

Works approval: as defined in Article 3.1.2, Chapter 3, Part One of *CCS Rules for Classification of See-going Ships*

Type test: as defined in Article 3.1.2, Chapter 3, Part One of *CCS Rules for Classification of See-going Ships*

Sample: as defined in Article 3.1.2, Chapter 3, Part One of *CCS Rules for Classification of See-going Ships*

Unit/Batch inspection: as defined in Article 3.1.2, Chapter 3, Part One of *CCS Rules for Classification of See-going Ships*

Inspection: as defined in Article 3.1.2, Chapter 3, Part One of *CCS Rules for Classification of See-going Ships*

**4 Drawings and documents~~List of documentation to be submitted~~**

4.1 The works approval applicants (including the steel-making works and the forging works) are to submit the Application for Approval (the template may be available from the local branch of CCS) and the following documents to the local branch of CCS:

4.1.1 Particulars of manufacturer: name, address, production history, capacity, main products, affiliates (if applicable), business license, legal representative, trademark, etc;

4.1.2 Details of the product (scope of approval application)

- (1) Product name: steel crankshaft forging
- (2) Crankshaft type: integrated
- (3) Forging method: continuous grain-flow forging
- (4) Material category: carbon steel/carbon manganese steel, low alloy steel and alloy steel
- (5) Product specification: max. throw of crank
- (6) Max. weight
- (7) Smelting/deoxidization/casting methods
- (8) Bulk heat treatment status: final heat treatment status
- (9) Surface hardening treatment status: if the forged steel crankshaft is to go through surface hardening treatment by means of carburization, nitridation or high frequency quenching and cold rolling, and
- (10) Processing and delivery status: blank/rough finished/finished

4.1.3 Production process and inspection

- (1) Production process flow chart indicating the inspection/test hold points
- (2) Process documents of main procedures (at least including smelting, refining, casting, forging, heat treatment and surface heat treatment)
- (3) Inspection and test instructions (at least including the requirements for sampling positions and NDT and delivery inspection items);

4.1.4 Information on main production equipment: quantity, name/usage, specification, capacity and other information on the production equipment for smelting, refining, casting, heating, forging (including mold forging), heat treatment, etc.

4.1.5 Information on main test equipment: including equipment for mechanical properties test, chemical composition analysis, metallographic test, NDT and dimensions measurement. For those equipment used for tensile, impact and hardness tests, the manufacturer, model, quantity, serial number and verification status are to be made clear.

4.1.6 Qualification certificates of production and test personnel: at least including the qualification certificates of the personnel to carry out such activities: chemical composition analysis, mechanical properties test, metallographic test and NDT (the NDT personnel are to obtain NDT Certificates acknowledged by CCS);

4.1.7 Organization structure chart and roles and responsibilities of quality control department.

4.1.8 Description on product identification and traceability system, including the method of tracing the product specimen at different stages of production.

4.1.9 Technical conditions for inspection and delivery: standards on product acceptance and delivery (including NDT, packing, marking and certification);

4.1.10 Product mark diagram;

4.1.11 Certificate of quality: template of certificate/document of product quality;

4.1.12 Approval test program: type test program prepared by the applicant and approved by CCS or prepared by CCS and confirmed by the manufacturer, including:

- (1) scope of approval application
- (2) approval basis
- (3) description of basic parameters of type test samples
- (4) items and acceptance standards of type test
- (5) figure of sampling positions
- (6) recommended testing agency
- (7) plans and technical documents (on test samples) approved by CCS
- (8) applicable standards and technical conditions

4.2 The manufacturer that applies for product inspection is to submit the following materials to local CCS branch:

- (1) Application of Product Inspection
- (2) Plans and documents approved by CCS

(3) Plan Approval Comments by CCS.

## **5 Technical requirements**

The plans and relevant technical documents on the marine diesel engine crankshaft are to be approved by the plan approval authority of CCS. In addition, the technical requirements on the crankshaft material are to comply with Section 4, Chapter 5, Part One of *CCS Rules for Material and Welding*.

### **~~Qualifications required for the works applying for approval to CCS~~**

- ~~(1) The manufacturer must be qualified for managing and producing this product;~~
- ~~(2) The manufacturer must have the production equipment and necessary test equipment adaptive to the product within the approval scope;~~
- ~~(3) The manufacturer is to set up and implement a quality assurance system that complies with at least ISO 9000 or other equivalent quality assurance standards;~~
- ~~(4) The manufacturer must prepare corresponding technical documents and inspection and test instructions for different products and procedures so as to guide the whole production, inspection and test course;~~
- ~~(5) The main production (special procedures) and inspection personnel are to be accordingly qualified and have qualification certificate.~~

## **6 Materials and components**

Materials and components are to comply with relevant requirements of CCS Rules.

## **~~7 Welding procedures qualification~~**

~~Not applicable, since the steel crankshaft forgings are not allowed to be welded up.~~

## **~~8 Design and technical requirements~~**

~~The plans and relevant technical documents on the marine diesel engine crankshaft are to be approved by the plan approval authority of CCS. In addition, the technical requirements on the crankshaft material are to comply with Section 4, Chapter 5, Part One of *CCS Rules for Material and Welding*.~~

## **~~9 Selection of typical sample for tType test~~**

7.1 The typical sample is to be selected on the following principles:

- (1) Select at least one typical sample from each category of the materials to be approved.
- (2) Even if the material category is the same, the typical samples are to be made respectively for the type test if the materials are different in heat treatment status (normalized & tempered steel and quenched & tempered steel are to be deemed different).
- (3) For different surface hardening treatment processes, typical steel crankshaft forgings are to be made respectively for the type test.
- (4) At least the finished weight of one typical sample is to be not less than 80% of the maximum finished weight.
- (5) At least the throw of crank of one typical sample is to be or approximate the applied maximum throw of crank.

## 7.2 Test items:~~10~~ Type test

The type test items, sample quantity, sample dimensions and sampling position are to be consulted with and approved by CCS. At least the following test items are to be included:

- (1) Visual inspection: to be carried out carefully on both forged blanks and finished products.
- (2) Magnetic particle test (surface NDT): The test position and standard are to meet the relevant requirements as specified in Appendix 7A of *CCS Guidelines for Inspection of Hull Welds or the technical documents approved by CCS*.
- (3) Ultrasonic test (internal NDT): The test position and standard are to meet the relevant requirements as specified in Appendix 7A of *CCS Guidelines for Inspection of Hull Welds or the technical documents approved by CCS*.
- (4) Tensile test: See Fig. 10(4) for the sampling position. If advanced non-destructive testing (Andt) technology is used, the requirements of Appendix 2 of Part 3 of the material and welding specification shall be met.
- (5) Impact test (if applicable): See Fig. ~~10~~.7.1 for the sampling position.
- (6) Hardness measurement: See Figures ~~10~~.7.1 and ~~10~~.7.2 for the sampling position.
- (7) Chemical composition analysis: C, Si, Mn, P, S, Cr, Ni, Mo, Cu, Nb, V, Ti, Al, N, H, O and other elements intentionally added are to be measured. The smelted sample and the finished sample are to be analyzed respectively. The finished samples are to be taken from the surface and the center of journal (main journal or crank pin journal).
- (8) Microstructure (form of structure and inclusion) inspection: See Fig. ~~10~~.7.1 for the sampling position. The magnification is to be 100X and 500X respectively.
- (9) Grain size: The sampling position is the same as that in the microstructure inspection. It is to be larger than Grade 6.
- (10) Sulfur print inspection: See Fig. ~~10~~.7.1 for the section position.
- (11) Grain flow direction inspection: See Fig. ~~10~~.7.1 for the section position.
- (12) Macrostructure (all segregation and other macro defects) inspection: The sampling position is the same as that in the sulfur print inspection.

For the approval of crankshaft that has gone through the surface treatment, the following approval test items are also to be added.

- (13) NDT (The sample surface defects are to be examined before and after the surface treatment. This can be done by means of magnetic particle test or dye penetration test)

- (14) Hardness distribution, surface hardening depth and residue stress tests (the test is to be carried out in and near the surface treatment area). In case of surface hardening by cold rolling, the deformation of the cold rolling area is to be measured.
- (15) Sulfur print, macrostructure and metallographic structure inspections (to be performed at the section in the depth of hardening).
- (16) Tensile test and bending test (or impact test): One set of samples are to be taken out from the end of the crankshaft after surface treatment.

After the approval test, the manufacturer is to prepare an approval test report which is to be signed by the Surveyor before being submitted to CCS in triplicate. The approval test report is to be enclosed with the calibration certificate of related test equipment.

#### **118 Unit ~~and~~/bath inspection**

- (1) Tensile test
- (2) Impact test
- (4) Magnetic particle test
- (5) Ultrasonic test
- (6) Dimensions/accuracy measurement (if applicable)

#### **129 Identification of products**

Marks along with CCS notation to be clearly marked on the product having passed inspections:

- (1) CCS logo;
- (2) cast number or other marking which will enable the full history of the forging to be traced;
- (3) brand or grade of forging material;
- (4) Date of final inspection;  
~~abbreviated name of the survey unit and personal stamp of Surveyor responsible for inspection;~~
- (5) certificate number.

When the area is not enough for all marks, at least the items (1) to (2) are to be marked. The stamp is to be legible.

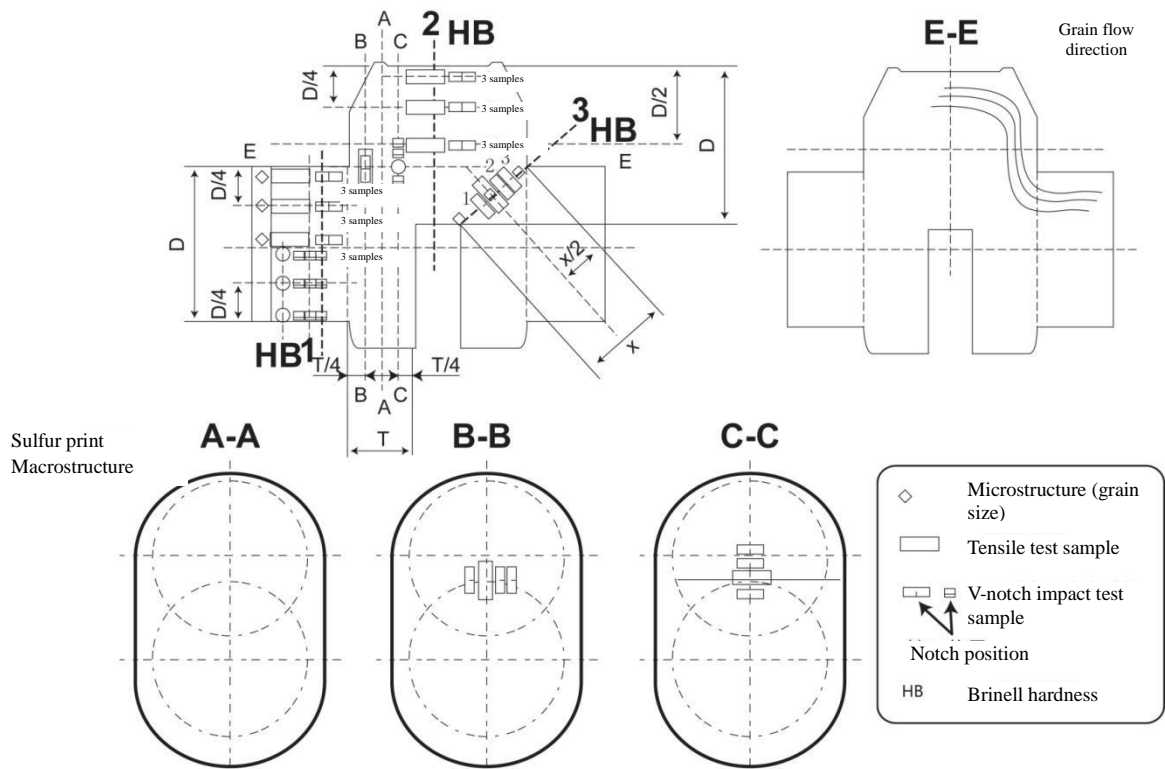

Fig. 107.1 Sampling positions

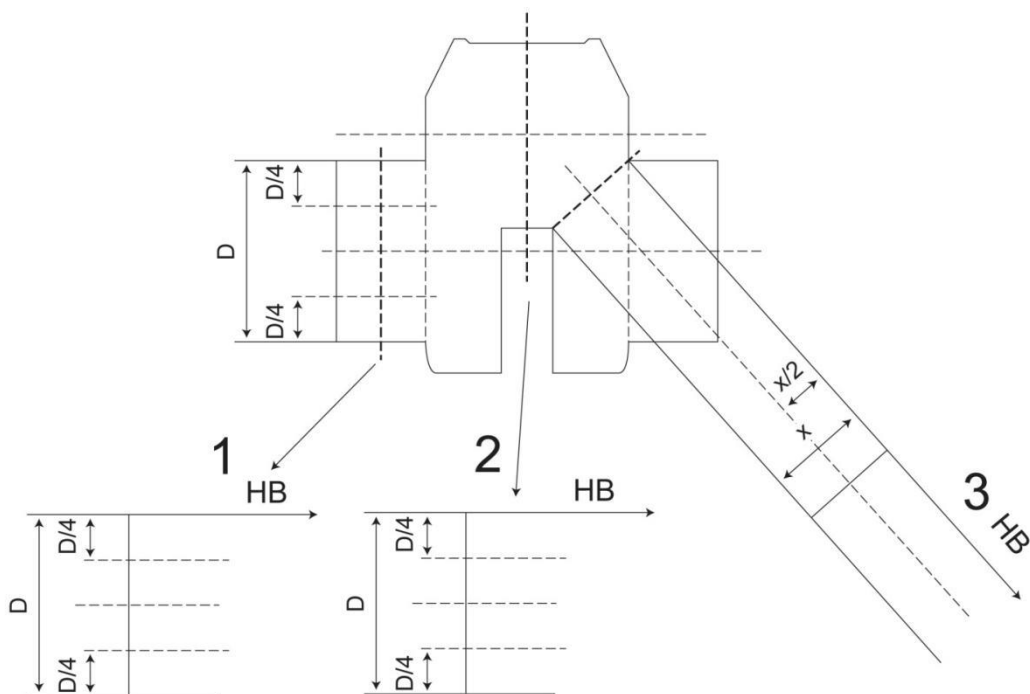

Fig. 107.2 Sampling positions