

RESOLUTION MEPC.334(76)
(adopted on 17 June 2021)

**2021 GUIDELINES ON SURVEY AND CERTIFICATION OF THE ATTAINED ENERGY
EFFICIENCY EXISTING SHIP INDEX (EEXI)**

THE MARINE ENVIRONMENT PROTECTION COMMITTEE,

RECALLING Article 38(a) of the Convention on the International Maritime Organization concerning the functions of the Marine Environment Protection Committee conferred upon it by international conventions for the prevention and control of marine pollution from ships,

NOTING that it adopted, by resolution MEPC.328(76), the 2021 revised MARPOL Annex VI, which is expected to enter into force on 1 November 2022 upon its deemed acceptance on 1 May 2022,

NOTING IN PARTICULAR that the 2021 revised MARPOL Annex VI contains amendments concerning mandatory goal-based technical and operational measures to reduce carbon intensity of international shipping,

NOTING FURTHER that regulation 5 (Surveys) of MARPOL Annex VI, as amended, requires that ships to which chapter 4 applies shall also be subject to survey and certification taking into account guidelines developed by the Organization,

RECOGNIZING that the aforementioned amendments to MARPOL Annex VI require relevant guidelines for uniform and effective implementation of the regulations and to provide sufficient lead time for industry to prepare,

HAVING CONSIDERED, at its seventy-sixth session, draft *2021 Guidelines on survey and certification of the Energy Efficiency Existing Ship Index (EEXI)*,

1 ADOPTS the *2021 Guidelines on survey and certification of the Energy Efficiency Existing Ship Index (EEXI)*, as set out in the annex to the present resolution;

2 INVITES Administrations to take the annexed Guidelines into account when developing and enacting national laws which give force to and implement requirements set forth in regulation 5 of MARPOL Annex VI;

3 REQUESTS the Parties to MARPOL Annex VI and other Member Governments to bring the annexed Guidelines to the attention of masters, seafarers, shipowners, ship operators and any other interested parties;

4 AGREES to keep the Guidelines under review in light of experience gained with their implementation and in light of the review of EEXI regulations to be completed by the Organization by 1 January 2026 as identified in regulation 25.3 of MARPOL Annex VI.

ANNEX

2021 GUIDELINES ON SURVEY AND CERTIFICATION OF THE ATTAINED ENERGY EFFICIENCY EXISTING SHIP INDEX (EEXI)

Table of contents

1	GENERAL
2	DEFINITIONS
3	APPLICATION
4	PROCEDURES FOR SURVEY AND CERTIFICATION
4.1	General
4.2	Verification of the attained EEXI
4.3	Verification of the attained EEXI in case of major conversion
APPENDIX	Sample of EEXI Technical File

1 GENERAL

The purpose of these guidelines is to assist verifiers of the Energy Efficiency Existing Ship Index (EEXI) of ships in conducting the survey and certification of the EEXI, in accordance with regulations 5, 6, 7, 8 and 9 of MARPOL Annex VI, and assist shipowners, shipbuilders, manufacturers and other interested parties in understanding the procedures for the survey and certification of the EEXI.

2 DEFINITIONS¹

2.1 *Verifier* means an Administration, or organization duly authorized by it, which conducts the survey and certification of the EEXI in accordance with regulations 5, 6, 7, 8 and 9 of MARPOL Annex VI and these Guidelines.

2.2 *Ship of the same type* means a ship the hull form (expressed in the lines such as sheer plan and body plan), excluding additional hull features such as fins, and principal particulars of which are identical to that of the base ship.

2.3 *Tank test* means model towing tests, model self-propulsion tests and model propeller open water tests. Numerical calculations may be accepted as equivalent to model propeller open water tests or used to complement the tank tests conducted (e.g. to evaluate the effect of additional hull features such as fins, etc. on ships' performance), or as a replacement for model tests provided that the methodology and numerical model used have been validated/calibrated against parent hull sea trials and/or model tests, with the approval of the verifier.

2.4 *MARPOL* means the International Convention for the Prevention of Pollution from Ships, 1973, as modified by the Protocols of 1978 and 1997 relating thereto, as amended.

2.5 For the purpose of these Guidelines, the definitions in MARPOL Annex VI, as amended, apply.

3 APPLICATION

These Guidelines should be applied to ships for which an application for a survey for verification of the ship's EEXI specified in regulation 5 of MARPOL Annex VI has been submitted to a verifier.

4 PROCEDURES FOR SURVEY AND CERTIFICATION

4.1 General

4.1.1 The attained EEXI should be calculated in accordance with regulation 23 of MARPOL Annex VI and the *2021 Guidelines on the method of calculation of the attained Energy Efficiency Existing Ship Index (EEXI)* (resolution MEPC.333(76)) (EEXI Calculation Guidelines).

4.1.2 The 2013 Guidance on treatment of innovative energy efficiency technologies for calculation and verification of the attained EEDI (MEPC.1/Circ.815) should be applied for calculation of the attained EEXI, if applicable.

¹ Other terms used in these Guidelines have the same meaning as those defined in the *2018 Guidelines on the method of calculation of the attained EEDI for new ships* (resolution MEPC.308(73), as amended) and the *2021 Guidelines on the method of calculation of the attained EEXI* (resolution MEPC.333(76)).

4.1.3 The information used in the verification process may contain confidential information of submitters, including shipyards, which requires Intellectual Property Rights (IPR) protection. In the case where the submitter wants a non-disclosure agreement with the verifier, the additional information should be provided to the verifier upon mutually agreed terms and conditions.

4.2 Verification of the attained EEXI

4.2.1 For verification of the attained EEXI, an application for a survey and an EEXI Technical File containing the necessary information for the verification and other relevant background documents should be submitted to a verifier, unless the attained EEDI of the ship satisfies the required EEXI.

4.2.2 The EEXI Technical File should be written at least in English. The EEXI Technical File should include, but not be limited to:

- .1 deadweight (DWT) or gross tonnage (GT) for ro-ro passenger ship and cruise passenger ship having non-conventional propulsion;
- .2 the rated installed power (MCR) of the main and auxiliary engines;
- .3 the limited installed power (MCR_{lim}) in cases where the overridable Shaft / Engine Power Limitation system is installed;
- .4 the ship speed (V_{ref});
- .5 the approximate ship speed ($V_{ref,app}$) for pre-EEDI ships in cases where the speed-power curve is not available, as specified in paragraph 2.2.3.5 of the EEXI Calculation Guidelines;
- .6 an approved speed-power curve under the EEDI condition as specified in paragraph 2.2 of the EEDI Calculation Guidelines, which is described in the EEDI Technical File, in cases where regulation 22 of MARPOL Annex VI (Attained EEDI) is applied;
- .7 an estimated speed-power curve under the EEDI condition, or under a different load draught to be calibrated to the EEDI condition, obtained from tank test and/or numerical calculations, if available;
- .8 estimation process and methodology of the power curves, as necessary, including documentation on consistency with the defined quality standards (e.g. ITTC 7.5-03-01-02 and ITTC 7.5-03-01-04 in their latest revisions) and the verification of the numerical set-up with parent hull or the reference set of comparable ships in case of using numerical calculations;
- .9 a sea trial report including sea trial results, which may have been calibrated by the tank test, under the sea condition as specified in paragraph 2.2.2 of the EEDI Calculation Guidelines, if available;
- .10 calculation process of $V_{ref,app}$ for pre-EEDI ships in cases where the speed-power curve is not available, as specified in paragraph 2.2.3.5 of the EEXI Calculation Guidelines;
- .11 type of fuel;

- .12 the specific fuel consumption (*SFC*) of the main and auxiliary engines, as specified in paragraph 2.2.3 of the EEXI Calculation Guidelines;
- .13 the electric power table² for certain ship types, as necessary, as defined in the EEDI Calculation Guidelines;
- .14 the documented record of annual average figure of the auxiliary engine load at sea obtained prior to the date of application for a survey for verification of the ship's EEXI, as specified in paragraph 2.2.2.3 of the EEXI Calculation Guidelines, if applicable;
- .15 calculation process of $P_{AE,app}$, as specified in paragraph 2.2.2.3 of the EEXI Calculation Guidelines, if applicable;
- .16 principal particulars, ship type and the relevant information to classify the ship as such a ship type, classification notations and an overview of the propulsion system and electricity supply system on board;
- .17 description of energy saving equipment, if available;
- .18 calculated value of the attained EEXI, including the calculation summary, which should contain, at a minimum, each value of the calculation parameters and the calculation process used to determine the attained EEXI; and
- .19 for LNG carriers:
 - .1 type and outline of propulsion systems (such as direct drive diesel, diesel electric, steam turbine);
 - .2 LNG cargo tank capacity in m³ and BOR as defined in paragraph 2.2.5.6.3 of the EEDI Calculation Guidelines;
 - .3 shaft power of the propeller shaft after transmission gear at 100% of the rated output of motor (MPP_{Motor}) and $\eta_{(i)}$ for diesel electric;
 - .4 shaft power of the propeller shaft after transmission gear at the de-rated output of motor ($MPP_{Motor,lim}$) in cases where the overridable Shaft / Engine Power Limitation is installed;
 - .5 maximum continuous rated power ($MCR_{SteamTurbine}$) for steam turbine;
 - .6 limited maximum continuous rated power ($MCR_{SteamTurbine,lim}$) for steam turbine in cases where the overridable Shaft / Engine Power Limitation is installed; and
 - .7 $SFC_{SteamTurbine}$ for steam turbine, as specified in paragraph 2.2.7.2 of the EEDI Calculation Guidelines. If the calculation is not available from the manufacturer, $SFC_{SteamTurbine}$ may be calculated by the submitter.

A sample of an EEXI Technical File is provided in the appendix.

² Electric power tables should be validated separately, taking into account the guidelines set out in appendix 2 of the 2014 *Guidelines on survey and certification of the Energy Efficiency Design Index (EEDI)* (resolution MEPC.254(67), as amended by resolutions MEPC.261(68) and MEPC.309(73)); consolidated text: MEPC.1/Circ.855/Rev.2, as may be further amended).

4.2.3 The *SFC* should be corrected to the value corresponding to the ISO standard reference conditions using the standard lower calorific value of the fuel oil, referring to ISO 15550:2002 and ISO 3046-1:2002. For the confirmation of the *SFC*, a copy of the approved NO_x Technical File and documented summary of the correction calculations should be submitted to the verifier.

4.2.4 For ships equipped with dual-fuel engine(s) using LNG and fuel oil, the *C_F*-factor for gas (LNG) and the specific fuel consumption (*SFC*) of gas fuel should be used by applying the criteria specified in paragraph 4.2.3 of the *2014 Guidelines on survey and certification of the Energy Efficiency Design Index (EEDI)*, as amended,³ as a basis for the guidance of the Administration.

4.2.5 Notwithstanding paragraphs 4.2.3 and 4.2.4, in cases where overridable Shaft / Engine Power Limitation is installed, or in cases where engines do not have a test report included in the NO_x Technical File, *SFC* should be calculated in accordance with paragraph 2.2.3 of the EEXI Calculation Guidelines. For this purpose, actual performance records of the engine may be used if satisfactory and acceptable to the verifier.

4.2.6 The verifier may request further information from the submitter, as specified in paragraph 4.2.7 of the EEDI Survey and Certification Guidelines, in addition to that contained in the EEXI Technical File, as necessary, to examine the calculation process of the attained EEXI.

4.2.7 In cases where the sea trial report as specified in paragraph 4.2.2.9 is submitted, the verifier should request further information from the submitter to confirm that:

- .1 the sea trial was conducted in accordance with the conditions specified in paragraphs 4.3.3, 4.3.4 and 4.3.7 of the EEDI Survey and Certification Guidelines, as applicable;
- .2 sea conditions were measured in accordance with ISO 15016:2002 or the equivalent if satisfactory and acceptable to the verifier;
- .3 ship speed was measured in accordance with ISO 15016:2002 or the equivalent if satisfactory and acceptable to the verifier; and
- .4 the measured ship speed was calibrated, if necessary, by taking into account the effects of wind, tide, waves, shallow water and displacement in accordance with ISO 15016:2002 or the equivalent which may be acceptable provided that the concept of the method is transparent for the verifier and publicly available/accessible.

4.2.8 The estimated speed-power curve obtained from the tank test and/or numerical calculations and/or the sea trial results calibrated by the tank test should be reviewed on the basis of the relevant documents in accordance with the EEDI Survey and Certification Guidelines, the defined quality standards (e.g. ITTC 7.5-03-01-02 and ITTC 7.5-03-01-04 in their latest revisions) and the verification of the numerical set-up with parent hull or the reference set of comparable ships.

4.2.9 In cases where the overridable Shaft / Engine Power Limitation system is installed, the verifier should confirm that the system is appropriately installed and sealed in accordance with the *2021 Guidelines on the Shaft / Engine Power Limitation system to comply with the EEXI requirements and use of a power reserve* (resolution MEPC.335(76)) and that a verified Onboard Management Manual (OMM) for overridable Shaft / Engine Power Limitation is on board the ship.

³ Resolution MEPC.254(67), as amended.

4.3 Verification of the attained EEXI in case of major conversion

4.3.1 In cases of a major conversion of a ship taking place at or after the completion date of the survey for EEXI verification specified in regulation 5.4.7 of MARPOL Annex VI, the shipowner should submit to a verifier an application for a general or partial survey with the EEXI Technical File duly revised, based on the conversion made and other relevant background documents.

4.3.2 The background documents should include as a minimum, but are not limited to:

- .1 details of the conversion;
- .2 EEXI parameters changed after the conversion and the technical justifications for each respective parameter;
- .3 reasons for other changes made in the EEXI Technical File, if any; and
- .4 calculated value of the attained EEXI with the calculation summary, which should contain, as a minimum, each value of the calculation parameters and the calculation process used to determine the attained EEXI after the conversion.

4.3.3 The verifier should review the revised EEXI Technical File and other documents submitted and verify the calculation process of the attained EEXI to ensure that it is technically sound and reasonable and follows regulation 23 of MARPOL Annex VI and the EEXI Calculation Guidelines.

4.3.4 For verification of the attained EEXI after the major conversion, speed trials of the ship may be conducted, as necessary.

APPENDIX

SAMPLE OF EEXI TECHNICAL FILE

1 Data

1.1 General information

Shipowner	XXX Shipping Line
Shipbuilder	XXX Shipbuilding Company
Hull no.	12345
IMO no.	94112XX
Ship type	Bulk carrier

1.2 Principal particulars

Length overall	250.0 m
Length between perpendiculars	240.0 m
Breadth, moulded	40.0 m
Depth, moulded	20.0 m
Summer load line draught, moulded	14.0 m
Deadweight at summer load line draught	150,000 tons

1.3 Main engine

Manufacturer	XXX Industries
Type	6J70A
Maximum continuous rating (MCR_{ME})	15,000 kW x 80 rpm
Limited maximum continuous rating with the Engine Power Limitation installed ($MCR_{ME,lim}$)	9,940 kW x 70 rpm
SFC at 75% of MCR_{ME} or 83% of $MCR_{ME,lim}$	166.5 g/kWh
Number of sets	1
Fuel type	Diesel Oil

1.4 Auxiliary engine

Manufacturer	XXX Industries
Type	5J-200
Maximum continuous rating (MCR_{AE})	600 kW x 900 rpm
SFC at 50% MCR_{AE}	220.0 g/kWh
Number of sets	3
Fuel type	Diesel Oil

1.5 Ship speed

Ship speed (V_{ref}) (with the Engine Power Limitation installed)	13.20 knots
---	-------------

2 Power curve

(Example 1; case of the EEDI ship)

An approved speed-power curve contained in the EEDI Technical File is shown in figure 2.1.

(Example 2; case of the pre-EEDI ship)

An estimated speed-power curve obtained from the tank test and/or numerical calculations, if available, is also shown in figure 2.1.

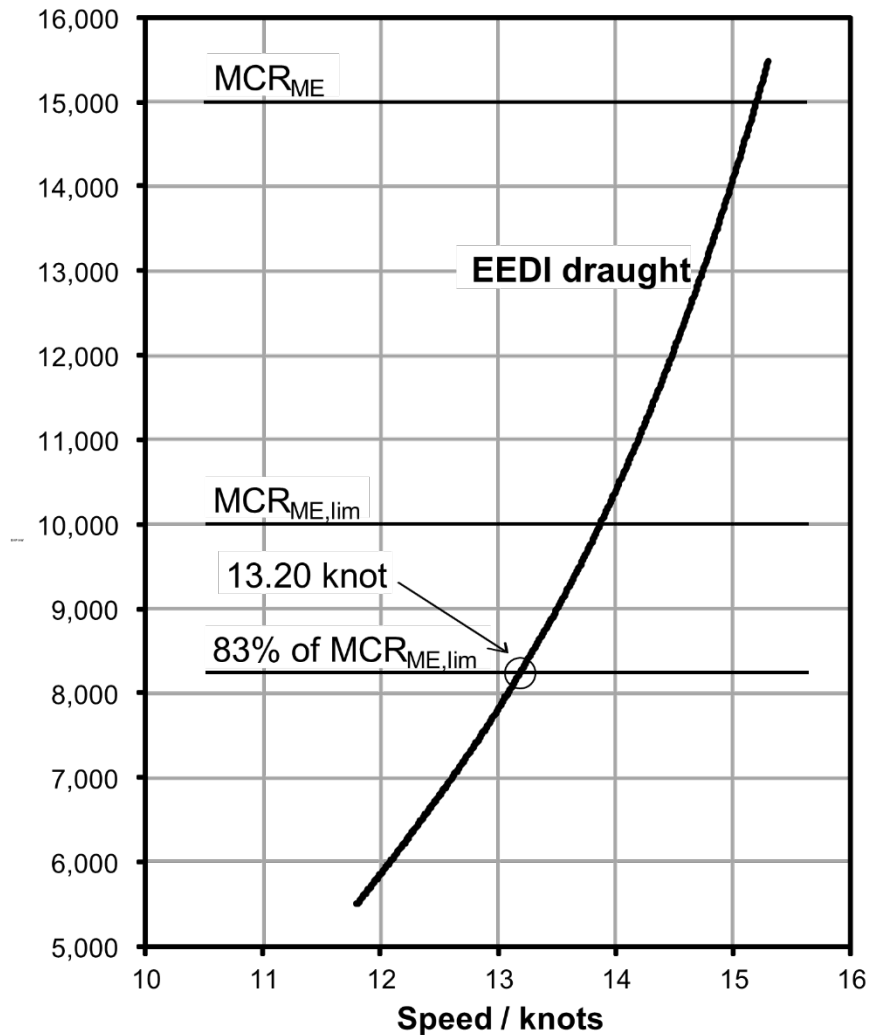

Figure 2.1: Power curve

(Example 3; case of the pre-EEDI ship with sea trial result calibrated to a different load draught)

An estimated speed-power curve under a ballast draught calibrated to the design load draught, obtained from the tank test and/or numerical calculations, if available, is shown in figure 2.2.

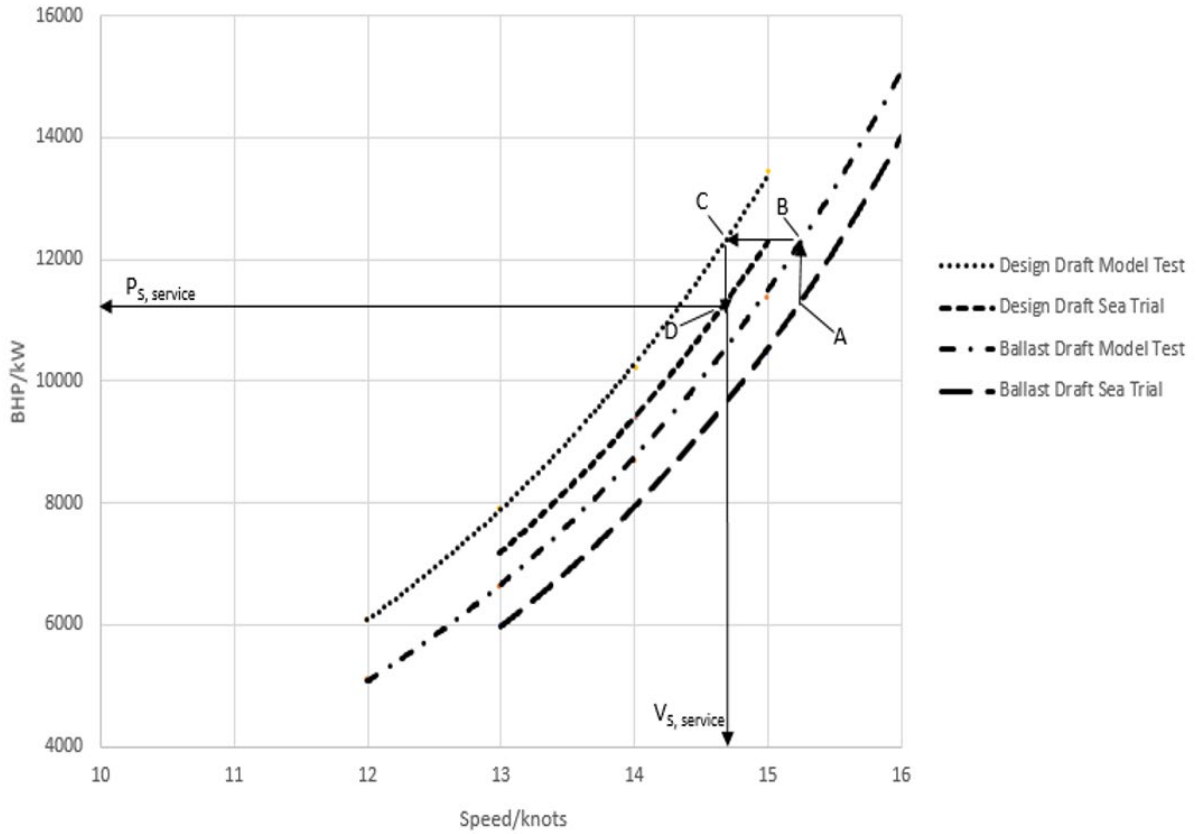

Figure 2.2: Power curve

3 Overview of propulsion system and electric power supply system

3.1 Propulsion system

3.1.1 Main engine

Refer to paragraph 1.3 of this appendix.

3.1.2 Propeller

Type	Fixed pitch propeller
Diameter	7.0 m
Number of blades	4
Number of sets	1

3.2 Electric power supply system

3.2.1 Auxiliary engines

Refer to paragraph 1.4 of this appendix.

3.2.2 Main generators

Manufacturer	XXX Electric
Rated output	560 kW (700 kVA) x 900 rpm
Voltage	AC 450 V
Number of sets	3

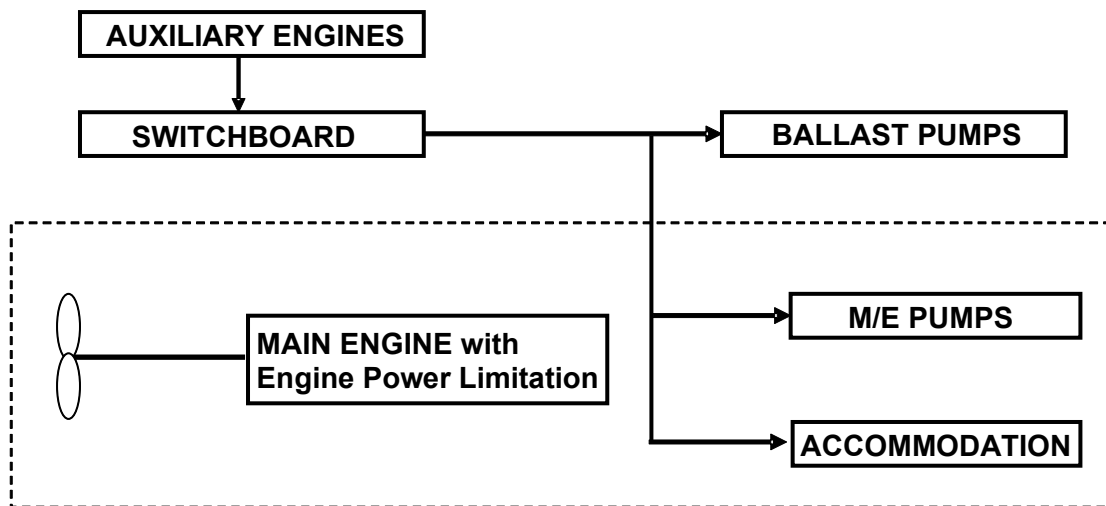

Figure 3.1: Schematic figure of propulsion and electric power supply system

4 Estimation process of speed-power curve

(Example; case of pre-EEDI ship)

Speed-power curve is estimated based on model test results and/or numerical calculations, if available. The flow of the estimation processes is shown below.

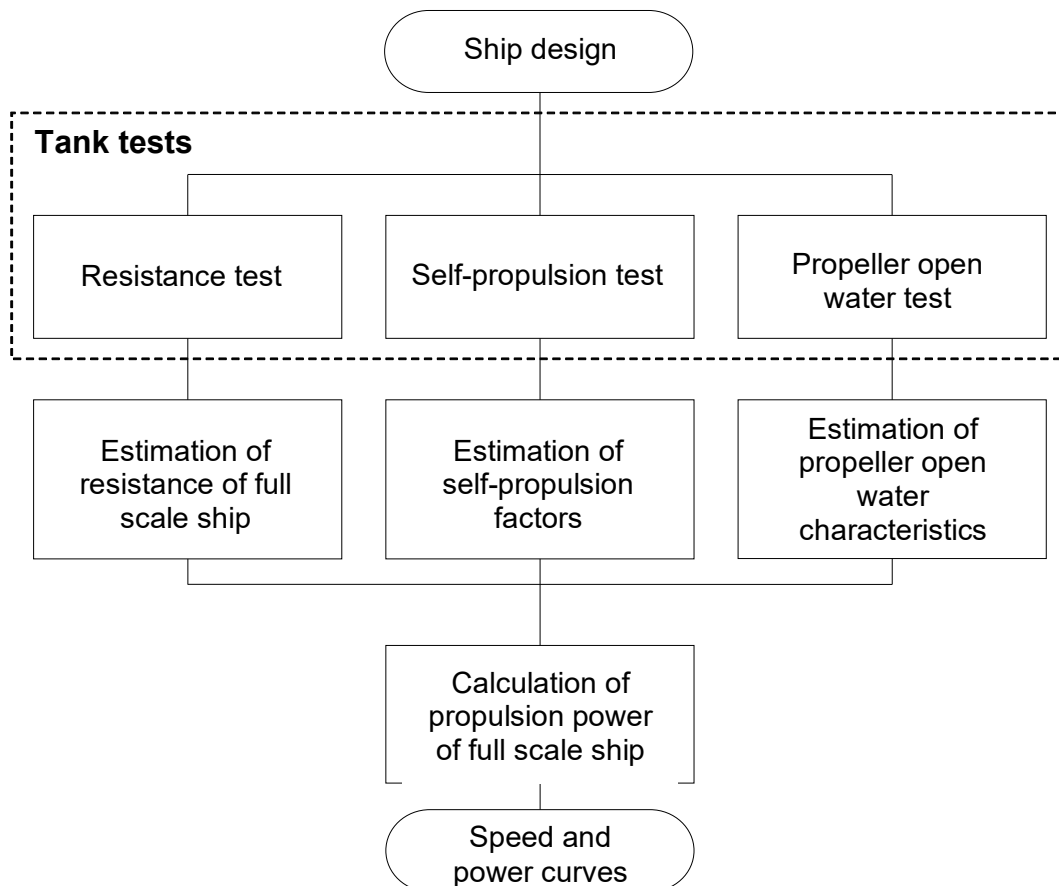

Figure 4: Flow chart of process for estimating speed-power curve from tank tests

5 Description of energy saving equipment

5.1 Energy saving equipment the effects of which are expressed as $P_{AEff(i)}$ and/or $P_{eff(i)}$ in the EEXI calculation formula

N/A

5.2 Other energy saving equipment

(Example)

5.2.1 Rudder fins

5.2.2 Rudder bulb

.....

(Specifications, schematic figures and/or photos, etc. for each piece of equipment or device should be indicated. Alternatively, attachment of a commercial catalogue may be acceptable.)

6 Calculated value of attained EEXI

6.1 Basic data

Type of ship	Capacity DWT	Speed V_{ref} (knots)
Bulk carrier	150,000	13.20

6.2 Main engine

MCR_{ME} (kW)	$MCR_{ME,lim}$ (kW)	P_{ME} (kW)	Type of fuel	C_{FME}	SFC_{ME} (g/kWh)
15,000	9,940	8,250	Diesel oil	3.206	166.5

6.3 Auxiliary engines

P_{AE} (kW)	Type of fuel	C_{FAE}	SFC_{AE} (g/kWh)
625	Diesel oil	3.206	220.0

6.4 Ice class

N/A

6.5 Innovative electrical energy-efficient technology

N/A

6.6 Innovative mechanical energy-efficient technology

N/A

6.7 Cubic capacity correction factor

N/A

6.8 Calculated value of attained EEXI

$$\begin{aligned}
EEXI &= \frac{(\prod_{j=1}^M f_j)(\sum_{i=1}^{nME} P_{ME(i)} \cdot C_{FME(i)} \cdot SFC_{ME(i)}) + (P_{AE} \cdot C_{FAE} \cdot SFC_{AE})}{f_i \cdot f_c \cdot f_l \cdot Capacity \cdot f_w \cdot V_{ref} \cdot f_m} \\
&+ \frac{\{(\prod_{j=1}^M f_j \cdot \sum_{i=1}^{nPTI} P_{PTI(i)} - \sum_{i=1}^{neff} f_{eff(i)} \cdot P_{AEeff(i)}) \cdot C_{FAE} \cdot SFC_{AE}\}}{f_i \cdot f_c \cdot f_l \cdot Capacity \cdot f_w \cdot V_{ref} \cdot f_m} \\
&- \frac{(\sum_{i=1}^{neff} f_{eff(i)} \cdot P_{eff(i)} \cdot C_{FME} \cdot SFC_{ME})}{f_i \cdot f_c \cdot f_l \cdot Capacity \cdot f_w \cdot V_{ref} \cdot f_m} \\
&= \frac{1 \times (8250 \times 3.206 \times 166.5) + (625 \times 3.206 \times 220.0) + 0 - 0}{1 \times 1 \times 1 \times 150000 \times 1 \times 13.20 \times 1} \\
&= 2.45 \text{ (g - CO}_2\text{/ton} \cdot \text{mile)}
\end{aligned}$$

attained EEXI: 2.45 g-CO₂/ton mile