



Guideline No.: P-01(202102)

P-01

PUMPS

Issued date: February 26,2021

© China Classification Society

Foreword:

CCS Product Inspection and Testing Guideline (hereinafter referred to as this Guideline) contains the technical requirements, inspection and testing criteria related to classification and statutory survey of marine products to be applied for CCS approval/inspection.

This Guideline frees the users to adopt other test methods and requirements which are equivalent to or are stricter than this Guideline.

This Guideline is published and updated by CCS, and is released at <http://www.ccs.org.cn>. Your comments or suggestions are welcomed and may be sent to our email addressed mp@ccs.org.cn.

Historical versions and release date : P-01(201510) October 20,2015

P-01(201610) October 28,2016

P-01(201907) July 26,2019

P-01(202102) February 26,2021

Main changes:

1 This guideline is updated in accordance with IACS rec 151 (Rev. 1 Nov 2020)

2 Correct errors in printing

CONTENTS

1 Application 4

2 Normative references 4

3 Terms and definitions 4

4 Plans and documents 5

5 Materials and components 6

6 Evaluation of welding procedures..... 6

7 Design and technical requirements 6

8 Selection of typical samples 8

9 Type test 9

10 Unit/batch inspection..... 20

PUMPS

1 Application

1.1 This Guideline applies to centrifugal pumps, regenerating pumps, axial flow pumps, mixed-flow pumps, screw pumps, gear pumps, reciprocating pumps, etc. For other types of pumps, reference may be made to in This Guideline.

1.2 The requirements of G3.6 Rev.6 are to be uniformly implemented by IACS Societies for the following pumps:

- (1) when an application for testing is dated on or after 1 January 2017; and
- (2) which are installed in new ships for which the date of contract for construction is on or after 1 January 2017.

2 Normative references

2.1 The approval and inspection in This Guideline are to be based on the following documents:

- (1) CCS Rules for Classification of Sea-Going Steel Ships;
- (2) CCS Rules for Materials and Welding;
- (3) IACS UR_G3 (Rev.6 2016).
- (4) IACS Rec 151(July 2017).
- (5) IACS Rec 151 (Rev.1 Nov 2020).

3 Terms and definitions

3.1 For definitions of terms such as products inspection, approval, type test, sample and unit/batch inspection, refer to the relevant requirements of CCS Rules for Classification of Sea-Going Steel Ships.

3.2 Displacement pump means screw pump, gear pump and reciprocating pump.

3.3 Design pressure is to be taken as the maximum pressure on the characteristic curves for centrifugal pumps and regenerating pumps, and as the full backflow pressure of the safety valve

for displacement pumps.

3.4 Cargo pump^① means crude/product oil pump, liquid chemical pump, low-temperature liquefied gas pump, etc.

4 Plans and documents

The applicant is to submit an approval application together with the following plans and documents according to the requirements of this paragraph.

4.1 The following plans and documents are to be submitted to CCS for approval:

- (1) Main performance specifications (covering the entire series for which approval is sought: capacity, pressure, speed, shaft power, cavitation performance, medium, etc. In the case of pump assemblies, type and parameters of associated electrical motors are also to be included);
- (2) General assembly (sectional drawing);
- (3) Bearing and seal construction and arrangement (if reflected in the general assembly drawing, submission is not necessary);
- (4) List of physical and chemical properties of important components;
- (5) Drawing of important components, such as casing, cover, screw, gear, impeller, shaft, liner, etc.;
- (6) Type test programme.

4.2 The following plans and documents are to be submitted to CCS for information:

- (1) Operation instructions for the products;
 - (2) Main technological documents, such as heat treatment procedure of parts, welding procedure for casing and if necessary, casting procedure;
-

(3) Specimens of product nameplates and manufacturer's certificate, etc.

5 Materials and components

5.1 Materials and components are to comply with relevant requirements of CCS Rules. Materials and components include casing, cover, safety valve casing, screw, gear, impeller, shaft, liner, etc.

5.2 100% of casings, covers, safety valves and other pressure parts are to be subjected to hydraulic pressure test prior to assembly, and the hydraulic pressure test report is to be reviewed and confirmed by CCS Surveyor or the test is to be witnessed by CCS Surveyor.

5.3 If the important components referred to in 5.1 are purchased, the applicant is to establish perfect means to control subcontractors for ensuring the quality of such parts.

5.4 If the pressure parts such as casings, covers, safety valve casing, etc. are made of castings or forgings, The physical and chemical property test report of the factory should be provided.

6 Evaluation of welding procedures

6.1 Where the main components and parts listed in 5.1 above are of welded construction, the welding procedures are to be evaluated and approved according to the relevant requirements of CCS Rules for Materials and Welding.

7 Design and technical requirements

7.1 Marine ambient conditions

Marine pumps are to operate normally with the ship having a 15 °heel, or 22.5 °roll, or 5 °trim or 7.5 °pitch. Emergency fire pumps and pumps associated with emergency generating sets are to operate normally with the ship having both heel and roll being 22.5 °or trim and pitch being 10 °.

7.2 Materials

7.2.1 Materials of important components of marine pumps are to be selected for types, temperatures and pressures of medium to be conveyed. In the case of conveying dangerous chemicals, the manufacturer is to provide sufficient evidence for compliance of the material selected with operational requirements.

7.2.2 Casings of thermal oil pump or other pump conveying high-temperature medium (including safety valves) are to be of steel or equivalent ductile material and suitable for related operating

temperatures.

7.2.3 If fuel oil pump casings (including safety valves) are of gray cast iron, the maximum working pressure is not to exceed 0.7MPa and the maximum operating temperature not to exceed 60°C.

7.2.4 All elastomeric components in the fuel oil system (e.g. diaphragms) should be made of fluoro-rubber or other material suitable for use with marine fuels according to MSC.1/Circ.1321.

7.2.5 In the case of conveying a low-temperature medium, material of casings (including safety valves) is to be selected according to the relevant requirements of CCS Rules for Materials and Welding.

7.2.6 If the pump is fitted on the piping connecting with cargo tank onboard the ship carrying liquefied gases in bulk, the melting point of casing material is not to be lower than 925 °C (IACS UR_G3 (Rev.6 2016)).

7.3 Vibration

When operating in rated conditions, maximum vibration severity V_{rms} (in mm/s) of marine pumps is to comply with the following requirements:

- (1) for centrifugal pumps and regenerating pumps, $V_{rms} < 7.1$;
- (2) in the case of displacement pumps, $V_{rms} < 11.2$ for vertical ones, and $V_{rms} < 7.1$ for horizontal ones.

7.4 Temperature of bearings

The actual working temperature of bearings is not to exceed the maximum value specified by the manufacturer, in general, the maximum surface temperature of bearings is not to exceed 75°C and the temperature rise is not to exceed 35°C during operation.

7.5 Pressure parts

All pressure parts including casings, covers and safety valves are to be hydraulically tested to 1.5 times the design pressure for not less than 5 min prior to assembly.

7.6 Safety valves

7.6.1 In general, all displacement pumps are to be fitted with a safety valve. Each safety valve is to be so arranged as to discharge back to the suction side of the pump.

7.6.2 The opening pressure of the safety valve is to be 1.1~1.15 times the rated working pressure.

7.6.3 When the safety valve is in a full backflow condition, the discharge pressure of the pump (the full backflow pressure of the safety valve) is not to exceed 1.5 times the rated discharge pressure; when the rated discharge pressure is not more than 0.5 MPa, the discharge pressure is not to exceed the rated discharge pressure plus 0.25 MPa.

7.6.4 When the safety valve returns to the closed condition from the full backflow condition, the pump capacity at rated pressure point is not to be less than that before the safety valve being opened.

7.7 Self-priming performance

The marine pumps intended for emergency fire pumps or power bilge pumps are to be of self-priming type. The self-priming height of the intended emergency fire pumps is not to be less than 4.5m.

7.8 The fire pumps and emergency fire pumps are also to meet the relevant requirements of Chapter II-2 in SOLAS and Chapter 12 in FSS Code.

7.9 The pumps intended for conveying liquefied dangerous chemical medium are also to meet the relevant requirements of CCS Rules for Construction and Equipment of Ships Carrying Dangerous Chemicals in Bulk and IBC Code.

7.10 The pumps intended for conveying liquefied gas medium are also to meet the relevant requirements of CCS Rules for Construction and Equipment of Ships Carrying Liquefied Gases in Bulk and IGC Code.

8 Selection of typical samples

8.1 When applying for approval at the first time, the selected sample pumps are to be typical products capable of representing or covering the products or product series for which approval is sought, in respect of performance, characteristics, manufacturing quality.

8.2 When renewing the approval, one or several types which are the most representative or the most demanded in market may be selected as samples.

8.3 For pumps intended for conveying low-temperature liquefied gas medium, type test is to be carried out for each type and specification in accordance with the requirements of 9 of This Guideline. In lieu of prototype testing, satisfactory in-service experience, of an existing pump design approved by a Society submitted by the manufacturer may be considered (IACS UR_G3 (Rev.6 2016)).

9 Type test

9.1 Test items

9.1.1 Generally, type test items are to include:

- (1) inspection of raw materials of pressure parts;
- (2) hydraulic strength test of main pressure parts;
- (3) operation test;
- (4) full performance test;
- (5) safety valve test (for displacement pumps fitted with safety valves only);
- (6) cavitation test (if cavitation performance is required);
- (7) self-priming performance test (for pumps required for self-priming capability only, such as self-priming centrifugal pumps intended for emergency fire use);
- (8) self-induced vibration test;
- (9) fixed-inclination test (for pumps required for self-priming capability only, such as emergency fire pump, etc.);
- (10) Endurance test of low sulfur fuel pump(Optional inspection items);
- (11) dismantling after test.

9.1.2 Exemption from test items

- (1) Approval for the first time

Normally all test items applicable in 9.1.1 above are to be carried out when the applicant applies for approval at the first time. The manufacturer may apply for exemption from some of the test items in writing, and CCS Surveyor will consider the application according to the manufacturer's production, history of production and usage record of his products and will fax the manufacturer's written application together with comments to the Classed Newbuildings Department/Product Management Department of the Headquarters, and can grant an exemption from some test items only upon approval by the Classed Newbuildings Department/Product Management Department, provided that the following conditions are met:

- ① the applicant is to be able to provide a test report of corresponding test items issued by an authoritative technical organization (e.g. General Administration of Quality Supervision, or a national defense laboratory) recently;
- ② the applicant is to be able to provide a test report of corresponding test items signed by an IACS member society recently;

(2) Re-approval at renewal of approval certificate

If there is no change to design and if there is no change to technical requirements of CCS Rules for Classification of Sea-Going Steel Ships for the type of products, the type test may be omitted. However, CCS still reserves the right to require type test again.

9.2 Test requirements

9.2.1 Test location

CCS Surveyor is to check the manufacturer's test laboratory/test bench used as approval test location and confirm compliance with the requirements of 9.2.2, 9.2.3 and 9.2.4 below. Otherwise, all tests are to be carried out at certification and test organizations recognized by CCS.

9.2.2 Measuring instruments

Measuring instruments used in the tests are to be calibrated and hold with valid calibration certificates, and the accuracy of test instruments is to meet the test requirements.

9.2.3 Test medium

Unless special cases provided otherwise, tests are generally to be carried out with the following

medium:

- (1) Petroleum distillate is generally used in three-screw pumps and gear pumps as test medium. The viscosity and temperature characteristic of the test oil is to be measured as required or provided by the test oil supplier.
- (2) Clean fresh water is generally used in single-screw pumps, centrifugal pumps and regenerating pumps as test medium.
- (3) Petroleum distillate or clean fresh water is used in double-screw pumps, reciprocating pumps and other pumps, as appropriate.

9.2.4 Test apparatus

Typical arrangement of test apparatus is given in Appendix A.

9.2.5 Measurement of test parameters

(1) Capacity measurement

Pump capacity may be measured by the turbine flowmeter, tube flowmeter, electromagnetic flowmeter, gravimetric method or volumetric method.

(2) Pressure measurement

- ① Pump pressure is the converted inlet pressure or outlet pressure on the reference surface, and the full pressure is the difference between inlet pressure and outlet pressure. The reference surface of horizontal pumps is the horizontal surface with centerline of rotor axis; the reference surface of vertical pumps is the horizontal surface with suction centerline.
- ② The pressure may be measured by liquid column manometer, spring pressure gauge, piston pressure gauge or other types of pressure gauge.

(3) Speed measurement

Speed may be measured directly by the digital photoelectric tachometer.

(4) Shaft power measurement

Shaft power is to be obtained by:

- ① measuring the torque and speed of the shaft by the dynamometer, and then to obtain the value through calculation; or
- ② measuring the output power of drive motor by an electrotechnical instrument, and then multiplying the measured value by efficiency of motor.

9.3 Test methods

9.3.1 Inspection of raw materials of pressure parts

The pump factory shall submit the quality document of parts such as casings, covers, safety valves, etc. to the CCS surveyor for review.

For the pumps intended to use for medium with the temperature below -55°C , its raw material is to be tested at its minimum design temperature.

9.3.2 Hydraulic strength tests of main pressure parts

(1) Scope

Main pressure parts include casings, covers and safety valves (if any), which may generally be subject to a hydraulic test either separately or as an assembled unit; for pumps driven by compressed air or steam, or fitted with casing steam-heating apparatus, the hydraulic test is also to be carried out at air/steam sides.

(2) Test pressure

The hydraulic test pressures of pressure parts for different pump types are as follows:

- ① For centrifugal pumps and regenerating pumps, test pressure is to be 1.5 times the design pressure;
- ② For screw pumps, gear pumps and reciprocating pumps, test pressure is to be 1.5 times the design pressure or the design pressure plus 7 MPa (whichever is the lesser), but in no case less than 0.6 MPa;
- ③ For pumps driven by compressed air or high-pressure steam, or fitted with steam-heating apparatus, the hydraulic test pressure at air/steam sides is to be 1.5 times the maximum

working pressure of compressed air or steam.

(3) Evaluation of test results

The surface of test pieces is to be clean and have no coating, free from leakage after testing for at least 5 min.

9.3.3 Operation test

- (1) The operation test is mainly to examine the assembling quality of pumps and pumping sets. Attention is to be given to whether the temperature and temperature rise of pump bearings and shaft seals are within the required limits and whether leakage of shaft seals is in compliance with the relevant requirements and whether any abnormal vibration or noise occurs.

Temperature of bearings and leakage of mechanical seals are to be as follows:

- ① the surface temperature and temperature rise of bearings are not to be more than as required in 7.4 of This Guideline;
 - ② unless the special requirements, the leakage of mechanical seals is not to exceed 10 mL/h and that of packing seals not to exceed 6 mL/min.
- (2) The pressure of the pump in testing is to increase gradually to the required pressure at rated speed and the pump is to operate at the rated pressure point for a sufficient duration to ensure the mechanical sealing conditions and temperature rise to comply with the relevant requirements.
- (3) If any abnormal vibration, noise or excessive bearing temperature occurs, the test is to be stopped immediately and can be continued only after failure causes are identified and eliminated.

9.3.4 Full performance test

- (1) Full performance test is to determine the relationship between pressure (lift), capacity, shaft power and efficiency of the pump at rated speed for verifying the correctness of pressure – capacity curve, pressure – shaft power curve and other characteristic curves submitted by the manufacturer (applicant for approval). The full performance test is to be carried out upon satisfactory operation test.

(2) Test speed is to be close to the required one so far as possible, with certain allowable deviation:

- ① for displacement pumps, actual test speed may be within $\pm 5\%$ of rated speed;
- ② for centrifugal pumps, mixed-flow pumps and axial flow pumps, etc., the actual test speed range is to be as follows:

when measuring capacity and lift, the actual test speed is to be within 50% ~ 120% of rated speed;

when measuring efficiency of the pump, the actual test speed is to be within $\pm 20\%$ of rated speed.

(3) Selection of operating condition (measuring points):

- ① for displacement pumps, the test is to start from zero pressure point (or close to zero pressure) when the outlet pressure control valve is fully opened. Generally at least six pressure points are selected including zero pressure point and required pressure point, evenly distributed within the required pressure range;
- ② for centrifugal pumps, the test is to start from zero capacity point (when the outlet pressure control valve is fully closed) to 120% of rated capacity. At least seven pressure points are selected as measuring points, evenly distributed on the entire characteristic curves; if it is not practical to select points according to capacity (e.g. the capacity is measured by volumetric method), points may be selected according to pressure, but to be evenly distributed on the entire characteristic curves;
- ③ for mixed-flow pumps, axial flow pumps and regenerating pumps, the test is to start with the outlet pressure control valve being fully opened and end when 85% of the rated minimum capacity is reached. At least seven pressure points are selected as measuring points and evenly distributed on the entire characteristic curves; if it is not practical to select points according to capacity (e.g. the capacity is measured by volumetric method), points may be selected according to pressure, but to be evenly distributed on the entire characteristic curves;
- ④ if the design pressure (capacity) range of pumps is narrow, the number of measuring points may be reduced as appropriate;

- ⑤ each measuring point is to be stable for sufficient time in order to reach consistence and expected accuracy.

(4) Capacity test (performance test at rated pressure) of liquefied gas cargo pumps

The capacity test (performance test at rated pressure) is to be carried out for the pumps intended for conveying low-temperature liquefied gas medium in accordance with the following requirements (IACS UR_G3 (Rev.6 2016)):

- ① for submerged pumps (both the prime motor and pump are submerged in medium), the operation test is to be carried out by adoption of low-temperature medium designed for the pumps or other medium with temperature lower than the design value;
- ② for deep well pump with long shaft (only the pump submerged in medium, and driven by prime motor through one or several associated long shafts), water could be used as medium for the operation test at its rated working point. However, an additional operation test is to be carried out under the minimum design temperature at random working point to verify that the bearing clearance, friction ring and sealing device are reliable. It is unnecessary for such additional low-temperature operation test to be carried out as the driving shaft in whole length is fitted, but its length is ensured to be sufficient to install at least one bearing with sealing device.

(5) Test data

The following data are to be taken at each testing point:

- ① outlet pressure;
- ② inlet pressure;
- ③ capacity;
- ④ ambient temperature (measured only once if temperature variation is not obvious);
- ⑤ medium temperature (to be taken at each measuring point);
- ⑥ temperature of bearings (for assessing normal operating condition of pumps only, and measured only once at each measuring point);
- ⑦ speed;

- ⑧ shaft power.

(6) Conversion of test data

When the deviation of test speed from required one falls within the range as specified in 9.3.4(2), the test data may be converted into related data for rated speed/viscosity according to the following methods.

- ① Displacement pumps

For the displacement pump, if its speed and viscosity of medium do not meet the requirements due to test conditions, the manufacturer is to provide the formula so as to convert the actual measured data to the value at rated speed and required viscosity. Such formula is to be marked in the test report.

- ② Centrifugal pumps, axial flow pumps and mixed-flow pumps

When the difference between test speed and rated speed is within the range mentioned in 9.3.4(2), the test data may be converted to the corresponding values at rated speed in accordance with the following formulae:

$$Q_{in} = Q_i \frac{n}{n_i} \dots\dots\dots(1)$$

$$H_{in} = H_i \left(\frac{n}{n_i} \right)^2 \dots\dots\dots(2)$$

$$Pa_{in} = Pa_i \left(\frac{n}{n_i} \right)^3 \dots\dots\dots(3)$$

where: Q_{in} – capacity at measuring point at rated speed, in m³/h;

Q_i – capacity measured at measuring point, in m³/h;

Q_0 – measured capacity at zero pressure point, in m³/h; with the inlet and outlet control valves being fully opened and measured inlet and outlet pressures being approximately zero, the capacity at rated speed may be converted according to the positive ratio of actual speed to rated speed;

H_{in} – lift at measuring point at rated speed, in m;

H_i – lift measured at measuring point, in m;

Pa_{in} – shaft power at measuring point at rated speed, in kW;

Pa_i – shaft power measured at measuring point, in kW;

n/n_i – rated speed/measured speed, in r/min.

(7) Analysis of test data

Measured data are to be compared with characteristic curves submitted by the manufacturer (the applicant for approval). The measured data are to be basically consistent with such characteristic curves within the allowable operating range given by the manufacturer (the applicant for approval) and the tolerances for rated conditions are to be as required below:

- ① capacity tolerance of displacement pumps is not to exceed that given in Table 9.3.4(1);

Capacity Tolerance of Displacement Pumps **Table 9.3.4(1)**

Rated capacity range m ³ /h	Capacity tolerance %
≤ 0.1	-10 ~ +20
> 0.1 ~ 10	+10
> 10	-5~+10

- ② lift tolerance of centrifugal pumps and regenerating pumps is not to exceed ±10%;

- ③ shaft power tolerance is not to exceed that given in Table 9.3.4(2).

Shaft Power Tolerance **Table 9.3.4(2)**

Rated shaft power range kW	Shaft power tolerance %
≤ 5	+25
> 5 ~ 10	+20
> 10 ~ 50	+15
> 50	+10

9.3.5 Safety valve test

- (1) All displacement pumps designed to be fitted with safety valves are to be subjected to safety valve test.
- (2) The opening pressure of the safety valve is first to be measured, which is to be 1.1 ~ 1.15 times the rated discharge pressure.
- (3) The outlet control valve is then to be gradually closed until fully closed to measure the total backflow pressure of the safety valve; the total backflow pressure of the safety valve is not to exceed 1.5 times the rated discharge pressure; when the rated discharge pressure is less or equal to 0.5 MPa, the total backflow pressure of the safety valve is not to exceed the rated discharge pressure plus 0.25 MPa.
- (4) When the outlet control valve is reopened and the condition of the pump returns from full backflow of the safety valve to rated pressure point, the capacity is not to be less than that measured at the point during full performance test.

9.3.6 Cavitation test

The cavitation test may be carried out by either of the following test methods:

- (1) when the cavitation parameter in performance data submitted by the manufacturer is the allowable suction vacuum lift H_s , the inlet control valve may be closed gradually at the required point to reach that allowable suction vacuum lift H_s at the inlet. The pump capacity may be measured only when the difference between outlet and inlet pressures remains unchanged. When the capacity reduction is less than 3% of that at the required point during the performance test, H_s provided by the manufacturer is acceptable;
- (2) when cavitation parameter in performance data submitted by the manufacturer is the necessary net positive suction head (NPSH)_r, the critical net positive suction head (NPSH)_c is to be measured by testing and compared with that necessary net positive suction head (NPSH)_r. In case of $(NPSH)_r \geq (NPSH)_c + 0.3 \text{ mH}_2\text{O}$, the necessary net positive suction head (NPSH)_r provided by the manufacturer is acceptable.

9.3.7 Self-priming performance test

- (1) The medium in the test pipeline is to be evacuated by practical and reliable means before the test.

- (2) During the test, the vertical height of inlet piping is not to be less than the self-priming height given by the manufacturer, the diameter of piping connected in way of inlet of pump and the distance from the inlet of pump to liquid surface are to be recorded in the test report.
- (3) During the test, the speed allowance is $\pm 5\%$, and the test is to be repeated for at least three times, and the time from starting to the moment when water discharge commences is to be measured in each test cycle, which is to be not more than the time given by the manufacturer in approved technical documents.

9.3.8 Self-induced vibration test

- (1) Self-induced vibration test may be carried out in the rated operating condition in conjunction with the operation test or the full performance test.
- (2) Self-induced vibration test points may be selected as follows:
 - ① the inlet bearing end cover and outlet flange of the pump may be selected as main measuring points;
 - ② the pump pedestal or pump case may be selected as an auxiliary measuring point;
 - ③ the vibration severity V_{rms} (in mm/s) in directions X, Y and Z are to be measured at each measuring point.
- (3) The maximum vibration severity V_{rms} measured is to comply with the requirements of 7.3 of This Guideline.

9.3.9 Fixed inclination test (only applicable to pumps required for self-priming performance, such as emergency fire pump, etc.)

- (1) The test is to be carried out at the required point for at least 60 min.
- (2) One pump is to be selected for each pump type, for which approval is sought, and tested to verify the compliance of the pump design with the requirements for service in conditions of inclination and heeling of the ship.
- (3) The inclination angle in the test is to be as follows:
 - ① the shaft axis is at an angle of 20° to the horizontal plane for horizontal pumps, and 25°

for pumps to be used as emergency fire pumps;

- ② the shaft axis is at an angle of 70 ° to the horizontal plane for vertical pumps, and 65 ° for pumps to be used as emergency fire pumps.

9.3.10 Endurance test of low sulfur fuel pump(Optional inspection items)

- (1) A running test should be carried out with a minimum or lower viscosity fuel oil with a sulphur content of 0.10 % m/m or less specified in ISO 8217:2017 Specifications for Marine Fuels; recommended fuel oil viscosity value for the test should be 2.0 cSt at the fuel pump. If the low sulfur fuel can not be obtained in the test, the diesel fuel can be used instead, and the marine diesel oil should be heated so that the viscosity is close to the viscosity of the low sulfur fuel.
- (2) The lubricity of fuel oil for running test should be less than 520 μm as determined by a high-frequency reciprocating rig test according to ISO 12156-1:2018.
- (3) The running test should be conducted for a minimum of 250 hours for pumps for both continuous and non-continuous operation and at a discharge pressure equal to the nominal pump pressure rating.

9.3.11 Dismantling after test

Each pump which has been subjected to type test is to be dismantled to examine the wear of operating components, the surface of which is to be free from obvious locking together or excessive wear. The structural dimensions and fit clearance of components are to be within required limits.

10 Unit/batch inspection

CCS inspection may be requested only for those pumps which have been satisfactorily inspected/tested by the manufacturer and are ready for delivery.

10.1 The unit/batch inspection items for manufacturers with CCS type approval B are as follows:

10.1.1 Tests are to be carried out according to the approved inspection plan (related provisions in quality control plans), including at least the performance test at required points (operation test), self-priming performance test (if required), safety valve test (if any) and cavitation performance test (if cavitation performance required).

10.1.2 The above tests may be carried out by the manufacturer independently and a complete test report is to be submitted to the Surveyor for review.

10.1.3 At least 3% or one unit is to be selected randomly from each batch/for each structural type and re-tested by the Surveyor according to the above test items in 10.1.1 or the test of which is to be witnessed at the manufacturer.

10.1.4 The raw material quality certificates of important components and the hydraulic strength test records of pressure parts for each unit/batch are to be submitted to CCS Surveyor for review when applying for unit/batch inspection.

10.1.5 The pump factory shall submit the quality document of parts such as casings, covers, safety valves, etc. to the CCS surveyor for review.

10.1.6 Special requirements of cargo pumps intended for conveying liquefied gases (IACS UR_G3 (Rev.6 2016))

- (1) water pressure test of casing and performance test at rated pressure for each pump are to be witnessed by CCS surveyor at site;
- (2) for submerged pumps (both the prime motor and pump are submerged in medium), the performance test at rated pressure is to be carried out by adoption of low-temperature medium designed for the pumps or other medium with temperature lower than the design value; for the shaft driven deep well pumps, the capacity test may be carried out with water.

10.2 Unit/batch inspection for manufacturers with CCS type approval A

10.2.1 The inspection is basically to review reports and all test items are to be completed by the manufacturer independently. The inspection application is to be submitted before product delivery, together with reports/records/documents covering all test/inspection items specified in 10.1.1, 10.1.4 and 10.1.5 of This Guideline for review by CCS Surveyor.

10.2.2 Periodical audits are to be requested in time by manufacturers with CCS type approval A according to the requirements in Section 4, Chapter 3, PART ONE of CCS Rules for Classification of Sea-Going Steel Ships

10.3 Unit/batch inspection for manufacturers without CCS approval

10.3.1 The inspections are to include drawing examination and type test.

10.3.2 Plan approval

Drawings/technical documents are to be prepared by the manufacturer according to 4.1 and 4.2 of This Guideline and submitted to CCS for approval/information.

10.3.3 Type test

For pumps to be inspected, at least one unit is to be selected randomly for each type and tested for all type test items required in 9 of This Guideline.

10.3.4 Pumps, which have not been selected as samples, are to be inspected and tested at least according to 10.1 of This Guideline.

Appendix A Arrangement of Test Apparatus

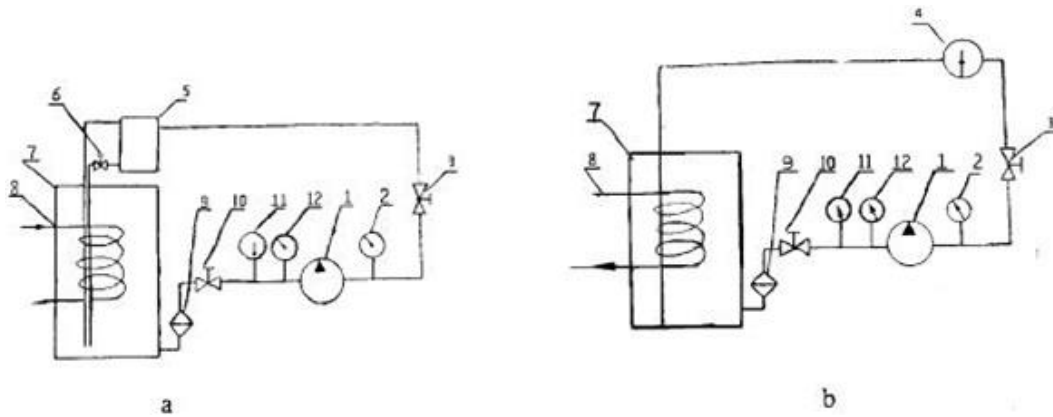

Figure 1 Test Apparatus of Screw Pumps and Gear Pumps

1 – Test pump; 2 – Outlet pressure gauge; 3 – Outlet pressure control valve; 4 – Flowmeter; 5 – Metering container; 6 – Valve; 7 – Storage tank; 8 – Heat exchanger; 9 – Filter; 10 – Inlet pressure control valve; 11 – Temperature meter; 12 – Vacuum gauge

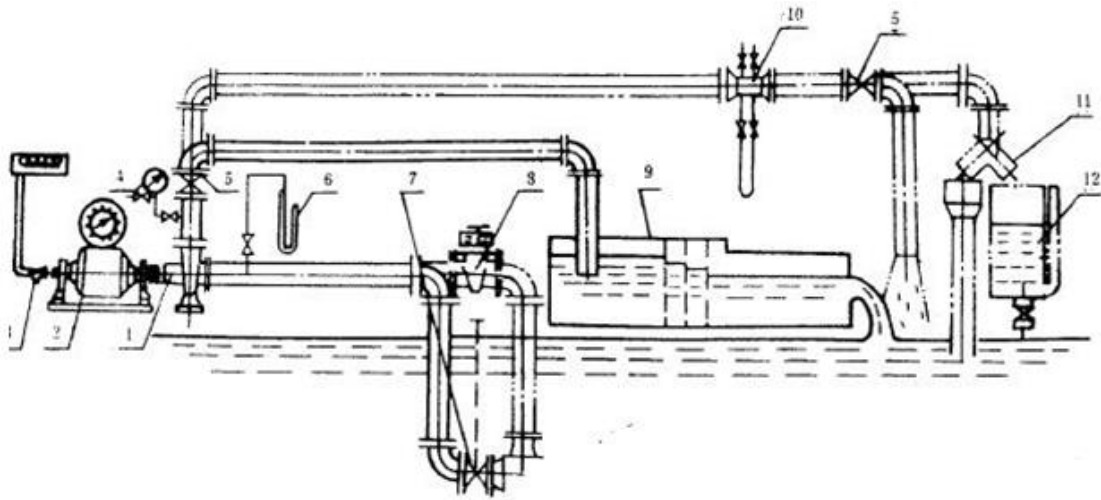

Figure 2 Open Test Basin for Centrifugal Pumps and Regenerating Pumps

1 – Test pump; 2 – Dynamometer; 3 – Velometer; 4 – Manometer; 5 – Flow control valve; 6 – Vacuum gauge; 7 – Inlet throttle; 8 – Water seal throttle; 9 – Water weir; 10 – Flowmeter; 11 – Reverser; 12 – Measuring vessel

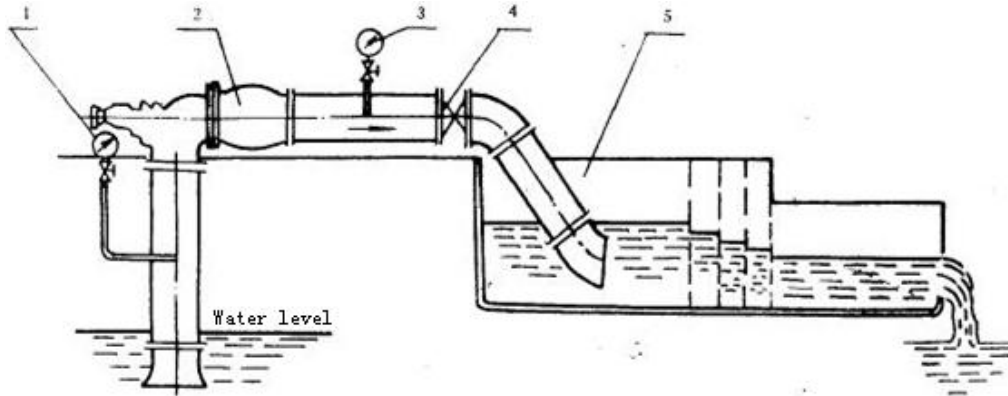

Figure 3 Open Test Basin for Centrifugal Pumps and Regenerating Pumps

1 – Vacuum gauge; 2 – Test pump; 3 – Manometer; 4 – Flow control valve; 5 – Water weir

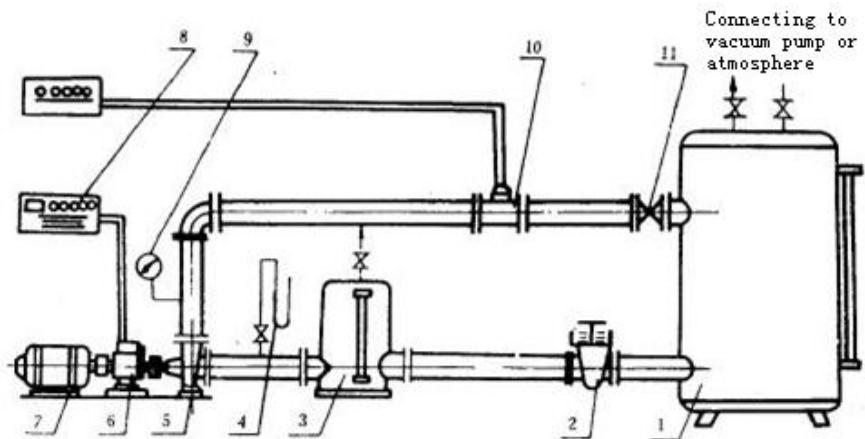

Figure 4 Closed-Circuit Test Apparatus for Centrifugal Pumps and Regenerating Pumps

1 – Cavitation tank; 2 – Water-seal gate valve; 3 – Stabilizer; 4 – Vacuum gauge; 5 – Test pump; 6 – Torque sensor; 7 – Motor; 8 – Torque tachometer; 9 – Manometer; 10 – Flowmeter; 11 – Flow control valve