



I-04

SATELLITE EMERGENCY POSITION-INDICATING RADIO BEACON

Issued date: Nov 15, 2021

Foreword

CCS Product Inspection and Testing Guideline (hereinafter referred to as this Guideline) contains the technical requirements, inspection and testing criteria related to classification and statutory survey of marine products to be applied for CCS approval/inspection.

This Guideline frees the users to adopt other test methods and requirements which are equivalent to or are stricter than this Guideline.

This Guideline is published and updated by CCS, and is released at <http://www.ccs.org.cn>. Your comments or suggestions are welcomed and may be sent to our email addressed mp@ccs.org.cn.

Historical version and release date: I-04(201510) October 20, 2015

Main change: According to the requirements of msc.471 (101) which has come into effect recently, it is modified.

Table of Contents

1 Scope of Application.....	4
2 Normative References.....	4
3 Terms and Definitions.....	5
4 Drawings and Documents.....	6
5 Technical Requirements of Design.....	10
6 Raw Material and Parts.....	25
7 Type Approval and Unit/Batch Test.....	25

SATELLITE EMERGENCY POSITION-INDICATING RADIO BEACON

1 Scope of Application

This Guideline applies to type approval and unit/batch inspection of satellite emergency position-indicating radio beacon (406MHz EPIRB).

Special attention should be paid to:

According to msc.471 (101), the 406mhz EPIRB installed on or after July 1, 2022 shall meet the performance standards and type approval standards no less than those specified in the annex of the resolution; The 406mhz EPIRB installed before July 1, 2022 shall conform to the performance standard specified in the annex of resolution a.810 (19) amended by resolution msc.56 (66) and msc.120 (74), and the type approval standard shall not be lower than the type approval standard specified in resolution a.696 (17).

At present, it belongs to the transitional stage of the two groups of conventions. We should pay special attention to the conventions on which customers apply for recognition.

Because the IEC standard used in conjunction with msc.471 (101) resolution has not yet come into effect, this revision of this guide mainly indicates the changes in the requirements of msc.471 (101), and does not provide the requirements for type test. Once the IEC standard comes into effect, we will launch a new version to meet the relevant requirements as soon as possible. Please pay special attention to it.

2 Normative References

IMO A.810 (19): *Performance Standards for Float-free Satellite Emergency Position Indicating Radio Beacons (EPIRB) Operating on 406 MHz*

IMSC.56(66): *Adoption of Amendments to Performance Standards for Float-free Satellite Emergency Position Indicating Radio Beacons (EPIRB) Operating on 406 MHz*

IMO Resolution A.662(16): *Performance Standards for Float-free Release and Activation Arrangements for Emergency Radio Equipment*

IMO Resolution A.694(17): *General Requirements for Shipborne Radio Equipment Forming Part of the Global Maritime Distress and Safety System (GMDSS) and for Electronic Navigational Aids*

Msc.471 (101) resolution "Performance standards for float-free emergency 371 position-indicating radio beacons (EPIRBs) operating on 406 MHz"

IEC 61097-2:2008: *Global Maritime Distress and Safety System (GMDSS) - Part 2: COSPAS-SARSAT EPIRB - Satellite Emergency Position Indicating Radio Beacon Operating on 406 MHz - Operational and Performance Requirements, Methods of Testing and Required Test Results*

IEC 60945:2002: *Maritime Navigation and Radiocommunication Equipment and Systems - General Requirements - Methods of Testing and Required Test Results;*

C/S T.001-2017: *Specifications for COSPAS-SARSAT 406 MHz Distress Beacon*

C/S T.007-2017: *Type Approval Standards for COSPAS-SARSAT 406 MHz Distress Beacon*

GD 22-2015: *CCS Guidelines for Type Approval Test of Electric and Electronic Products.*

GB 14391-2009 *Technical Requirements for Satellite Emergency Position-indicating Radio Beacons*

2.2 The latest version of effective document shall be adopted in case of modifications on above-mentioned conventions, rules, performance recommendations and test standards.

3 Terms and Definitions

Terms and definitions specified in above-mentioned approval and survey basis apply to this Guideline. Considering convenience of compilation and application, the following definitions are directly referenced or complemented in this Guideline.

3.1 EPIRB: Satellite Emergency Position-Indicating Radio Beacons;

3.2 COSPAS-SARSAT: Global Satellite Search and Rescue System;

3.3 GMDSS: Global Maritime Distress and Safety System;

3.4 BDS: BeiDou Navigation Satellite System;

3.5 GPS: Global Positioning System;

3.6 GLONASS: Global Navigation Satellite System;

3.7 GALILEO: Galileo satellite navigation system;

3.8 UTC: Universal Time Coordinated;

3.9 PVT: Position Velocity Time;

3.10 GNSS: Global Navigation Satellite System;

3.11 Dilution of Precision (DOP): factor indicating the contribution of the geometrical position of navigation satellite to errors. The error of satellite navigation system is the product of ranging error and dilution of precision, including geometric dilution of precision (GDOP), position dilution of precision (PDOP), horizontal dilution of precision (HDOP), vertical dilution of precision (VDOP) and time dilution of precision (TDOP).

4 Drawings and Documents

4.1 The following drawings and documents shall be submitted to CCS for approval:

- (1) Structure drawings and outline drawings of complete equipment.
- (2) Electrical schematic diagram, wiring diagram and electrical functional block diagram.
- (3) Technical conditions of product

Technical conditions of product shall clearly define the general performance and general design requirements of product, at least including the following items:

- ① Regulations on ambient conditions of product.
- ② Constituent parts of product, main purchased parts and sources.
- ③ Detailed description for product function and performance index.
- ④ Acceptance conditions of complete equipment.

(6) At least, software shall include the following items:

- ① Description of major software module and software version number.
- ② Software maintenance and update description.

(7) Product operation manual: the manual shall be in Chinese and English version or only in English version, and shall at least include the following contents:

- 1) COSPAS-SARSAT system overview;
- 2) Complete description of EPIRB operation and self-testing;
- 3) Warnings and suggestions for false alarm prevention;
- 4) Description for importance statement of approval, registration, registration update and correct registration;

- 5) Battery information, including replacement instruction, battery type and safety information related to battery usage and disposal;
- 6) Introduction for battery replacement after any application of EPIRB (excepting self-testing);
- 7) Minimum service life, operating and storage temperature;
- 8) Purpose of sling: It is not allowed to fix EPIRB on the ship with a sling;
- 9) It is not suggest to use EPIRB in life float or under similar coverings or sheds;
- 10) Maintenance and/or operation of any hydrostatic release unit and relevant component that may be aged, such as release lever;
- 11) Manufacturer's suggestions (if any) on periodic function test and battery replacement;
- 12) Suggestion on keeping the initial packing of EPIRB because it may be required when EPIRB is posted for maintenance. According to relevant requirements of the United Nations, packaging standards shall be met and labels shall be set if some batteries are transported as hazardous articles;
- 13) Instructions involving safe transport or loading of EPIRB or their sources accessible for users;
- 14) Warranty information;
- 15) Warning that EPIRB shall not run under non-emergency condition;
- 16) Warning that EPIRB shall not be installed near high-intensity magnetic field that may activate EPIRB;
- 17) Suggestion for high installation of EPIRB, especially in small ship, which will be in favor of operation of self-floating hydrostatic release unit for capsized ship but not sunken ship;
- 18) Suggestion for minimizing the self-testing to ensure sufficient electric energy for EPIRB running;
- 19) Limiting the Warning from self-testing within 5 minutes before integral point if 121.5 MHz signals are sent by EPIRB during self-testing.
- 20) If applicable, the list of external GNSS receiver used by EPIRB to receive the input from external navigation system, and the introductions concerning connection and setting of external equipment;
- 21) Information used for internal integrated GNSS receiver equipment of EPIRB or interfaced with external GNSS receiver equipment and guiding the user to achieve the optimal self-positioning performance, including warning not to impeding the sky view of GNSS antenna;

22) Clarification of necessity for reporting false alarm information from EPIRB to the nearest search and rescue agency through the most convenient way. Information to be reported includes EPIRB 15-Hex ID, date, time, duration, activation causes and shutdown position.

23) ensuring the installation of EPIRB satisfies the following requirements:

EPIRB shall be installed in the accessible place;

EPIRB shall be installed through the way satisfying the requirements of the standard (A.694(17)/2);

The local manual activation function shall be configured; remote start in deck bridge can be also adopted if the equipment is installed in the self-floating unit (A.810(19)/A.2.6.1);

Before sinking in 4-m water at any angle, the equipment shall be released, achieving self-floating (A.810(19)/A.2.6.3);

The installation way, preventing the equipment from being hindered by structure of sunken ship after release, shall be adopted (A.662(16)/2.8).

(8) Equipment labels

Labels shall be set on EPIRB and its enclosure (if any) as required.

a) Brief operation instructions shall be in English at least, achieving manual activation, closing and self-testing;

b) Warning that EPIRB shall not run under non-emergency condition shall be labeled;

c) Type name and category specified by manufacturer, battery type and warranty period of primary battery used shall be included in labels; date change methods shall be described during battery replacement;

d) Ship name and beacon identification data shall be included:

Information provided by EPIRB shall be included in graphic operation instructions of waterproof sign that can be installed on bulkhead. Figure may be used for indicating order of operation mentioned but will not constitute a part of the operation manual;

Training materials: the materials shall involve all configurations, functions, limitation, control equipment, display, alarms and status indications, as well as equipment inspection contents of standard operator.

Maintenance manual: equipment maintenance information shall be included;

Manuals shall include the lists and related explanations of terms, abbreviations, symbols and icons displayed in system or equipment. The user operation interface and various functional menus shall

be described in detail so that the users and surveyors are familiar with the equipment and carry out related operations.

(8) Type test outline and factory test outline

At least, descriptions of the following contents shall be included: sampling for type test, batch grouping of factory test, sampling principles, requirements of testing equipment, test items, test methods, and judging criterion for conformity of test results.

4.2 The scope and detail level of drawings and technical documents submitted shall be adequate to audit and verify the conformity of products with regulations concerned and relevant standards and to carry out inspection and test for appearance, structure and electrical design of products.

4.3 The documents submitted shall be managed and identified in accordance with regulations of manufactory quality management system, and the technical documents shall be such for easy audit with the technical requirements concerned.

5 Technical Requirements of Design

5.1 Electrical safety, adaptability of power supply conditions, environment applicability and electromagnetic compatibility of equipment shall adapt to usage environment of ship and meet test requirements of “portable equipment” or “outdoor equipment” specified in IEC 60945.

5.2 Function and performance requirements

5.2.1 Requirements of equipment performance

- 1) Major structure of equipment, consisting of transmitter, power and antenna installed in the same shell, can be operated by untrained personnel in case of emergency.
- 2) Equipment shell is made from anti-corrosion materials, with color of high visible yellow or orange and possessing the reflective property. The reflecting material shall be at least 25 mm wide and around the beacon part over the waterline. The reflecting material shall meet requirements of Annex 2 in IMO A.658 (16).
- 3) The small floating tether shall be firmly set with the equipment, to tie the equipment to survivor or lifeboat in water. The tether shall be settled properly, preventing it from twining with ship structure under the float-free condition. In addition, the tether shall not hinder EPIRB floating away from ship. The tether is 5 m~8 m long and its breaking strength shall be at least 25 kg.
- 4) 0.75 cd low load end-around lights, activated in dark, shall be set for the equipment, its flash rate is 20-30 times per minutes and duration time of each flash is from 1 μ s to 0.1 s, so as to indicate the position for surrounding survivors and rescue units. Small light shall be installed on the top, ensuring the visible radiation range greater than the hemisphere area; small light, under any lighting condition, shall start to flash within 2s if EPIRB is activated manually. Distress signal shall not be transmitted until EPIRB is activated manually after 47 s but not later than 5 min.
- 5) For equipment requiring external power or data link, any connector shall be anti-corrosive and capable of preventing unexpected disconnection. Connection device shall not hinder the release of EPIRB.
- 6) The equipment shall at least maintain water tightness for 5 min in 10 m deep water.
- 7) Considering 45 °C temperature difference between installation position and equipment immersing in water, EPIRB performance shall be free from adverse marine environment, condensation and water leakage.
- 8) The equipment shall vertically float in still water and shall be of positive stability and sufficient buoyancy force under marine conditions.
- 9) The equipment shall not be damaged but float positively in water when falling from the place with height of 20 m to water.

- 10) EPIRB, including its labels, shall be free from excessive damage due to seawater or oil or oil-water, and shall be strongly resistant to deterioration effect when exposing to sunlight for a long time.
- 11) The storage temperature of equipment is $-30^{\circ}\text{C} \sim +70^{\circ}\text{C}$.
- 12) The equipment shall be free from effect under the wind speed reaching 100 kn (52m/s).
- 13) EPIRB shall be of controllable and adequate size, ensuring simple and satisfactory operation. In addition, EPIRB can be operated by person in life jacket. The equipment shall enable manual start-up and manual shutdown, for which measures preventing malfunction shall be taken. Manually-activated distress alarm shall at least include 2 independent actions and each of them will not activate the position-indicating beacon. EPIRB, under drying conditions, will be transferred from the release unit, enabling no automatic activation.
- 14) The equipment shall be configured with indicating devices indicating signals being transmitted, and its battery shall be sufficient to ensure the position-indicating beacon continuously operating for 48 h at least.

5.2.2 Performance requirements for float-free release unit

- 1) The EPIRB shall be the float-free type, allowing reliable operation even under the extreme sea conditions. The equipment shall be automatically activated after free floating.
- 2) The equipment shall be automatically released and floated before reaching 4 m in water in any heel angle and trim angle.
- 3) The equipment shall be made of anticorrosive plastics, preventing failure. Electroplating or metal plating treatment in other forms shall not be carried out for the components.
- 4) Operating instructions about manual release shall be labeled. EPIRB shall be manually released from the float-free release unit without activation of transmitter.

5.2.3 Composition

EPIRB mainly consists of digital message generator, modulator, 406 MHz transmitter, battery, antenna and shell.

5.2.4 Functions of digital message generator

The digital message generator is used for controlling modulator and transmitter through the key modulation mode and for sending information defined in Section 0 “Digital Message”.

5.2.5 Repetition period

A random number generated within $47.5\text{ s} \sim 52.5\text{ s}$ is featured with an average interval of 50s.

5.2.6 Total transmission time

Total transmission time (measured at the 90% power point):

— Elapsed time of short message: $440 \times (1 \pm 1\%)$ ms;

— Elapsed time of long message: $520 \times (1 \pm 1\%)$ ms;

5.2.7 Digital message

5.2.7.1 Short message

Transmit signal with elapsed time of $280 \times (1 \pm 1\%)$ ms contains 112-bit message and its bit rate is $400 \times (1 \pm 1\%)$ bps.

5.2.7.2 Long message

Transmit signal with elapsed time of $360 \times (1 \pm 1\%)$ ms contains 144-bit message and its bit rate is $400 \times (1 \pm 1\%)$ bps.

5.2.7.3 Bit synchronization

Bit synchronization consists of a series of “1”, occupying the first 15 bits.

5.2.7.4 Frame synchronization

Frame synchronization consists of 9 bits, occupying bits from B16 to B24. The frame synchronization code, under normal operation, is “000101111”.

5.2.7.5 Format flag

B25, the format flag, indicates the length of message.

5.2.7.6 Message content

It refers to data contents of the rest 87 bits (short message) or 119 bits (long message).

5.2.8 Transmitting frequency

The carrier frequency of EPIRB shall be $f \pm 1$ kHz. In addition, the carrier frequency shall be free of variation exceeding +2 kHz or -5 kHz within 5 years. f (frequency) shall be consistent with that defined in C/S T.012.

5.2.9 Stability of transmitting frequency

5.2.9.1 Short-term stability of transmitting frequency

Short-term deviation in transmitting frequency shall not be greater than $2 \times 10^{-9}/100$ ms.

5.2.9.2 Mid-term stability of transmitting frequency

Mid-term stability of transmitting frequency shall be defined through the following two factors:

- a) Average slope: the average slope based on the 15 -min period shall not be greater than 1×10^{-9} /mins;
- b) Residual frequency variation: it refers to that the variation based on the average slope shall not be greater than 3×10^{-9} /mins.

5.2.10 Output power of transmitter

The transmitter continuously runs for 24h per day and its output power measured under 50Ω load shall be $5 \text{ W} \pm 2 \text{ dB}$ (i.e., $35 \text{ dBm} \sim 39 \text{ dBm}$) under any air temperature. Rise time of output power measured at 10% \sim 90% power points shall be lower than 5 ms.

5.2.11 Antenna property

Antenna property is defined according to the position angle and the elevation angle between $5^\circ \sim 60^\circ$, and its measurement shall consider the actual operation situation as possible.

- a) Beam pattern: hemisphere;
- b) Polarization mode: RHCP or linear polarization;
- c) Gain: $-3 \text{ dBi} \sim 4 \text{ dBi}$;
- d) Antenna VSWR: no greater than 1.5:1.

5.2.12 Spurious emission

Spurious emission within the wave band shall not exceed signal distribution in Figure 1 if it is measured at the resolution bandwidth of 100 Hz.

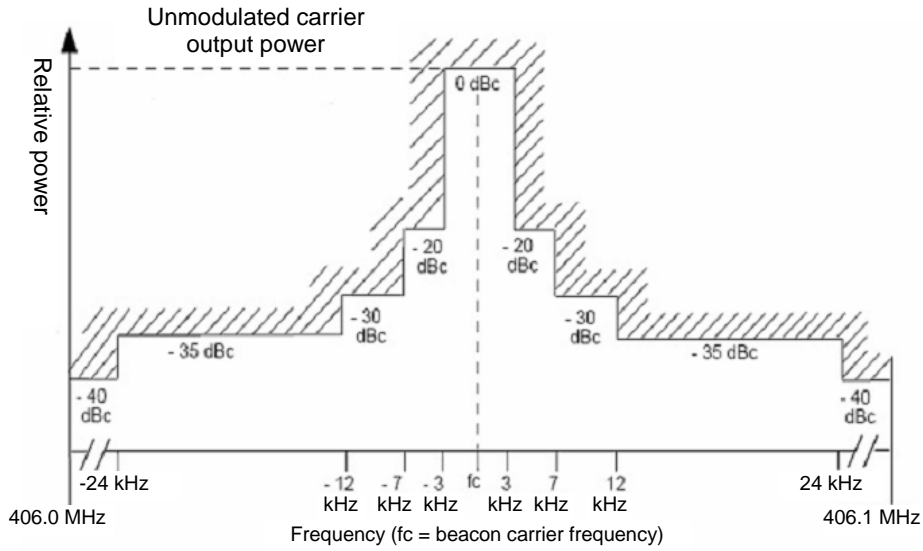

Figure 1 Diagram of Spurious Emission Distribution within Frequency Band from 460.0 MHz to 406.1 MHz

5.2.13 Data coding

Data is coded through biphas L, as shown in Figure 2.

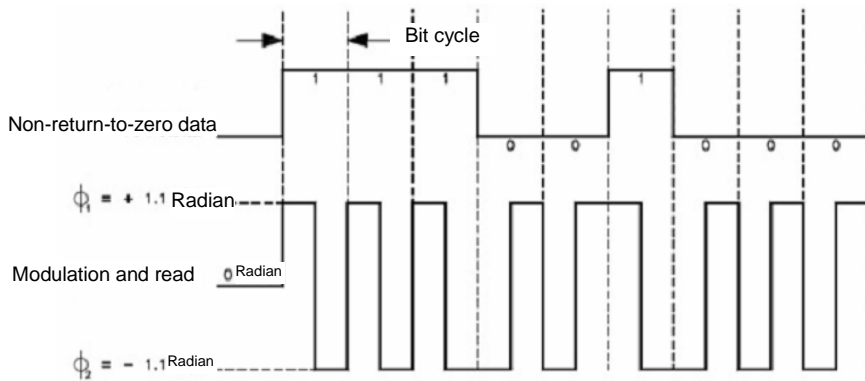

Figure 2 Schematic Diagram of Data Encoding and Modulation

5.2.14 Modulation

Phase modulation

The carrier shall be converted to 1.1 rad \pm 0.1 rad through phase modulation and the schematic diagram of modulation is as shown in Figure 2.

Modulated rise and fall time of waveform

Rise (τ_R) and fall (τ_F) time of modulated waveform shall be $150 \mu\text{s} \pm 100 \mu\text{s}$, as shown in Figure 3.

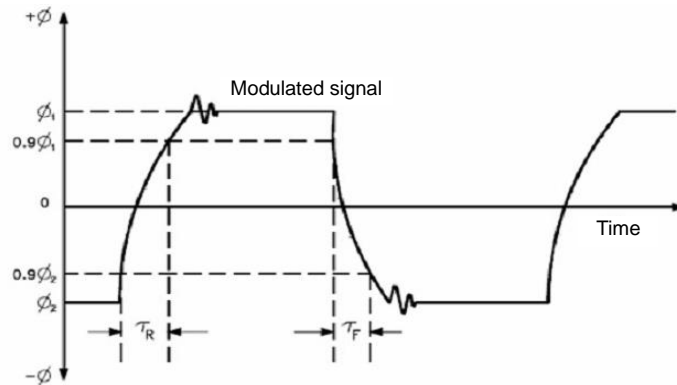

Figure 3 Definition of Modulated Rise and Fall time

Modulation symmetry

Modulation symmetry (as shown in Figure 4) shall be:

$$\frac{|\tau_1 - \tau_2|}{\tau_1 + \tau_2} \leq 0.05$$

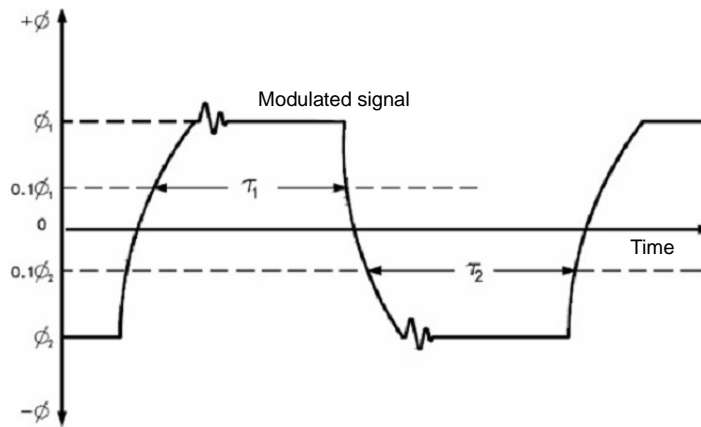

Figure 4 Definition of Modulation Symmetry

5.2.15 Voltage standing wave ratio

Voltage standing wave ratio (VSWR) shall be between 1:1 and 3:1, and EPIRB shall be free from damage caused by load open circuit or short circuit.

5.2.16 Maximum continuous transmitting time

Maximum continuous transmitting time shall not be greater than 45 s.

5.2.17 Operating temperature

Operating temperature range: $-20\text{ }^{\circ}\text{C} \sim 55\text{ }^{\circ}\text{C}$.

Operating temperature range shall be permanently marked on EPIRB.

5.2.18 Temperature gradient

Temperature gradient is as shown in Figure 5.

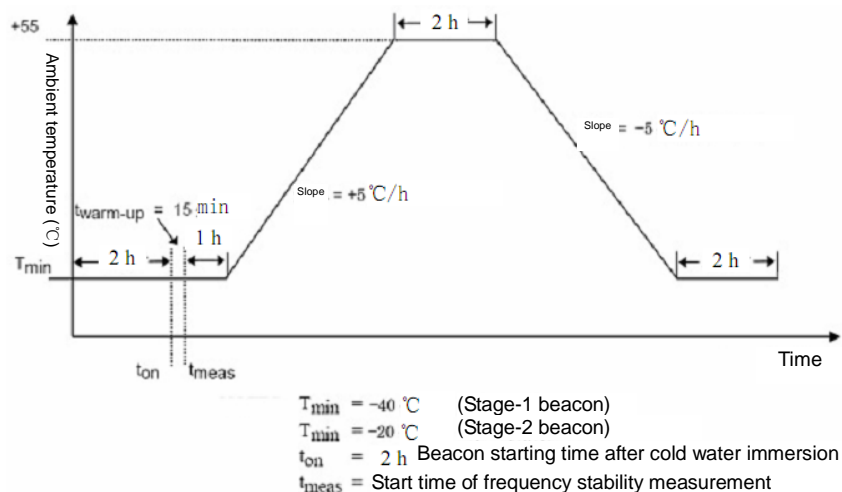

Figure 5 Temperature gradient

5.2.19 Self-testing mode

- 1) EPIRB shall be configured with self-testing mode and contents of self-testing information shall permanently involve flag code of EPIRB;
- 2) The signal, under the self-testing mode, shall contain a frame synchronization string (011010000) and the testing signal will not be received and processed by satellite equipment.
- 3) The self-testing mode shall be activated by separate switches and a specific indicator shall be set, to record status of GNSS self-testing.
- 4) During self-testing, the transmitting time of 121.5 MHz signal shall not exceed the time required by 3 times of audio-frequency sweeping or 1s, and the longer is preferred. (IEC61097-5.3.4)

5.2.20 Activation

The position-indicating beacon allows repetitive manual activation and deactivation and its automatic activation shall not be affected by the process that the beacon is released from the release unit or the beacon is manually activated when floating on water. (IEC61097-5.3.3.2)

5.2.21 Prevention of accidental activation

Check whether effective measures is taken for the position-indicating beacon to prevent accidental activation and whether the beacon in the float-free unit is activated when being washed by water, and ensure that the transmitting time of accidental activation at 406 MHz will not exceed 45 s.

EPIRB, after activation, shall not transmit the distress message within one repetition period at least. (IEC61097-5.3.1)

5.2.22 Washing prevention for float-free unit

Install the position-indicating beacon and the release unit installed on bracket on a test fixture, and wash the equipment with water flow from hose for 5 min. Hose nozzle shall be in nominal diameter of 63.5 mm and its water supply rate shall be 2300 L per minutes. End face of the nozzle is 3.5 m away from the position-indicating beacon and is 1.5 m away from the upper part of antenna base. During test, the nozzle or equipment shall be moved, ensuring that the water flow washes the area within 180 ° of the position-indicating beacon at least and is perpendicular to equipment in the standard installation place. The position-indicating beacon shall not be released and activated when the float-free unit is washed. (IEC60945-8.8)

5.2.23 Buoyancy test

Spread the antenna and immerse the equipment into fresh water (standard domestic tap water) at any angle; make the equipment pass through the vertical position within 2s when the equipment is just under the water.

The equipment will vertically float on the still fresh water and the antenna base is at least 40 mm away from the water surface.

When one of following measurement methods is adopted, the reserve buoyancy of equipment shall be 5% at least.

Measure the buoyancy with scale plate after completely immersing the equipment in water. The proportion of buoyancy to equipment weight shall not be lower than 1.05;

The water line depends on the equipment floating in water. The proportion of the total volume to that under the water line shall not be lower than 1.05; (IEC61097-5.3.2.2)

5.2.24 Flash test

Flashlight shall be started within 2s after manual activation of the position-indicating beacon under any light condition. Distress signal shall not be transmitted until EPIRB is activated manually after 47 s but not later than 5 min.

Respectively check effective light intensity, flash duration and flash rate under normal temperature and extreme temperature. The effective light intensity is defined through the following formula (referring to 10.4.2 in IMO Resolution MSC.81(70)):

$$\frac{\int_{t_1}^{t_2} i \cdot dt}{0,2 + (t_2 - t_1)}$$

where, i refers to instantaneous brightness; 0.2 is the Blondel-Rey constant; $t_2 - t_1$ refers to integral limit of time within a very short time (unit: seconds).

Under the lower part covered by the entire episphere, the arithmetic mean value of effective light intensity shall not be lower than 0.5 cd. The flash duration shall be between 0.001 ms~100 ms. The flash rate is 20-30 times per minutes. If the extreme temperature test is unfeasible in the environmental chamber, methods approximately meeting required conditions can be adopted. (IEC61097-5.3.3.4)

5.2.25 Color and reflecting material

Check whether color of the position-indicating beacon is bright yellow/orange, whether the part over water line is applied with reflecting materials; the area of reflecting materials shall not be less than 25 cm², and the width shall not be lower than 25 mm and the area observed from any angle in the horizontal direction shall not be lower than 5 cm². (IEC61097-5.3.5)

5.2.26 Tether

Check whether the floating tether is firmly fastened on the position-indicating beacon for application of survivor in water or life float. Reasonable design shall be adopted for tether, preventing it from being trapped on ship structure during free floating. The tether shall be 5-8 m long and its breaking strength shall not be lower than 25 kg. (IEC61097-5.3.6)

5.2.27 Marine environmental impact

Check whether beacon materials and its surface materials specified in manufacturer's information are susceptible to long-term impact of seawater, oil and sunlight. (IEC61097-5.3.7)

5.2.28 Human engineering

Check whether the design of beacon dimension and outline structure allow person in survival suit to operate the equipment easily, including taking it out from shell, manual activation and deactivation and loosening tether. (IEC61097-5.3.8)

5.2.29 Activated indication function

Before activation of position-indicating beacon, user shall be notified that the battery level may decrease. In addition, no restoration function will be set for user. For example, a strip seal is required to be opened before manual activation but cannot be restored by user, and the instruction shall not be activated during self-testing. (IEC61097-5.3.9)

5.2.30 Strong wind

It is judged according to information provided by manufacturer.

5.2.31 Freezing

It is judged according to information provided by manufacturer.

5.2.32 Float-free unit

Material of float-free unit

Material of float-free unit and its label shall be resistant to corrosion and free from influence of sea water, oil and sunlight. The release unit of float-free unit shall not contain components with metal exposed outside.

Manual release of float-free unit

Check whether the position-indicating beacon can be manually released from the float-free unit without any tool.

Automatic release of float-free unit

Immerse the position-indicating beacon installed on automatic release unit into water and complete all tests at the standard temperature. Record the water temperature. And then perform the following tests in any order. Successively perform six tests for equipment at the standard temperature:

- 1) In normal assembly position (defined in equipment manual);
- 2) Starboard rotating 90 °;
- 3) Port rotating 90 °;
- 4) Head over heels for 90 °;
- 5) Tail over heels for 90 °;
- 6) Inverting the position.

The equipment shall be automatically released and floated before reaching 4 m in water in any heel angle and trim angle. Pressure (about 40) equivalent to that from the water depth can be also adopted.

The extreme temperature test shall be carried out for the normal assembly position defined in equipment manual. If the extreme temperature test is unfeasible in the environmental chamber, methods approximately meeting required conditions can be adopted.

Air temperature control apparatus for the equipment can be connected before and after test.

Test and inspection described in environment test, after each release from float-free unit, shall be carried out.

After each release, performance test shall be completed at every specific temperature.

Excepting the one-time hydrostatic releaser, the simplest method shall be adopted without activation of position-indicating beacon, to evaluate normal operation of automatic release mechanism.

5.2.33 Label of position-indicating beacon

Check whether the beacon label meets the following requirements:

- a) Describe operations of manual activation, deactivation and self-testing in English at least.
- b) Warn that the position-indicating beacon can only be used in case of emergency;
- c) Beacon type and level, battery type and warranty period shall be marked. The date can be changed after battery replacement;
- d) Ship number, beacon ID, call sign, MMSI and nationality shall be included.

5.2.34 Label of float-free unit

Label of float-free unit shall be marked in English, at least including the following contents:

- a) Manual release instructions;
- b) Type of position-indicating beacon;
- c) Level of position-indicating beacon;
- d) Maintenance and replacement date.

5.2.35 Control function of position-indicating beacon

Control function and status of position-indicating beacon shall meet requirements specified in the following table1:

Table 1 Control Function and Status of Position-indicating Beacon

Switch position		Beacon status		Status of release unit		Transmitting status	
Open	Automatic	Soaking*	Drying	Popping	Not popping	Open	Close
×		×		×		×	
×		×			×	×	
×			×	×		×	
×			×		×	×	
	×	×		×		×	
	×	×			×		×
	×		×	×			×
	×		×		×		×
*Floating in or immersing in water							

5.2.36 121.5 MHz locating transmitter

For the equipment meeting the requirements of msc.471 (101), the duty cycle of the transmitter has been adjusted. See Annex B of msc.471 (101) for details.

- 1) Technical parameters of locating transmitter
 - a) Carrier frequency: 121.5 MHz \pm 50 ppm
 - b) Peak effective radiation power (PERP): +17 dBm (50mW) \pm 3 dB
 - c) Transmitting duty ratio: 100%
 - d) Modulation duty ratio: 33 % ~ 55 %
- 2) Technical parameter test for locating transmitter

a) Carrier frequency: it can be measured through the frequency meter or spectrometer and shall meet requirements specified in 0 of this Section at the minimum temperature and the maximum temperature.

See D.4.1 in IEC 61097-2:2008 for test methods.

b) Peak effective radiation power: the test can be completed under the normal temperature and the tested beacon shall run for 44 h at least. Ensure that the antenna elevation angle of measuring equipment is $5^{\circ} \sim 20^{\circ}$ (the maximum gain of beacon antenna is preferred) and carry out 12 times of measurement per $30^{\circ} \pm 3^{\circ}$ of $0^{\circ} \sim 360^{\circ}$ in the horizontal plane; the mid-value of PERP shall be from 25 mW \sim 100 mW and the proportion of the maximum to the minimum in 11 test results shall not exceed 4:1.

See D.4.2 in IEC 61097-2:2008 for test methods.

c) Transmitting duty ratio: monitor 121.5 MHz transmitting signal with proper test instrument and confirm that its transmission will not be interrupted unless the 406 MHz signal is being transmitted (no greater than 2 s).

See D.4.4 in IEC 61097-2:2008 for test methods.

d) Modulation duty ratio: it refers to the ratio of positive modulation period A to instantaneous baseband audio period B. Refer to Figure 6.

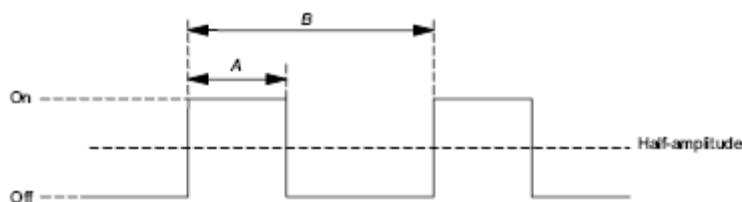

Figure 6 Typical modulation waveform

The modulation duty ratio at the half-amplitude point of modulation envelope can be calculated through the following formula:

$$\text{Modulation duty ratio: } (A/B) \cdot 100\%$$

The modulation duty ratio shall be measured at the starting point, the intermediate point and the end of modulation signal. The modulation duty ratio shall be between 33 % \sim 55 %.

See D.3.d) in IEC 61097-2:2008 for test methods.

5.2.37 Navigation system

In addition to location data encoding test, it is ensured that the 406 MHz signal will not be affected during all tests of navigation system and position-indicating beacon runs normally throughout the entire operating life. The following tests are completed at the normal environment temperature,

and effectiveness of all BCH codes will be checked during the tests. Any defective BCH code shall be specified in the testing report.

If COSPAS-SARSAT testing reports indicate that the test item has been approved, the test will not be required.

1) Default position data

If no effective positional information in the beacon memorizer is provided to the 406 MHz transmitter, default values shall be transmitted, as shown below:

- a) All bits with units of “degree” shall be “1” and north-south and east-west mark bits shall be “0”;
- b) All bits with units of “minute” shall be “0” and the Symbol Δ shall be “1”;
- c) All bits with units of “second” shall be “1”.

2) Position acquisition time and accuracy

- a) Input proper navigation signals or navigation data into the position-indicating beacon in the known place. Activate the position-indicating beacon and ensure that positional information has been inputted into data information within the prescribed time (1 min for the external navigation system; 10 min for the internal navigation system). For the standard or domestic positioning protocol, the data deviation of code shall not be greater than 500 m; for the user positioning protocol, the deviation shall not be greater than 5.25 km. Shut down the position-indicating beacon after test.
- b) Change navigation data input or navigation position information (above 5 km), activate the position-indicating beacon and confirm that information coding is completed by the beacon within the prescribed time. For the standard or domestic positioning protocol, the data deviation of code shall not be greater than 500m; for the user positioning protocol, the deviation shall not be greater than 5.25 km. Shut down the position-indicating beacon after test.

The above results shall be recorded in tables and the unsatisfactory initial test with its causes shall be also recorded. For the subsequent items, the test shall be performed for 5 times at least under the same settings.

The position-indicating beacon set with the internal navigation system shall be placed in the open ground, ensuring that clear signals can be received by the satellite, and settings of the beacon shall be in compliance with manufacturer’s instructions.

3) Update interval of position code data

If the position-indicating beacon enables updating position code data, reasonable navigation signals or navigation data shall be inputted into the beacon, to ensure that digital signals will not be updated within 5 minutes after the last update. During the test, beacon position or signals

transmitted by navigation satellite simulator can be changed. Ensure that digital information changed by the position-indicating beacon is consistent with design of manufacturer. If the beacon fails to update code information, it will be ensured that code information will not be changed when navigation information or navigation data is inputted into the beacon. Time interval of the first update data shall be recorded in the tables. Test configurations can be determined by manufacturer and test organization through negotiation and testing each configuration is unnecessary.

4) Clearing of positional information after deactivation

After the above tests, deactivate and reactivate the position-indicating beacon. Do not input navigation signals or navigation data during beacon reactivation, and confirm that the last positional information has been cleared and correct default values have been encoded; Record results in the tables.

5) Time interval of external position data input and update

If position information is inputted by the position-indicating beacon before the beacon is activated by the external navigation system, the input interval of navigation information shall not exceed 20 minutes. The test is as shown below: firstly, activate the beacon and change the initial position data with proper interval. Then, clear the navigation data input and check whether coded data is correct. At last, record interval and test result in the tables.

6) Final effective position

Clear navigation signal or navigation data input and check whether the final effective navigation information can be maintained by the position-indicating beacon for 4 h (error: 5 minutes) after information loss. Check whether positional information is cleared after 4 h (error: 5 minutes) and input correct default values. Record transmitting duration of final effective navigation information in the tables and confirm the default values determining that the information can be correctly transmitted by the beacon.

5.2.38 AIS function

This is a new requirement of msc.471 (101). See msc.471 (101) general and RF signal requirements for details. The technical characteristics and message format of EPIRB transmission signal refer to the latest cospas SARSAT system document C / s t.001 or C / s t.018.

5.2.39 Environmental adaptation test

Environmental adaptation test shall be carried out in accordance with relevant regulations in IEC 61097-2:2008. If COSPAS-SARSAT testing reports indicate that the test item has been approved, the test will not be required.

e) Dry heat storage test.

f) Dry heat function test.

- g) Damp heat function test.
- h) Vibration test.
- i) Impact test.
- j) Hard surface drop test.
- k) Drop test.
- l) Heat shock test.
- m) Water immersion test.
- n) Spurious emission test.
- o) Low temperature and battery capacity test.
- p) Electrostatic discharge immunity test.
- q) Radio frequency interference immunity test.
- r) Corrosion resistance test.
- s) Safe distance test for magnetic compass.

6 Raw Material and Parts

Raw material and parts of products shall be controlled in compliance with existing specifications of CCS.

7 Type Approval and Unit/Batch Test

7.1 Principle

The equipment shall pass type approval of CCS. Issuing, maintaining, modification, renewal and withdrawal of the type approval certificate shall be completed as per relevant requirements of Chapter 3 in Title 1 of *Rules and Regulations for Classification of Sea-going Steel Ships*.

The equipment shall pass the COSPAS-SARSAT type approval test and hold the test report and the type approval certificate.

7.2 Selection of typical samples and test planning

Model and specification of test sample shall be technically representative and cover scopes of products applied and submitted for type approval. Test samples shall be randomly selected by CCS surveyor in the product manufactory.

7.3 Test agencies

An authoritative and impartial test agency, responsible for the type approval test, shall be approved by CCS, and shall have been certificated by international/domestic laboratory concerned. Considering some test items (excluding BeiDou performance test), they can be completed in the manufactory with approval and consent of CCS surveyor and under field supervision if relevant test conditions are fulfilled.

During determination of test agencies, test conditions specified in IEC 61097-2 shall be fully considered and written documents shall be submitted to CCS surveyor for approval.

7.4 Type approval test items and requirements

See the attached table for type approval test items.

Table 2 Equipment Functions, Performance Test Methods and Required Test Results

S/N	Test items	Test methods	Remarks
1	Digital message generator	C/S T.007 A.3.1	Refer to COSPAS-SARSAT reports
2	406 MHz transmitter modulation	C/S T.007 A.3.2.3	Refer to COSPAS-SARSAT reports
3	Transmitting frequency of 406 MHz transmitter	C/S T.007 A.3.2.1	Refer to COSPAS-SARSAT reports
4	Output power of 406 MHz transmitter	C/S T.007 A.3.2.2	Refer to COSPAS-SARSAT reports
5	Self-testing mode	IEC 61097-2, 3.3.4	
6	Activation	IEC 61097-2, 5.3.3	
7	Prevention of accidental activation	IEC 61097-2, 5.3.1	
8	Buoyancy test	IEC 61097-2, 5.3.2	
9	Flash test	IEC 61097-2, 5.3.3.3	
10	Color and reflecting material	IEC 61097-2, 5.3.5	
11	Tether	IEC 61097-2, 5.3.6	
12	Marine environmental impact	IEC 61097-2, 5.3.7	It is judged according to the information provided by manufacturer.
13	Human engineering	IEC 61097-2, 5.3.8	
14	Activated indication	IEC 61097-2, 5.3.9	
15	Strong wind	IEC 61097-2, 5.6.3	It is judged according to the information provided by manufacturer.
16	Freezing	IEC 61097-2, 5.6.2	It is judged according to the information provided by manufacturer.
17	Float-free unit	IEC 61097-2, 5.7	
18	Label of position-indicating beacon	IEC 61097-2, 5.12.1	
19	Label of float-free unit	IEC 61097-2, 5.12.2	
20	Control function of position-indicating beacon	IEC 61097-2, 3.2.e)	
21	121.5 MHz locating transmitter	IEC 61097-2, D.4	
22	Navigation system	C/S T.007 A.3.8	

Table 3 Environmental Condition Test Methods Specified by IEC 61097-2 and Required Test Results

S/N	Test items	Test methods	Remarks
1	Dry heat storage test	IEC 61097-2, 5.17.1 and IEC 60945, 8.2	

I-04 (202111) SATELLITE EMERGENCY POSITION-INDICATING RADIO BEACON

2	Dry heat function test	IEC 61097-2, 5.17.1 and IEC 60945, 8.2	
3	Damp heat function test	IEC 61097-2, 5.17.2 and IEC 60945, 8.3	
4	Vibration test	IEC 61097-2, 5.17.6 and IEC 60945, 8.7	
5	Impact test	IEC 61097-2, 5.17.7	
6	Hard surface drop test	IEC 61097-2, 5.17.5.1 and IEC 60945, 8.6	
7	Drop test	IEC 61097-2, 5.17.5.2 and IEC 60945, 8.6	
8	Heat shock test	IEC 61097-2, 5.17.4 and IEC 60945, 8.5	
9	Water immersion test	IEC 61097-2, 5.17.8 and IEC 60945, 8.9	
10	Spurious emission test	IEC 61097-2, 5.19	
11	Low temperature and battery capacity test	IEC 61097-2, 5.15.1	
12	Electrostatic discharge immunity test	IEC 61097-2, 5.18 and IEC 60945, 10.9	
13	Radio frequency radiation interference immunity test	IEC 61097-2, 5.18 and IEC 60945, 10.4	
14	Corrosion resistance test	IEC 60945, 8.12	
15	Safe distance of magnetic compass	IEC 60945, 11.2	

Table 4 COSPAS-SARSAT Type Approval Test Methods and Required Test Results

S/N	Test items	Referenced clauses	Remarks
1	Measurement of normal temperature indicator	C/S T.007 A.2.1	
2	Measurement of high temperature indicator	C/S T.007 A.2.1	
3	Measurement of low temperature indicator	C/S T.007 A.2.1	
4	Inspection under self-testing mode	C/S T.007 A.3.6	
5	Temperature shock test	C/S T.007 A.2.2	
6	Temperature gradient test	C/S T.007 A.2.4	
7	Operating time test under the minimum temperature	C/S T.007 A.2.3	
8	Beacon antenna test	C/S T.007 A.2.6	
9	Beacon coding software test	C/S T.007 A.2.8	
10	Navigation system test	C/S T.007 A.3.8	
11	Satellite quality test	C/S T.007 A.2.7	
12	Frequency stability test	C/S T.007 A.3.2.1	

Table 5 Criterion for electromagnetic environment test

Criterion A	The tested equipment, continuously running to end of test, shall be free of function failure and performance degradation during the test and its indicators shall meet relevant standards.
Criterion B	During the test, temporary function failure or performance degradation is allowable but status and stored data shall not be changed. After the test, function failure and performance degradation are unacceptable.
Criterion C	During the test, temporary function failure and performance degradation are allowable and they can be automatically or manually restored in accordance with standards concerned and operating instructions of manufacturer.

Table 6 Performance Inspection List

Inspection items	Technical requirements
Frequency error at 406MHz	± 1 kHz
Information coding (15 Hex ID)	Correct
Information coding (112 or 144 Hex)	Correct
121.5 MHz Locating signal frequency	Correct

Table 7 Performance Test

Measurement parameters	Technical requirements	Unit	Remarks
1. Output power - Power output of transmitter - Rise time of power output - The first 1 ms power of output pulse	35~39 <5 <-10 dBm	dBm ms √	
2. Digital message	Decoded correctly	√	Beacon detector
3. Digital message generator - Repeat rate TR: Average TR Minimum TR Maximum TR Standard deviation - Bit rate: Minimum fb Maximum fb - Primary pulse delay	48.5~51.5 47.5~48.0 52.0~52.5 0.5~2.0 ≥ 396 ≤ 404 ≥ 47.5	sec sec sec sec bit/sec bit/sec sec	
4. Modulation - Biphase L - Rise time - Fall time - Phase deviation: Positive polarity - Phase deviation: Negative polarity	50~250 50~250 +(1.0~1.2) -(1.0~1.2)	√ us us rad rad	
5. 406 MHz Transmitting frequency - Rated value - Stability of short-term frequency - Stability of mid-term frequency (slope) - Stability of mid-term frequency Residual frequency variation	C/S T.001 ≤2*10 ⁻⁹ (-1~1)*10 ⁻⁹ ≤3*10 ⁻⁹	MHz /100ms /min	
6. Spurious emission (loaded with 50 Ω) (406.0 – 406.1MHz)	C/S T.001 mask	√	

7.5 Unit/batch inspection

As required by CCS, unit/batch inspection shall be carried out for products before leaving factory, and certificates of marine products shall be issued.

After type approval, manufactory shall control product production and test process in accordance with quality control documents submitted during approval, and shall complete required factory tests for each marine product and provide factory test reports. Based on review for factory test reports, CCS surveyor will inspect products at the rate of 5% through random check (no less than 2 sets). Unit/batch inspection shall at least include the following tests:

- Review for main element (part) data;
- Confirmation of software version;
- Appearance inspection;
- Functional confirmation test:
- Performance test: positioning accuracy

Test items and sampling amount may be added if the surveyor considers it necessary.