



Guideline No.: W-10(202012)

# **W-10**

# **COPPER ALLOY PROPELLERS**

Issued date: December 08, 2020

© China Classification Society



**CONTENS**

\_Toc460836196

1 Application.....	4
2 Normative references .....	4
3 Definitions.....	4
4 Plans and documents .....	5
5 Materials and components.....	6
6 Design and technical requirements .....	6
7 Selection of typical samples.....	6
8 Type test .....	6
9 Assessment of welding procedure .....	13
10 Unit/batch inspection .....	17

## **COPPER ALLOY PROPELLERS**

### **1 Application**

1.1 This Chapter applies to the works approval and inspection for cast copper alloy propellers (include copper alloy parts and components such as cast propeller blade, hub and hydraulic oil cylinder of built-up propeller) intended for use in sea-going and inland waterways ships.

### **2 Normative references**

2.1 The basis for approval and inspection of copper alloy propellers are as follows:

- (1) CCS Rules for Materials and Welding
- (2) CCS Rules for Classification of Sea-going Steel Ships;
- (3) CCS Rules for Construction and Classification of Sea-going High Speed Craft;
- (4) CCS Rules for Construction of Sea-going Ships Engaged on Domestic Voyage
- (5) CCS Rules for Construction of Inland Waterways Steel Ships
- (6) CCS Rules for Construction and Classification of Inland Waterways High Speed Craft
- (7) ISO 484/1 Shipbuilding-Ship screw propellers-Manufacturing tolerances-Part 1: Propellers of diameter greater than 2.5 m or ISO 484/2 Shipbuilding-Ship screw propellers-Manufacturing tolerances-Part 2: Propellers of diameter between 0.80 and 2.50 m inclusive or GB 12916 Specification for marine metallic propeller
- (8) ISO 3715 Shipbuilding-Ship screw propellers-List of equivalent terms;
- (9) ISO 1940-1 Mechanical Vibration-Balance Quality Requirements for Rotors in a Constant (Rigid) State.

### **3 Terminology and Definitions**

3.1 For the purpose of this Chapter, the definitions given in CCS Rules for Classification of Sea-going Steel Ships, CCS Rules for Construction and Classification of Sea-going High Speed Craft, CCS Rules for Construction of Sea-going Ships Engaged on Domestic Voyage, CCS Rules for Construction of Inland Waterways Steel Ships , CCS Rules for Construction and Classification of Inland Waterways High Speed Craft , CCS Rules for Materials and Welding and ISO 3715,

GB 12916 Specification for marine metallic propeller apply.

#### **4 Plans and documents**

##### 4.1 Plans and documents submitted for check of products drawings

4.1.1 The plans and calculation documents of propeller should be regarded as a part of ship drawings and submitted to CCS (hereinafter as the Society) for approval along with the latter

4.1.2 In that case the drawing audit department can surely acquire the true and enough particulars about the corresponding ship and main engine, the concerned equipment manufacturer can submit the above mentioned plans and documents on the propeller to the Society for approval.

##### 4.2 Plans and documents submitted for works approval

4.2.1 A manufacturer (including foundry and machining works) intending for propeller works approval should submit the following documents to the Society for approval:

(1) type test program;

(2) welding procedure;

4.2.2 In addition to those in 4.2.1, the following drawings are to be submitted to CCS for information:

(1) particulars of the manufacturer, including the name, address, history, production capacity, technical and inspection personnel, main products, subordinate relationship, trademark, etc.;

(2) details of products for approval, including alloy type, specification (maximum diameter and maximum mass) and delivery condition;

(3) main production equipment and inspection equipment, including the name/purpose, specification and capacity of smelting, casting and heat treatment equipment, equipment for physicochemical examination, non-destructive test, metallographic examination (if applicable) and balancing test;

(4) brief production technology of the products for approval, runner and feeder arrangements, non-destructive testing and repair procedures;

(5) quality management documents and certificate;

- (6) document of entering to the register of enterprise;
- (7) qualification certificates of the personnel engaged in manufacturing and inspection, including at least that for chemical composition analysis, mechanical property test, metallographic examination, non-destructive test, and welding;
- (8) a list of raw materials, including main and auxiliary materials;
- (9) specimen of products quality certificate.

## **5 Materials and components**

Built-up propeller components are to comply with relevant requirements of CCS Rules

## **6 Design and technical requirements**

6.1 The design and technical requirements for propellers are to at least comply with the requirements of CCS Rules for Classification of Sea-going Steel Ships, Rules for Construction and Classification of Sea-going High Speed Craft, CCS Rules for Construction of Sea-going ships engaged on domestic voyage, CCS Rules for Construction of inland waterways ships , CCS Rules for Construction and Classification of inland waterways High Speed Craft , and CCS Rules for Materials and Welding.

## **7 Selection of typical samples**

The selection of typical samples for works approval is based on the following requirements:

- (1) The typical samples are selected according to the types of copper alloy material, in which Cu3 may cover Cu4, and Cu1 and Cu2 may cover each other.
- (2) The diameter of at least one alloy type of propellers is to be more than 90% of the maximum diameter of the products for approval, or the mass more than 80% of the maximum mass of the products declared by the manufacturer.
- (3) Products manufactured by complicated technology are preferably selected.

## **8 Type test**

The type test items and results are to be carried out according to the following requirements. The typical samples are to be cast according to the requirements in 9.1.5, Section 1, Chapter 9, PART ONE of CCS Rules for Materials and Welding.

- (1) Chemical composition analysis: The melting analysis and the chemical composition analysis of product should be carried-out. The chemical composition of product is to comply with the requirements in 9.1.3, Section 1, Chapter 9, PART ONE of CCS Rules for Materials and Welding.
- (2) Metallographic examination: the metallographic examination is applicable to propellers made of Cu1 and Cu2. At least one specimen is to be taken from each heat, and the proportion of  $\alpha$  phase is to be determined as the average value of 5 counts. The test results are to comply with the requirements in 9.1.3, Section 1, Chapter 9, PART ONE of CCS Rules for Materials and Welding.
- (3) Mechanical property test: round proportional tensile test specimens with diameter of 14 mm are to be cut from each test sample in accordance with the requirements given in Item 2 of Table 2.2.2.1 in Chapter 2 of PART ONE of CCS Rules for Materials and Welding. The tensile strength, 0.2% proof strength and elongation are to be determined by mechanical property tests. The test results are to comply with the values given in Table 9.1.6.3, Section 1, Chapter 9, PART ONE of CCS Rules for Materials and Welding.
- (4) Visual, dimensional and geometrical tolerances examination: the external quality is to comply with the requirements given in CCS Rules for Materials and Welding. The dimension, dimensional and geometrical tolerances and surface roughness are to be in accordance with the drawings approved by CCS. Where it is not specified, the requirements given in ISO 484 Shipbuilding-Ship screw propellers-Manufacturing Tolerances or GB 12916 Specification for marine metallic propeller apply.
- (5) Non-destructive test: each propeller and its components are to be subject to NDT according to ISO3452-1:2013 or the standard approved by CCS in accordance with the relevant requirements in Section 4, Chapter 8 of PART THREE of CCS Rules for Materials and Welding. All propeller castings are to be subject to dye penetration inspections in accordance with three zones A, B, and C. The inspections of Zone A are generally to be carried out in the presence of the Surveyor. Inspections of Zones B and C are to be performed by the manufacturer and a test report is to be submitted to the Surveyor for confirmation, or may be witnessed by the Surveyor as he requires. The NDT results are to comply with the requirements given in Section 4, Chapter 8 of PART THREE of CCS Rules for Materials and Welding.
- (6) Static balancing: static balancing test is to be carried out on all propellers.
  - ① When the propeller subjected to static balancing test is set upright on horizontal type

static balancing equipment , indifferent equilibrium test is to be carried out first, then followed by weighing test. The frictional moment of the core shaft of static balancing equipment is not to exceed:

$$M = \frac{G}{2} R$$

where:  $G$  - calculated weight suspending;

$R$  - radius of propeller.

The calculated weight suspending is to be in accordance with the drawings approved by CCS. Where it is not specified, the following value is to be taken (whichever is lesser):

$$G = C \frac{m}{Rn^2}$$

$$G=Km$$

where:  $G$  - calculated weight suspending, in kg;

$m$  - mass of propeller, in kg;

$R$  - radius of propeller, in m;

$n$  – rated running speed, in rpm;

$C$  and  $K$ - coefficient

The coefficient  $C$  ,  $K$  is given in the following Table 8(1).

Grade of propeller	Coefficient k value			
	S	1	2	3
$C$	15	25	40	75
$K$	0.0005	0.001	0.001	0.001

Remark:

As the rated running speed of the propeller going up,the calculation outcome according to the above mentioned formulae is to become smaller infinitely,when the calculation outcome as the criterion for weight suspending is difficult to overcome the static friction force, the criterion for weight suspending can be enlarged properly,but should not be greater than 20g.

② When the propeller subjected to static balancing test is placed on upright static balancing

equipment , the unbalance mass measured (the total additional bob-weight which are attached to max. thickness gauge points of one or more blade tips in order to achieve equilibrium) should not greater than the value which equals to 1/2 multiplies the calculation outcome according to the above mentioned formulae ,where  $X_n$  is hub diameter ratio

Where the works is to manufacture only the components (such as blades) of built-up propellers (such as controllable pitch propeller) without fabrication, and the shipbuilder responsible for fabrication has no static balancing conditions, each blade is to be subject to moment balancing test in the works to determine the balancing moment of gravity center of the blade to propeller axis. For controllable pitch propeller with four blades, the balancing moment of each blade to propeller axis is to meet the following formula:

$$\Delta mi = \left| Wi Xi - 1/4 \cdot \sum Wi Xi \right| \leq f W / (2.828 + X_n) \cdot N^2$$

where:  $Wi$  - mass of number  $i$  blade;

$Xi$  - distance between gravity center of number  $i$  blade and propeller axis;

$X_n$  – hub diameter ratio

$N$  – running speed of propeller, in rpm;

$\Delta mi$  is in kg.m.

The coefficient  $f$  is to be taken according to the following Table 8(2):

**Coefficient  $f$  value**

**Table 8(2)**

Grade of propeller	S	1	2	3
$f$	9	12.5	20	37.5

(7) Dynamic balancing: dynamic balancing is generally required for propellers running above 500 rpm, and the permissible unbalanced moments are to comply with the drawings approved by CCS. Where it is not specified, the remaining unbalance mass of propellers are not to exceed the value  $u_{per}$  calculated by the following formula:

$$u_{per} = 30000 G' m / (\pi r n)$$

where:  $u_{per}$  - permissible unbalanced mass, in g;

$G'$  - balance quality, the value takes 6.3 for propellers of Class S;

The value takes 16 for propellers of Class I;

The value takes 25 for propellers of Others Class II;

The value takes 40 for propellers of Others Class III

in mm/s, according to ISO 1940;

$m$  - mass of propeller, in kg;

$r$  - balance radius,  $0.8R$ , in mm;

$n$ - running speed of propeller at rated power of main engine, in rpm.

- (8) Pressure test: the components of built-up propellers with hydraulic fluid cylinders are to be subject to pressure test during products survey. The test pressure is to be in accordance with the drawings approved by CCS. Where it is not specified, 1.5 times the working pressure apply.
- (9) Weighing test: propellers are to be weighed and recorded. The mass tolerance of the first finished product of propeller is generally not to exceed  $\pm 4\%$  of the theoretical mass according to three dimensional model calculation. The mass of the second and the subsequent products are determined according to that of the first finished product of propeller, and the mass difference is generally not to exceed  $\pm 2\%$  of the above mentioned theoretical mass.
- (10) Repairs of defects: the repairs of propellers are to comply with the requirements in Section 4, Chapter 8, PART THREE of CCS Rules for Materials and Welding. Where the propellers have defects in Table 2 subject to weld repair, a detailed welding procedure specification and areas of repairs are to be submitted to CCS for approval, covering the weld preparation, welding procedure, filler metals, preheating, post-heating and inspection. The welding procedure is to be approved by CCS in advance. Detailed requirements are given in Tables 8(3), 8(4) and 8(5).

**Recommended filler metals and heat treatment temperatures**

**Table 8(3)**

<b>Alloy type</b>	<b>Filler metal</b>	<b>Min preheat temp. (°C)</b>	<b>Max. interpass temp. (°C)</b>	<b>Stress relieving temp. (°C)</b>	<b>Hot straightening temp. (°C)</b>
Cu1	Al-bronze <sup>①</sup> Mn-bronze	150	300	350-500	500-800
Cu2	Al-bronze Ni-Mn-bronze	150	300	350-550	500-800
Cu3	Al-bronze Ni-Al-bronze <sup>②</sup> Mn-Al-bronze	100	250	450-500	700-900
Cu4	Mn-Al-bronze	100	300	450-600	700-850

Notes: ① Ni-Al-bronze and Mn-Al-bronze are acceptable.

② Stress relieving not required, if filler metal Ni-Al-bronze is used.

**Weld repair region and area**

**Table 8(4)**

Position of defects	Weld repair	Maximum size of single defect for weld repair S x h (mm <sup>2</sup> x mm)					Total area to be weld repaired	
		D≤1.0m	1.0m< D≤1.5 m	1.5m<D≤2. 5m	2.5m< D≤4.0 m	D>4.0m		
Zone A	Generally not allowed	Repair welding is generally subject to special approval by CCS. In some cases the propeller designer may submit technical documentation to propose a modified zone A based on detailed hydrodynamic load and stress analysis for consideration by the Classification Society. Where such weld repair is applied, after the welding the stress is to be effectively relieved by heat treatment and tested. The condition for special approval is that the area and depth of the single defect beyond the blade thickness of the approved drawing are not to exceed 70% of the maximum size of the single defect permitted in zone B on the pressure face and the total area of defects are not to exceed 3% of the surface area of zone A which is also to be subject to the agreement among relevant parties						
Zone B on the pressure side (B1+B2)	allowed	500x6	1400x7	2500x10	5000x15	7500x15	The total area to be weld repaired for each division on each side is not to exceed 5% of the surface area in the division, but where the total area on one side of a blade doesn't exceed 5% of the area on the side, the total area on zone C on the pressure side or B4 division on suction side and zone C may reach 7%	
Zone B from the root to 0.4R on the suction side (B3 division)		700x8	1500x8	2500x10	5000x15	7500x20		
Zone C and zone B from 0.4R to 0.7R on the suction side (B4 division)		700x8	1500x8	4000x10	7500x15	20000x25		
Inside and outside surface of boss		700x8	1000x8	2000x10	4000x15	10000x25		For inside and outside surface of boss, the total area is not to exceed 5% of the surfaces area. For end faces of boss, the total area is not to exceed 10% of the faces
End faces of boss								

Notes: ① B1 division means the zone B within 0.4R on pressure side, B2 division means the remaining of zone B other than B1 division on pressure side.

② The size of propeller in the table is the net size in the drawings and D is diameter of propeller.

③ The size of defect means the size after the defect is removed.

④ The maximum length of a single defect allowed to be weld repaired is not to exceed two times the square root of the area of a single defect.

**Stress relief treatment time for copper alloy propellers**

**Table 8(5)**

Stress relief temperature (°C)	Cu1 and Cu2		Cu3 and Cu4	
	Hours per 25 mm thickness (h)	Max. recommended total time (h)	Hours per 25 mm thickness (h)	Max. recommended total time (h)
350	5	15	-	-
400	1	5	-	-
450	1/2	2	5	15
500	1/4	1	1	5
550	1/4 <sup>①</sup>	1/2 <sup>①</sup>	1/2 <sup>②</sup>	2 <sup>②</sup>
600	-	-	1/4 <sup>②</sup>	1 <sup>②</sup>

Notes: ① Applicable to Cu2 alloys.

② Applicable to Cu4 alloy only.

③ Unless considered otherwise, the stress relief temperature is between 450°C and 500°C.

④ The heating and cooling is to be carried out slowly under controlled conditions. The heating rate is normally not to exceed 100°C/h, and the cooling rate after any stress relieving heat treatment is not to exceed 50°C/h until the temperature of 200°C is reached.

Where defects exist in typical samples and weld repair is feasible, the weld repair and stress relief heat treatment for specific defects are to be deemed as type test items. Where the welding quality is found unsatisfactory (such as cracks or openings with size over 3 mm) in the test, the test fails. The inspection of weld repair is to be carried out in accordance with 8.4.8, Section 4, Chapter 8, PART THREE of CCS Rules for Materials and Welding.

### 9 Assessment of welding procedure

The welding procedure for copper alloy propeller is to be subject to approval by CCS. The approval is a general approval according to different materials, welding method, welding position, welding grooves, preheating and welding conditions (including stress relief heat treatment). The approval is essential for the propeller manufacturer. The approval is not for specific defects of specific propeller, but for butt weld test specimen to check technical conditions of the manufacturer.

The test specimens for approval are two piece of down-hand and butt-weld specimens of which minimum length is 300mm and minimum width is 150mm and minimum thickness is 30mm, as shown in the following figure9(1):

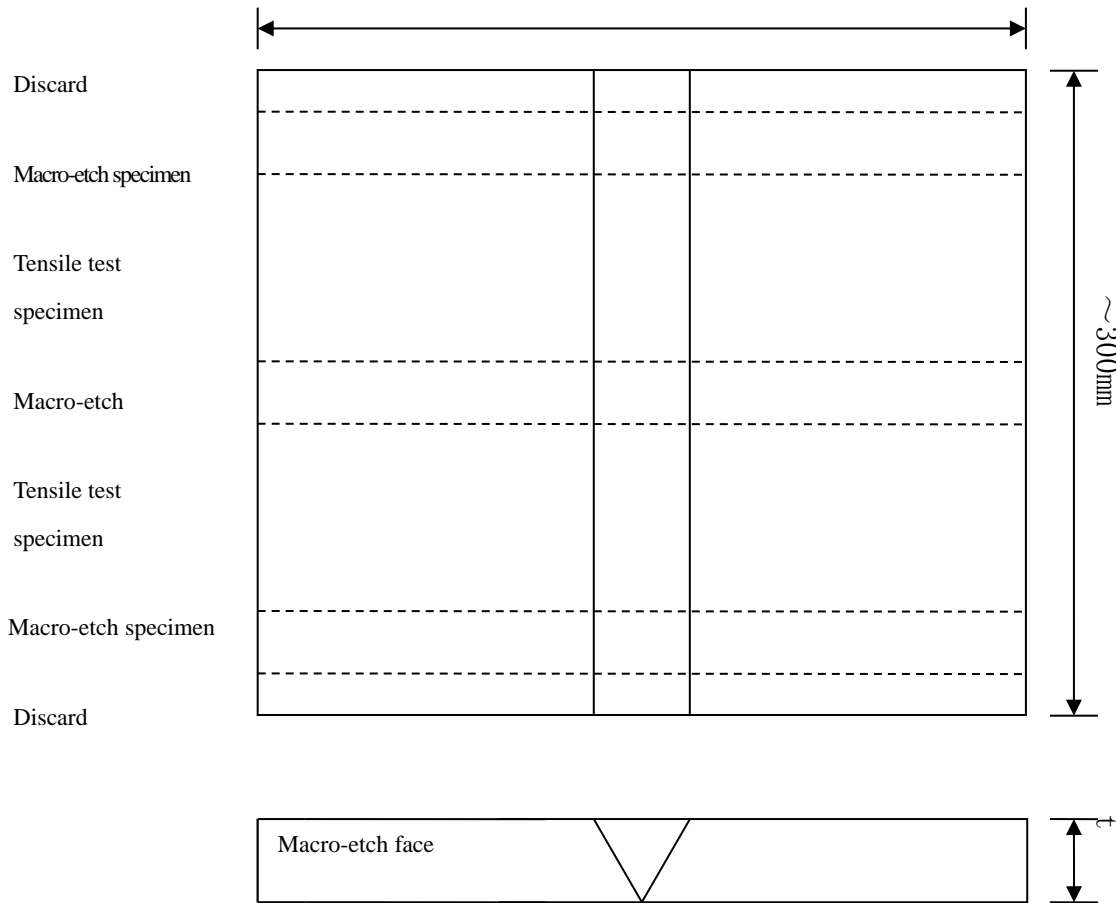

**Figure 9(1) The test specimens for WPS approval**

The preparation of tensile test specimen is as shown in the following figure 9(2).

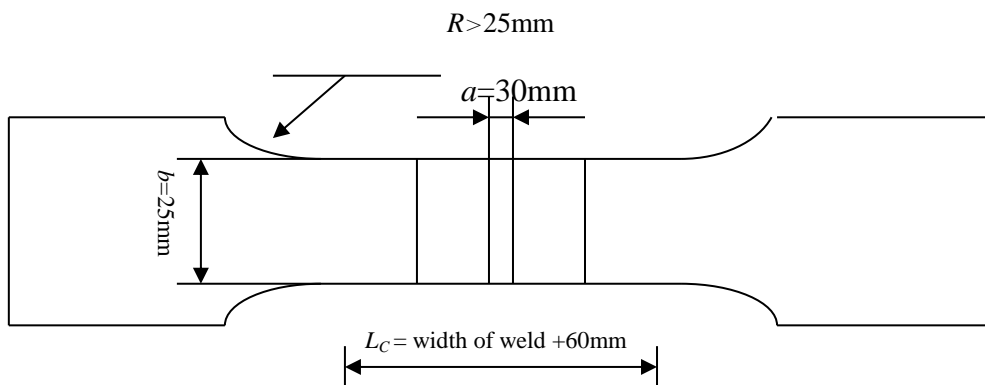

**Figure 9(2) Tensile test specimen**

The tensile strength of two test specimens is to comply with the requirements in the following Table9(1):

**Table 9(1) Tensile strength**

Alloy type	Tensile strength (minimum) N/mm <sup>2</sup>
Cu1	370
Cu2	410
Cu3	500
Cu4	550

Macro-etching: The corrosive liquid for the three macro-etch specimens are to be prepared according to the following proportion:

Ferric trichloride      5 g

Hydrochloric acid      30 ml

Water                      100 ml

The macro-etch specimens are to be free from cracks, lack of fusion or blowholes exceeding 3 mm or slag inclusions.

Non-destructive test: after welding, the welded area is to be subject to dye penetrate and radiographic testing. No cracks or open voids exceeding 3mm are permitted in dye penetrate test. Imperfections detected by liquid penetrant testing are to be assessed in accordance with Section 4, Chapter 8 of PART THREE of CCS Rules for Materials and Welding. Radiographic test is to be carried out referring to the standard on class II of aluminum pressure vessels in JB 4730-2005. This regulation is not to exclude the adoption of subsequent national or industry standards on ultrasonic testing and radiographic testing.

Welding procedure: in the development of welding procedure, Table 8(3) and Table 8(4) may be used as a guidance to select consumables and determine pre-heating temperature, interpass temperature, post-weld heat treatment temperature and time.

Re-testing: Where the result to tensile test of any specimen is unacceptable, duplicate test specimens of the same type are to be prepared from the original welded assembly or from a new assembly welded with the same procedure and using welding consumables from the same batch, and the results of all re-tests are to be satisfactory.

Test record: Welding conditions for test assemblies and test results are to be recorded in welding

procedure qualification record. Forms of welding procedure qualification records can be taken from the Society’s rules or from relevant standards. A statement of the results of assessing each test piece, including repeat tests, is to be made for each welding procedure qualification records. The relevant items listed for the WPS are to be included. The welding procedure qualification record is to be signed by the Surveyor witnessing the test and is to include the Society’s identification.

Range of approval

General: All the conditions of validity stated below are to be met independently of each other. Changes outside of the ranges specified are to require a new welding procedure test. A qualification of a WPS obtained by a manufacturer is valid for welding in workshops or sites under the same technical and quality control of that manufacturer.

Base metal: The range of qualification related to base metal is given in Table 9(2)

**Table 9(2) Range of qualification for base metal**

Copper alloy material grade used for qualification	Range of approval
Cu1	Cu1
Cu2	Cu1; Cu2
Cu3	Cu3
Cu4	Cu4

Thickness: The qualification of a WPS carried out on a weld assembly of thickness t is valid for the thickness range given in Table 9(3)

**Table 9(3) Range of qualification for thickness**

Thickness of the test piece, t (mm)	Range of approval
$30 \leq t$	$\geq 3$ mm

Welding position: Approval for a test made in any position is restricted to that position.

Welding process: The approval is only valid for the welding process used in the welding procedure test. Single run is not qualified by multi-run butt weld test used in this UR.

Filler metal: The approval is only valid for the filler metal used in the welding procedure test.

Heat input: The upper limit of heat input approved is 25% greater than that used in welding the test piece. The lower limit of heat input approved is 25% lower than that used in welding the test piece.

Preheating and interpass temperature: The minimum preheating temperature is not to be less than that used in the qualification test. The maximum interpass temperature is not to be higher than that used in the qualification test.

Post-weld heat treatment: The heat treatment used in the qualification test is to be specified in pWPS. Soaking time may be adjusted as a function of thickness.

### **10 Unit/batch inspection**

10.1 Each propeller and its components are to be subject to test in accordance with CCS Rules. The tests such as chemical composition, metallographic structure(for Cu1 and Cu2), mechanical properties, appearance (including surface roughness), size, dimensional tolerance, NDT, static balancing, dynamic balancing (if applicable), pressure (if applicable) and weighing are to comply with the requirements of CCS Rules and the drawings approved by CCS. When the propeller intend to use in the ship not surveyed by CCS is applied to be surveyed by the Society, strength calculation for the propeller based on the rated power of main engine of the ship and the running speed of the propeller at rated power of main engine(or the rated running speed of main engine and gear box deceleration ratio) should be carried out with satisfaction according to CCS Rules for Classification of Sea-going Steel Ships or CCS Rules for Construction of Inland Waterways Steel Ships by the manufacturer. The strength calculation for the propeller with the drawings of the propeller should be submitted to CCS by the manufacturer.

10.2 size, dimensional tolerance, static balancing, dynamic balancing (if applicable), and pressure (if applicable ) tests and weighing are to be carried out in accordance with 8(4), (6), (7), (8) and (9) of this Chapter.

10.3 The chemical composition analysis report and metallographic structure report should be submitted by the manufacturer to the Surveyor for review. If there is any suspicious, the Society surveyor may check up by sampling.

10.4 The weighing test may be witnessed by the Surveyor as he requires. The mass difference between left-handed propeller and right-handed propeller in the same ship is not to be greater than 2% of the theoretical mass according to three dimensional model calculation. The NDT of zone A of propeller is to be carried-out in the presence of the Surveyor. For NDT of zones B and C, the manufacturer may submit test report to the Surveyor for review.

10.5 The inspect record or report on size and dimensional tolerance and surface roughness should be submitted to the society surveyor for review by the manufacturer. If there is a doubt, the surveyor may spot check these datum.

10.6 Static balancing test of all propeller should be witness by the society surveyor .

10.7 For propellers running above 500 rpm, dynamic balancing test should be carried out in the presence of the surveyor. F

10.8 The items except for those specified above are to be carried out in the presence of the Surveyor. For built-up propellers with hydraulic fluid cylinders, the test pressure of each component is to be 1.5 times the design working pressure in approved drawings and a tightness test is to be carried out after installation onboard ships with 1.25 times the design working pressure.

10.9 After inspection, the manufacturer is to submit quality certificate to the Surveyor for review and as a basis for issue of a certificate of products. The quality certificate is to contain:

- (1) name of the purchaser and order number;
- (2) vessel identification (if known);
- (3) drawing number of propeller;
- (4) diameter, number of blades, pitch, direction of turning;
- (5) heat number, alloy type and chemical composition;
- (6) cast number;
- (7) final mass;
- (8) NDT methods and result;
- (9) proportion of  $\alpha$  phase (only applicable to Cu1 and Cu2);
- (10) results of the mechanical tests
- (11) castings number;

- (12) skew angle for large skew propellers;
- (13) angle of rake;
- (14) static balancing test report;
- (15) dynamic balancing test report (if applicable);
- (16) pressure test report (if applicable);
- (17) measurement report;
- (18) Welding repair record with the photograph(s) of the defect(s) location prior to welding (if no welding operation to all surface of propeller during the whole manufacturing, “No welding” should be remarked in the record).

#### 10.10 Identification and certification

After survey, each propeller and its components are to be marked by the manufacturer with the following items. For solid propeller, the items are to be marked on the turning face near the small end face of boss and between the two blades.

- (1) grade of cast material or corresponding abbreviated designation;
- (2) identification of the manufacturer;
- (3) heat number, casting number or other marking which will enable the full history of the casting to be traced;
- (4) date of final inspection;
- (5) CCS certificate number;
- (6) ice class notation, if applicable;
- (7) skew angle for high skew propellers;
- (8) CCS stamp for accepted castings;
- (9) mass;

- (10) for build-up propellers, in addition to the above items on the surface of the boss, the fillet area of blades are to be marked with serial number of blades and spare blades are to be marked with "BY". Two digits are to be marked on the end face of blade anchor nut and bolt, the first number being that for blade and the second that for nut or bolt.