



# P-03

## AIR PIPE AUTOMATIC CLOSING DEVICES

Issued date: ~~October 20, 2015~~ Jan. 8, 2020

带格式的: 允许文字在单词中间换行

P-03(~~201510202001~~) AIR PIPE AUTOMATIC CLOSING DEVICES

---

Foreword:

CCS Product Inspection and Testing Guideline (hereinafter referred to as this Guideline) contains the technical requirements, inspection and testing criteria related to classification and statutory survey of marine products to be applied for CCS approval/inspection.

This Guideline frees the users to adopt other test methods and requirements which are equivalent to or are stricter than this Guideline.

This Guideline is published and updated by CCS, and is released at <http://www.ccs.org.cn>. Your comments or suggestions are welcomed and may be sent to our email addressed [mp@ccs.org.cn](mailto:mp@ccs.org.cn).

Historical versions and release date: P-03(201510) 2015年10月20日

Main changes and effective date:

According to the revised UR P03 requirements, Discharge/reverse flow test are added to this guideline.

带格式的: 字体: 五号, 非加粗, 字体颜色: 自动设置

CONTENTS

1 Application..... 4

2 Normative references ..... 4

3 Definitions ..... 4

4 Plans and documents ..... 4

5 Materials and components..... 54

6 Design and technical requirements..... 5

7 Type test..... 65

8 Unit/batch inspection ..... 129

1 Application..... 带格式的：默认段落字体，检查拼写和语法

2 Normative references..... 带格式的：默认段落字体，检查拼写和语法

3 Definitions..... 带格式的：默认段落字体，检查拼写和语法

4 Plans and documents..... 带格式的：默认段落字体，检查拼写和语法

5 Materials and components..... 带格式的：默认段落字体，检查拼写和语法

6 Design and technical requirements..... 带格式的：默认段落字体，检查拼写和语法

7 Type test..... 带格式的：默认段落字体，检查拼写和语法

8 Unit/batch inspection..... 带格式的：默认段落字体，检查拼写和语法

## AIR PIPE AUTOMATIC CLOSING DEVICES

### 1 Application

1.1 This Guideline applies to approval and inspection of air pipe automatic closing devices in oil tanks (excluding cargo oil tanks) and water tanks of ships. For other types of air pipe closing devices, reference may be made to in this Chapter.

### 2 Normative references

2.1 CCS Rules for Classification of Sea-Going Steel Ships;

2.2 CCS Rules for Materials and Welding;

2.3 IACS UI LL49 (1980 Rev.1 2008.7), Interpretation to Reg. 20, Annex I of 1966 ICLL Convention. The paragraphs in the above mentioned basis for approval and inspection quoted are part of this Guideline. For quoted documents marked with the date, their subsequent amendments (except corrigenda) or revisions will be inapplicable, hence, it is to meet the requirements of the latest edition of these documents during the product design, manufacture and inspection. However, for those quoted documents without any date marked, the latest edition applies to this Guideline.

### 3 Definitions

The definitions as specified in CCS Rules for Classification of Sea-Going Steel Ships are applicable to this Guideline.

### 4 Plans and documents

4.1 The following plans and documents are to be submitted to CCS for approval:

- (1) Main performance specifications (including type/specification, nominal diameter, lift of floats and purpose);
- (2) General assembly;
- (3) Drawing of main components and parts, such as bodies, floats and guide pillars;
- (4) Calculations of minimum circulation section;
- (5) List of physical and chemical properties of main components and parts;

(6) Type test program.

4.2 The following plans and documents are to be submitted to CCS for information:

- (1) Volume flow-pressure drop characteristic curves, if applicable;
- (2) Main technological documents, such as welding and casting procedures, if applicable;
- (3) Operation instructions for the products.

## **5 Materials and components**

5.1 Materials and components are to comply with relevant requirements of CCS Rules.

5.2 The manufacturer is to control the quality of purchased floats, guide pillars and other main components and parts of air pipe heads.

## **6 Design and technical requirements**

6.1 Technical requirements

6.1.1 The general design requirements are to comply with the requirements as specified in 1.2 of Appendix 4, Chapter 2, PART THREE of CCS Rules for Classification of Sea-Going Steel Ships.

6.1.2 The strength of air pipe closing devices located within the forward 0.25  $L$  on ships of 80 m or over in length, where the height of the exposed deck is less than 0.1  $L$  or 22 m above the summer load waterline, whichever is less, is to be sufficient to withstand the loads as required in 1.7.1.3 and 1.7.1.4, Section 7, Chapter 1, PART TWO of CCS Rules for Classification of Sea-Going Steel Ships.

6.1.3 Air pipe closing devices are to be fitted with flame screens or fly nets made of anticorrosive material in suitable positions. The number of meshes of flame screens is to be not less than 30 for single-layer ones and not less than 20 for two-layer ones (12.7 mm space between two layers); that of fly nets is to be not less than 8.

6.1.4 Closing device of air pipe is to be weathertightly.

6.2 Material requirements

6.2.1 The materials are to comply with the requirements as specified in 1.3, Appendix 4, Chapter 2, PART THREE of CCS Rules for Classification of Sea-Going Steel Ships.

6.2.2 The body material of air pipe closing devices located within the forward 0.25  $L$  on ships of 80 m or over in length, where the height of the exposed deck is less than 0.1  $L$  or 22 m above the summer load waterline, whichever is less, is to be made of ductile metal.

### 6.3 Welding requirements

6.3.1 In the case of main components of welded construction, all welds are to be continuous closed.

## 7 Type test

### 7.1 Selection of typical samples

7.1.1 Air pipe automatic closing devices of each type and size are to be type tested.

7.1.2 If the test of closing devices of air pipes with large diameter is impracticable due to restriction of test equipment, proportionally reduced test samples may be used in flow characteristics test upon approval by CCS.

7.1.3 Where the construction types and specifications of air pipe closing devices are the same and flame screens and fly nets are to be fitted for the purpose of oil tanks and water tanks, the closing devices with large circulation resistance are to be selected for type test.

7.1.4 For the closing device of air pipe with matured or standardized structure, if it is examined that the structure could ensure the weathertightness or other equivalent test is verified the weathertightness of closing device. Manufacturer may be exempted from weathertightness test according to the methods as specified in this Guidelines with the approval by CCS.

7.2 Type test items are to include:

- (1) test of physical and chemical properties of raw materials;
- (2) dimension check;
- (3) performance test;
- (4) flow characteristics test;
- (5) pressure test and immersion/emerging tightness test;
- (6) impact test and compression loading test of non-metallic balls/floats;

(7) impact test of metallic balls/floats;

(8) weathertightness test:-

[\(9\) Discharge/reverse flow test.](#)

7.3 Requirements for type test apparatus/instrumentation

(1) CCS Surveyor is to check the manufacturer’s test laboratory/test bench used as approval test location and confirm compliance with the requirements of 7.3(2), (3) and (4) below. Otherwise, all tests are to be carried out at certification and test organizations recognized by CCS.

(2) Measuring instruments used in the tests are to have valid calibration certificates, and the accuracy of test instruments is not to be lower than that required by Table 7.3.

**Accuracy of Test Instruments**

**Table 7.3**

Measured value	Allowable system error of test instrument (%)
Pressure	±1.0
Flow	±2.5

(3) Water is generally used as test medium. Where air is used in special cases, means are to be available for converting the test graphs into equivalent graphs for water used as test medium to the satisfaction of CCS.

(4) Test apparatus

① The arrangement of test apparatus is shown in figures below:

(a) the typical arrangement of flow characteristics test apparatus is referred to Figure 1;

(b) the typical arrangement of immersion/emerging test apparatus is referred to Figure 2;

(c) the typical arrangement of impact test apparatus is referred to Figure 3;

(d) the typical arrangement of compression loading test apparatus is referred to Figure 4.

② In respect to flow characteristics test apparatus, effective measures are to be taken so that the fluid passing the measuring section will have the following characteristics:

(a) speed distribution with axial symmetry;

(b) isostatic pressure distribution;

(c) whirl due to lack of control.

③ The following basic measures are to ensure the above conditions for flow characteristics test apparatus:

(a) the capacity of test medium is to be sufficient for ensuring static pressure during testing;

(b) straight pipe section is to be used in inlet and outlet circuits of the pump to be tested; and

(c) the length of straight pipe section is to be not less than:

12*D* for inlet pipeline;

4*D* for outlet pipeline;

*D* – outlet diameter of the pump; and

no pressure control valve is to be fitted at the straight pipe section.

(5) Measurement of test parameters is to include:

① flow measurement: the flow measurement is to comply with recognized standards and may be conducted by the turbine flowmeter, tube flowmeter, electromagnetic flowmeter, gravimetric method or volumetric method;

② pressure measurement: the pressure may be measured by the liquid column gauge, or other types of pressure gauges complying with recognized standards;

③ volume measurement: the volume may be measured by the measuring glass.

#### 7.4 Methods and requirements for type test

##### 7.4.1 Test of physical and chemical properties of raw materials

(1) Scope: The body castings produced by the manufacturer are to be subjected to test of physical and chemical properties; if castings are to be purchased, they are to be purchased from such manufacturers approved or accepted by CCS and their furnace samples are to be subjected to

test of physical and chemical properties.

- (2) Sampling: The test samples of castings are to be taken and sealed up on site according to CCS Rules for Materials and Welding.
- (3) The test methods and technical requirements are to be referred to the related chapters in CCS Rules for Materials and Welding.

#### 7.4.2 Dimension check

(1) Scope:

Finished assembly dimensions, wall thicknesses of internal and external chambers of the body, and finished ball/float shapes and wall thicknesses.

(2) Test methods:

- ① Lift measurement of balls/floats – measure by length measuring tool and record the rising height.
- ② Dimensional measurement of air venting passage – measure relative shape dimensions at the nominal diameter of the flange in the body, at the minimum passage in mid-body, at the lift of ball/float and at the outlet (filter screen), and record and calculate the effective circulation area.
- ③ Measurement of wall thickness of the body – measure and record wall thickness at the mid-body and at the flange passage throat.
- ④ Measurement of float dimensions and wall thickness – the measured and recorded diameter and height of floats are to comply with requirements of plans; split the ball/float from the middle and measure the maximum and minimum thickness of float material (steel plate).

(3) Technical requirements:

The tolerance of wall thickness of ball/float is not to exceed  $\pm 10\%$ , and other test results are to comply with plans approved by CCS.

#### 7.4.3 Performance test

(1) Test method:

The air pipe closing device is to be connected to the test apparatus as shown in Figure 1 and subjected to the performance test for withstanding water for 30 min with pressure drop measured at the inlet being not less than 0.05 MPa.

(2) Technical requirement:

After the test, the ball/float, seal receptacle, filter screen of the closing device is free from any damage.

#### 7.4.4 Flow characteristics test

(1) Test method:

Fill the pipe with water, keep the inlet pressure drop of the air pipe closing device within the range of 0 ~ 0.05 MPa and measure evenly 10 times, record the flow, pressure drop data and the pressure drop of the orifice meter, orifice flow constant and Reynolds number.

(2) Technical requirement:

Calculate the local resistance coefficient of the air pipe closing device and prepare the resistance characteristics curves (See Figure 5) according to measured volume flow and pressure drop. The coefficient may be calculated according to the following formula:

$$\zeta = \frac{2 \cdot \Delta P_v}{W^2 \cdot \rho}$$

$$W = \frac{V}{A}$$

where:  $\zeta$  – local resistance coefficient;

$\Delta P_v$  – pressure drop of closing device, in mbar;

$W$  – flow rate of test medium, in m/s;

$V$  – volume flow of test medium, in m<sup>3</sup>/h;

$A$  – sectional area of measured pipe section, in m<sup>2</sup>;

$\rho$  – specific gravity of test medium, in kg/m<sup>3</sup>.

#### 7.4.5 Pressure test and immersion/emerging tightness test

(1) Pressure test:

- ① Test method: remove the exit cover of the closing device and fit the blind plate. Fill the body with water and when the float is fully immersed in water, check whether bubbles burst out of the float; then apply a pressure of not less than 0.03 MPa twice for at least 5 min to the flange and exit blind plate respectively.
- ② Technical requirements: the body is free from leakage; open the upper cover and observe the surfaces of ball/float that contact the valve seat and the sealing surface is free from any linear leakage.

(2) Methods and technical requirements for immersion/emerging tightness test are specified in 1.4.1(2), Appendix 4, Chapter 2, PART THREE of CCS Rules for Classification of Sea-Going Steel Ships.

#### 7.4.6 Impact test and compression loading test of non-metallic balls/floats

Methods and technical requirements for such test are specified in 1.4.2, Appendix 4, Chapter 2, PART THREE of CCS Rules for Classification of Sea-Going Steel Ships.

#### 7.4.7 Impact test of metallic balls/floats

Methods and technical requirements for such test are specified in 1.4.3, Appendix 4, Chapter 2, PARTTHREE of CCS Rules for Classification of Sea-Going Steel Ships.

#### 7.4.8 Weather tightness test

(1) Inspection/test methods:

Hose testing is required to verify the tightness of the closing device, as defined in the minimum pressure in the hose, at least equal to 0.2MPa is to be applied at a maximum distance of 1.5m. The nozzle diameter is not to be less than 12mm;

(2) Technical requirements:

No leakage will be found for the closing device after the test.

#### [7.4.9 Discharge/reverse flow test](#)

[Methods and technical requirements for such test are specified in 1.4.1, Appendix 4, Chapter 2, PARTTHREE of CCS Rules for Classification of Sea-Going Steel Ships.](#)

## 8 Unit/batch inspection

8.1 The inspections for issuing CCS marine products certificates are to be carried out only for those products which have been satisfactorily inspected/tested by the manufacturer and are ready for delivery.

8.2 The unit/batch inspection items for manufacturers with CCS type approval are as follows.

(1) Tests are to be witnessed according to the approved inspection plan, covering at least:

- ① visual inspection;
- ② dimension check;
- ③ pressure test and immersion/emerging tightness test.

(2) The following documents are to be submitted to CCS Surveyor for review when applying for unit/batch inspection:

- ① raw material quality certificates of main components and parts or report of reexamination of their physical and chemical properties – body, floats and guide pillars;
- ② pressure/tightness test records of the body and float;
- ③ dimension check records – diameter, lift, float diameter and height;
- ④ routine performance inspection/test reports or records;
- ⑤ copies of calibration certificates of test instruments and meters, or a list of their calibration.

(3) At least 5% or one unit is to be selected randomly from each batch/for each specification and re-tested by the surveyor according to the above test items.

(4) The test report is to include product or sample type, specification, serial number, test location and date, test environment, test items, test data, problems revealed in the test and examination and description of how the problems are handled, and test conclusions.

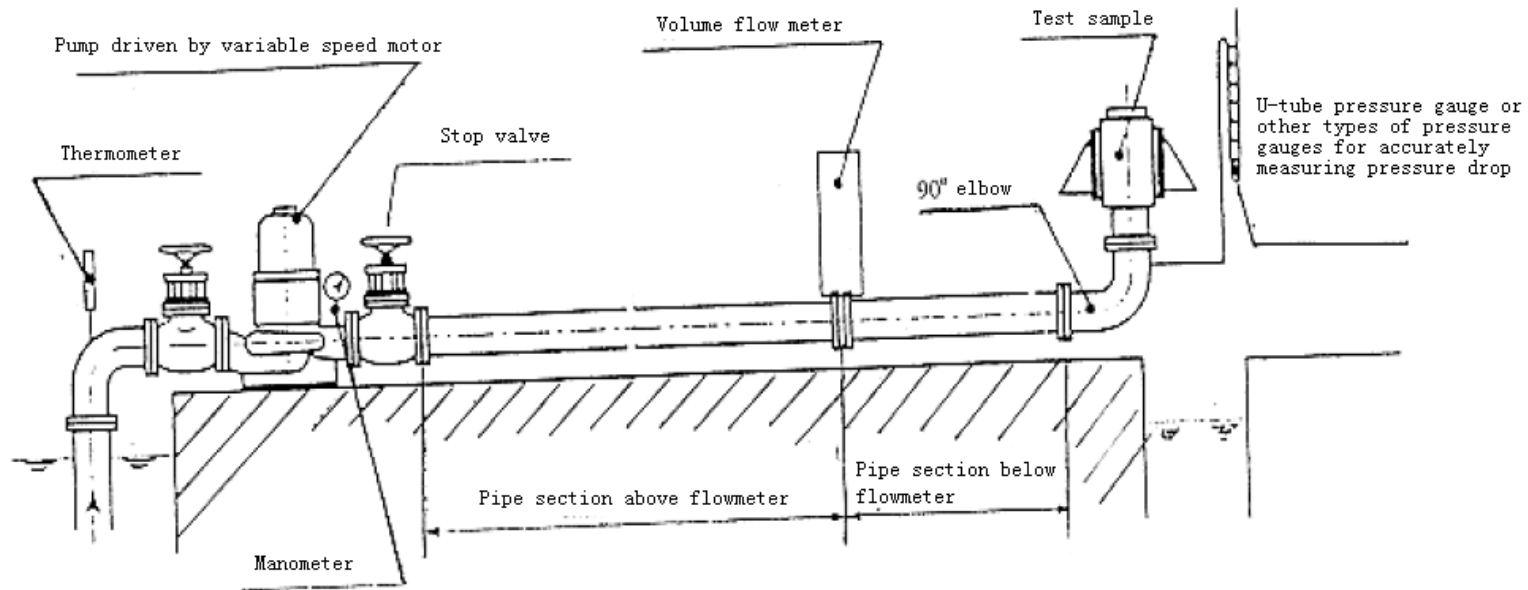

Figure 1

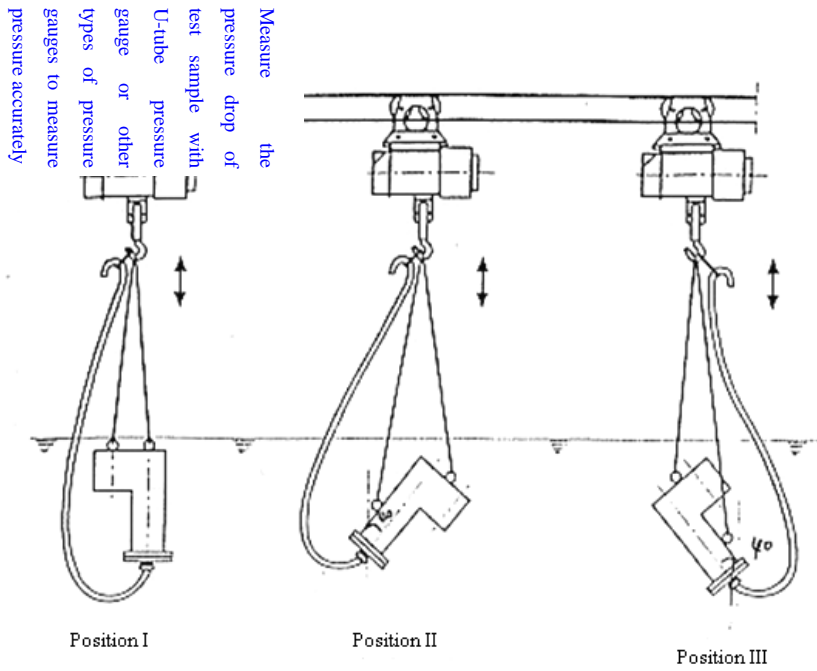

Figure 2

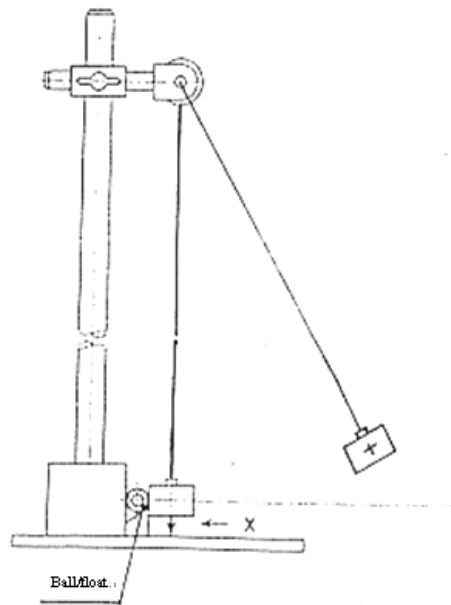

Figure 3

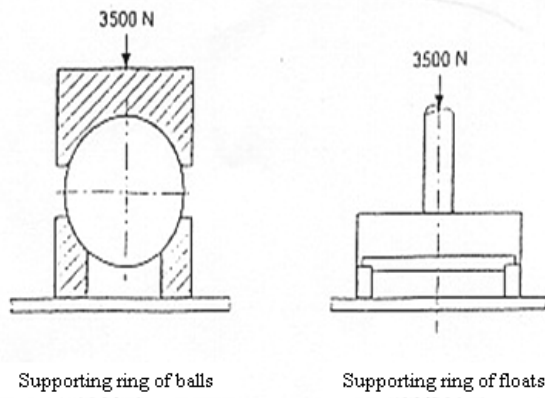

Figure 4

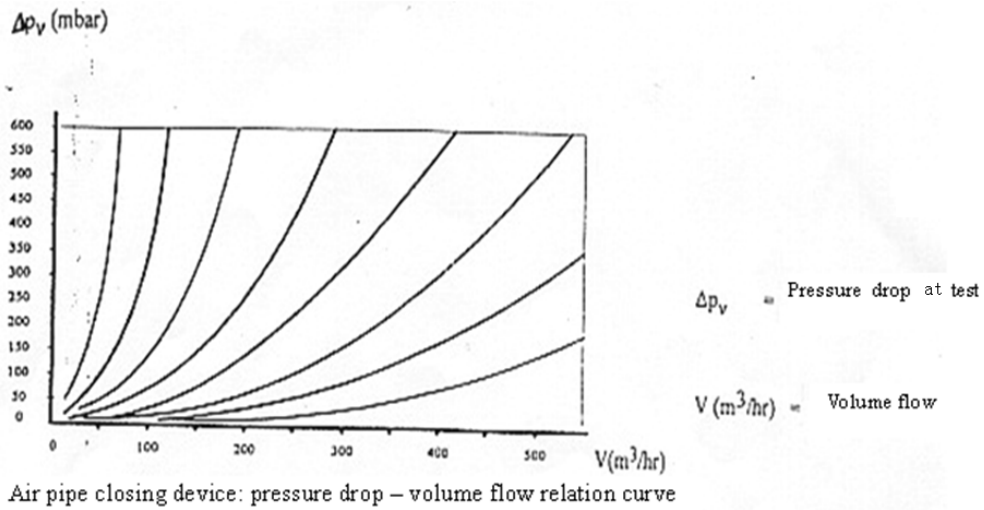

Figure 5