



Guideline No.: E-22(201712)

E-22

PRIMARY LITHIUM

BATTERY

Issued date: December 7, 2017

©China Classification Society

Foreword

CCS Product Inspection and Testing Guideline (hereinafter referred to as this Guideline) contains the technical requirements, inspection and testing criteria related to classification and statutory survey of marine products to be applied for CCS approval/inspection.

This Guideline frees the users to adopt other test methods and requirements which are equivalent to or are stricter than this Guideline.

This Guideline is published and updated by CCS, and is released at <http://www.ccs.org.cn>. Your comments or suggestions are welcomed and may be sent to our mail addressed mp@ccs.org.cn.

Historical release version and issuing date: E22(201712) December 7,2017

Main change: New Release

Contents

1. Scope of Application 4

2 Normative References 4

3 Definitions 4

4 Drawings and Documents 6

5 Design Requirements 7

6 Performance 13

7 Test 17

PRIMARY LITHIUM BATTERY

1. Scope of Application

1.1 The Guideline is applicable to primary lithium batteries (packs) for shipboard communication and other non-reserve batteries (hereinafter referred to as "batteries") and primary lithium cells (hereinafter referred to as "cells") which make up the batteries.

1.2 For the product certificate issued after inspection of primary lithium battery products, the batteries of EPIRB and two-way VHF equipment which are due and to be changed shall not be replaced with this primary lithium battery product unless it undergoes the type test on machine of the original equipment manufacturer.

2 Normative References

2.1 The approval and inspection criteria of primary lithium batteries are as follows:

2.1.1 IEC60086-1: 2015 Primary batteries-Part1: General

2.1.2 IEC60086-2: 2015 Primary batteries-Part2: Physical and electrical specifications

2.1.3 IEC60086-4:2014 Primary batteries-Part4: Safety of lithium batteries

3 Definitions

3.1 The relevant definitions of the Guideline are as follows:

3.1.1 Aggregate lithium content: The aggregate lithium content of all the cells contained in a battery;

3.1.2 Primary battery: The battery consisting of one or more primary cells and assembled with devices (e.g., cases, terminals, signs and protective devices) necessary for their use;

3.1.3 Primary cell: The basic functional unit of power supply which is designed to be non-rechargeable, directly converts chemical energy into electrical energy, and consists of electrodes, electrolyte, container, poles, and usually isolation layers.

3.1.4 Component cell: The cell which is contained in a battery;

3.1.5 Cylindrical cell: cylindrical cell, of which the overall height is equal to or greater than the diameter

3.1.6 Depth of discharge: percentage of capacity discharged from a battery in its normal capacity;

3.1.7 Full discharge: state of charge of a cell or battery at 100 % depth of discharge;

3.1.8 Intended use: Use of product, process or service in accordance with the information provided by the supplier;

3.1.9 Lithium cell: The non-aqueous electrolyte cell, of which the negative electrode is made of lithium or contains lithium;

3.1.10 Nominal voltage: A reasonable approximate value of voltage used to designate or identify a cell, a battery or an electrochemical system;

3.1.11 Open circuit voltage: voltage of battery in the case of no discharge current;

3.1.12 Leakage: unplanned escape of electrolyte, gas or other material from a cell or battery;

3.1.13 Protective devices: devices such as fuses, diodes or other electric or electronic current limiters designed to interrupt the current flow, block the current flow in one direction or limit the current flow in an electrical circuit

3.1.14 Rated capacity: capacity value of a cell or battery determined under specified conditions and declared by the manufacturer

3.1.15 Reasonably foreseeable misuse: use of a product, process or service in a way not intended by the supplier, but which may result from readily predictable human behaviour

3.1.16 Undischarged: state of charge of a cell or battery at 0 % depth of discharge

3.1.17 Storage life: duration of a battery under specified conditions at the end of which a battery retains the specified discharge capacity;

3.1.18 End-point voltage: the closed circuit voltage of a battery at which the battery discharge is terminated;

3.1.19 Closed circuit voltage: voltage across the terminals of a battery during discharging.

3.1.20 venting: The cell actuates the safety device and discharges gas or liquid under the internal pressure, but the case remains intact.

3.1.21 Reserve battery: Batteries which can be used after they are activated.

4 Drawings and Documents

4.1 When an application is made for approval, the following drawings and documents shall be submitted for approval:

4.1.1 General plot plan of cells / structural diagram of cells

4.1.2 Structural diagram of batteries (battery packs);

4.1.3 Wiring diagram of batteries (battery packs);

4.1.4 Product technical specifications;

4.1.5 Type test outline.

4.2 When an application is made for approval, the following drawings and documents shall be submitted for future reference:

4.2.1 Product nameplate and marking pattern;

4.2.2 Detailed list of main parts and materials of the product;

4.2.3 Main parts drawings of products;

4.2.4 Product operation manual;

4.2.5 Process flow chart of product manufacturing;

4.3 Other documents to be submitted:

4.3.1 Factory profile: Factory name, address, production history, production capacity, technology and inspection personnel, main products, affiliation, and trademarks, etc.;

4.3.2 Product details applying for approval;

4.3.3 List of suppliers;

4.3.4 Main production equipment;

4.3.5 Main inspection equipment;

4.3.6 Brief production process of products applying for approval;

4.3.7 Quality management documents;

4.3.8 Business registration certificate;

4.3.9 Qualification certificate and / or production license;

4.3.10 Sample of product quality certificate;

4.3.11 Quality control plan (if applicable).

5 Design Requirements

5.1 General

5.1.1 Design principles

When designing primary batteries, the following considerations shall be taken into account. Specifically, their dimensional conformity and stability, their physical and electrical performance and their safe operation under normal use and foreseeable mis-use conditions shall be assured.

批注 [M1]: 译文与原文表达的意思不一致。

The safety design of lithium batteries shall meet the requirements specified in Appendix A of IEC60086-4 2014 Primary batteries-Part 4: Safety of lithium batteries.

5.1.2 Classification (electrochemical system)

The classification of primary lithium batteries according to their electrochemical systems shall comply with Table 5.1.2.

The electrochemical systems that have been standardized up to now are given in Table 5.1.2.

Table 5.1.2 Standardized electrochemical systems

Letter	Negative electrode	Electrolyte	Positive electrode	Nominal voltage V	Maximum open circuit voltage V
B	Lithium (Li)	Organic electrolyte	Fluorocarbon polymer (CF) _x	3.0	3.7
C	Lithium (Li)	Organic electrolyte	Manganese dioxide (MnO ₂)	3.0	3.7

Table 5.1.2 (Continued)

E	Lithium (Li)	Nonaqueous inorganic substance	Thionyl chloride (SOCl ₂)	3.6	3.9
F	Lithium (Li)	Organic electrolyte	Iron disulfide (FeS ₂)	1.5	1.9
G	Lithium (Li)	Organic electrolyte	Copper oxide (II) (CuO)	1.5	2.3
W	Lithium (Li)	Organic electrolyte	Sulfur dioxide (SO ₂)	2.9	3.05
Y	Lithium (Li)	Nonaqueous inorganic substance	Sulfuryl chloride (SO ₂ Cl ₂)	3.9	4.1

5.1.3 Designation The designation of primary batteries is based on their physical parameters and their electrochemical system, as well as modifiers, if needed.

For comprehensive explanation of the designation system (nomenclature), refer to Annex C of IEC60086-1:2015.5.2 Materials

5.2.1 Metals

All metals that do not participate in the basic electrochemical reaction of the batteries shall be corrosion resistant or shall be corrosion resistant after treatment.

5.2.2 Materials of the case

Unless otherwise specified in the design, the battery case shall be made of non-flammable plastic. HB grade plastic materials in UL94-2001 are recommended.

5.2.3 Insulation, impregnation, filling and sealing materials

When tested in accordance with 7.7.9.11, materials used for insulation, impregnation, filling and sealing shall not flow at 93°C and shall not crack nor peel off from the container walls at -40°C. Any material used shall be non-flammable and non-toxic. Materials shall not limit the movement of the safety device of the batteries.

5.2.4 Insulation materials of leads and connecting sheets

Unless otherwise specified in the design, all leads and connecting sheets connected electrically between the cells and the batteries shall be covered with insulating materials, which shall have the following characteristics:

- a) Minimum softening temperature: 150°C;
- b) Maximum longitudinal shrinkage ratio: 3%;
- c) Minimum thickness: 0.127mm;

Materials shall be non-flammable and non-toxic, and do not penetrate the battery electrolyte.

5.3 Design and structure

5.3.1 Battery design

(1) The pattern, structure, physical dimensions, weight and terminals type of batteries shall comply with the design requirements. Batteries shall not adopt the structure mode of cells connected in parallel; when connection in parallel is required, protective devices in prevention of charging shall be adopted.

(2) The safety of batteries varies greatly due to different lithium systems, different capacities and different battery structures. During the battery

design, safety issues in all aspects must be taken into consideration; the safety design of lithium batteries shall focus on the following aspects:

- ① Preventing abnormal temperature increase and avoiding exceeding the critical value specified by the manufacturer through the design;
- ② Controlling temperature increase of the batteries through the design of the current limit;
- ③ Lithium batteries shall be designed to relieve their excessive internal pressure or to preclude serious rupture in shipping, intended use and reasonably foreseeable misuse.

5.3.2 Battery assembly

Batteries shall be assembled in accordance with the procedures specified by the manufacturer. The process shall ensure that the internal conductors of batteries are insulated from each other to prevent or avoid short circuits between the cells in the batteries.

5.4 Appearance

The surface of batteries shall be smooth and clean, free of any obvious damage and deformation.

5.5 Size and weight

The battery size shall meet the requirements of IEC60086-2: 2015 Primary batteries-Part 2: Physical and electrical specifications. The weight of batteries shall meet the design specification.

5.6 Color

When definite requirements are imposed on the appearance color of the equipment, the color of the batteries which power up the equipment shall meet the requirements.

5.7 Terminals type

5.7.1 General

The terminals shall comply with the requirements in Article 6 of IEC60086-2: 2015 Primary batteries-Part 2: Physical and electrical specifications.

The shape of terminals shall be designed to ensure that the batteries have a good contact at any time.

The terminals shall be made of a material that has the appropriate conductivity and corrosion resistance.

The signs of the terminals shall clearly indicate the polarity.

5.7.2 Contact pressure resistance

When 10N force is applied on the center of each contact surface of batteries for 10s through a steel ball with the diameter of 1mm, no significant deformation which may cause interference with the normal operation of batteries shall occur.

5.7.3 Terminals type

(1) Cap and base

This type of terminal is used for batteries which have their dimensions specified according to Figures 1 to 7 of IEC 60086-2:2015 and which have the cylindrical side of the battery insulated from the terminals.

批注 [M2]: 译文与原文表达的意思不一致

(2) Cap and case
This type of terminal is used for batteries which have their dimensions specified according to Figures 8, 9, 10, 14, 15 and 16 of IEC 60086-2: 2015, but in which the cylindrical side of the battery forms part of the positive terminal.

批注 [M3]: 译文与原文表达的意思不一致

(3) Screw terminals
This contact consists of a threaded rod in combination with either a metal or insulated metal nut.

(4) Flat contacts
These are essentially flat metal surfaces adapted to make electrical contact by suitable contact mechanisms bearing against them.

(5) Flat or spiral springs
These contacts comprise flat metal strips or spirally wound wires which are in a form that provides pressure contact.

(6) Plug-in-sockets
These are made up of a suitable assembly of metal contacts, mounted in an insulated housing or holding device and adapted to receive corresponding pins of a mating plug.

(7) Snap fasteners
These contacts are composed of a combination comprising a stud (non-resilient) for the positive terminal and a socket (resilient) for the negative terminal.

They shall be of suitable metal so as to provide efficient electrical connection when joined to the corresponding parts of an external circuit. The size and spacing of stud and socket shall meet the relevant standards.

5.7.4 Wire leads

Wire leads may be single or multi-strand flexible insulated tinned copper. The insulation layer of leads may be a cotton braid or an appropriate plastic. The positive terminal wire covering shall be red and the negative black.

5.7.5 Other spring contacts or clips

These contacts are generally used on batteries when the corresponding parts of the external circuit are not precisely known. They shall be of spring brass or of other material having similar properties. 5.8 Marking and nameplates

5.8.1 Battery marking

With the exception of small batteries (see 5.8.2), each battery shall be marked with the following information::

- a) Designation;
- b) Expiration of a recommended usage period, or year and month or week of manufacture. The year and month or week of manufacture may be in code;
- c) polarity of the positive (+) terminal;
- d) Nominal voltage;
- e) name or trade mark of the manufacturer or supplier;
- f) Trademarks
- g) Executive standard No.;
- h) Safety precautions (warning instructions);
- i) Mercury content ("low mercury" or "mercury-free") (where applicable);

批注 [M4]: 译文与原文意思不同

The location of the signs is shown in Table 5.8.2.

5.8.2 Marking of small batteries

(1) Batteries designated in the IEC60086-2 as small, mainly category 6.3 and category 6.4 batteries have a surface too small to accommodate all markings shown in 5.8.1.1. For these batteries the designation specified in 5.8.1.1a) and the polarity symbol specified in 5.8.1.1c) shall be marked on the battery. All other markings shown in 5.8.1.1 may be given on the immediate packing instead of on the battery.

(2) Caution for ingestion of swallowable batteries shall be given.. Refer to IEC60086-4 for details.

批注 [M5]: 此处译文与原文有差异, 原文为

- e)→标称容量; ..
- f)→制造厂或供应商的名称和地址
- g)→商标; ..
- h)→执行标准编号; ..
- i)→安全使用注意事项(警告说明)
- j)→含汞量("低汞"或"无汞")(只适用于可充电电池)

Table 5.8.2 Marking requirements

Markings	Batteries	Small batteries
a) Designation	A	A
b) Expiration of a recommended usage period or year and month or week of manufacture. The year and month or week of manufacture may be in code	A	B

批注 [M6]: 译文与原文意思不一致

E-22 (201712) PRIMARY LITHIUM BATTERY

c) Polarity of the positive (+) terminal	A	A
d) Nominal voltage	A	B
e) Name and address of the manufacturer or supplier	A	B
f) Trademarks	A	B
g) Executive standard No.	A	B
h) Safety precautions (warning instructions)	A	B
i) Mercury content ("low mercury" or "mercury-free") (where applicable)	A	B
<p>A: shall be marked on the battery. B: may be marked on the immediate packing instead on the battery. C: may be marked on the battery, the sealing tape or the immediate packing D: may be marked on the sealing tape and/or on the battery.</p>		
<p>Caution for ingestion of swallowable batteries shall be given.. Refer to IEC 60086-4:2014 7.2 and 9.2 for details.</p>		

5.8.3 Marking of batteries regarding method of disposal Marking of batteries with respect to the method of disposal shall be in accordance with Chinese legal requirements..

5.8.4 Marking of terminals

When the batteries adopt the terminals in the form of a connector, all marks shall be on the same surface as the connector. As for other forms of terminals, the marks of terminals can be on surfaces or sides, or on both sides of the terminals. Marks shall clearly indicate polarity of the terminals.

5.8.5 Clarity and durability

After the batteries have been subjected to the relevant environmental tests of this code, the marking and nameplates shall be clearly and completely indicated. The color of the signs and nameplates shall be distinguishable from the background. When the nameplates and signs are etched or embossed, the color of the text can be the same as the background.

5.9 Insulation resistance

Unless otherwise specified in the design, the batteries shall have an insulation resistance of not less than 50 MΩ when measured in accordance with 7.7.5.

5.10 Moisture content of cells

The moisture content of cells shall meet the design requirements.

5.11 Storage life

Storage life of the batteries shall meet the requirements of following:

a) The batteries are tested in accordance with 7.7.9.14 a). After the storage, the batteries shall not be subjected to expansion, deflation, leakage, rupture or combustion. For fully sealed batteries; after the storage, the room-temperature discharge capacity shall not be less than 95% of the rated capacity; and the low-temperature discharge capacity and high-temperature discharge capacity shall meet the design requirements; For mechanically sealed batteries, the room-temperature discharge capacity/ low-temperature discharge capacity and high-temperature discharge capacity (after the storage) shall meet the design requirements.

b) The batteries shall be tested according to 7.7.9.14b), and the manufacturer shall ensure (or prove) that the room-temperature discharge capacity of the fully sealed batteries after 5 years of storage shall not be less than 90% of the rated capacity; the room-temperature discharge capacity of mechanically sealed batteries after 5 years of storage shall meet the design requirements.

6 Performance

6.1 Discharge performance

Discharge performance of primary batteries is specified in IEC 60086-2: 2015.

6.2 Dimensional stability

The dimensions of batteries shall conform with that given in IEC 60086-2 :2015 at all times during testing under the standard conditions given in this specification..

6.3 Leakage

6.3.1

When batteries are stored and discharged under the standard conditions given in this specification, no leakage shall occur..

6.3.2 When the cells are tested according to 7.7.9.11, no leakage shall occur during the test period of 7 days. The leakage of the fully sealed batteries after the test shall not exceed 0.005% of the total weight of the electrolyte while that of the mechanically sealed cell shall not exceed 1% of the total weight of the electrolyte.

6.4 Voltage

6.4.1 Open circuit voltage

(1) Open circuit voltage of batteries

When measured according to 7.7.6.1.1, the maximum open circuit voltage of the battery shall comply with the design requirements.

(2) Open circuit voltage of cells

When measured according to 7.7.6.1.2, the maximum open circuit voltage of cells shall comply with the design requirements.

6.4.2 Load voltage

(1) Load voltage of batteries

When measured according to 7.7.6.2.1, the voltage value of batteries shall rise to the end-point voltage specified in the design within 10s.

(2) Load voltage of cells

When measured according to 7.7.6.2.2, the voltage value of cells shall rise to the end-point voltage specified in the design within 5s.

6.5 Capacity

6.5.1 The discharge time during the initial period and storage period of the battery shall meet the design requirements, and shall be at least not lower than the requirements of IEC 60086-2.

For service output tests, the load resistor with reasonable ohmic value should be selected such that the service output approximates 30 days. When full capacity is not realized within the required time scale, the service output may be extended to the shortest suitable duration thereafter by selecting a load resistor of higher ohmic value.

When the batteries are tested according to 7.7.7.2.2, the discharge time shall be calculated when the battery voltage reaches the lagged value of the initial voltage, and the batteries shall not have any of the following cases.

- a) The discharge time of batteries is less than the time of minimum discharge capacity specified in the design;
- b) The batteries are disconnected before the end of the test;
- c) The lag time of initial voltage exceeds the specified time (see 6.5.2);
- d) The battery size is out of tolerance after discharge;
- e) The batteries are subjected to expansion, deflation, leakage, rupture or combustion at any time after they have been lay aside, tested or they have discharged;

Note: The room-temperature discharge capacity of batteries specified by the design shall not be less than the marked rated capacity.

6.5.2 Lagging of initial voltage

When the batteries are tested according to 7.7.7.2.1, the time it takes for the voltage to rise to the lagging value of the initial voltage specified in the design after the load is connected shall not exceed the design value.

6.6 Environmental adaptability

6.6.1 Vibration

When the batteries are tested according to 7.7.8.1, the batteries shall not be subjected to mass loss, leakage, venting, short circuit, rupture, explosion, or fire during the test.

6.6.2 Shock

When the batteries are tested according to 7.7.8.2, the batteries shall not be subjected to mass loss, leakage, venting, short circuit, rupture, explosion, or fire during the test.

6.6.3 Free fall

When the batteries are tested according to 7.7.8.3, the batteries shall not be subjected to venting, explosion, or fire during the test and during the observation period of 1 hour after the test.

6.6.4 High-altitude simulation

When the batteries are tested according to 7.7.8.4, the batteries shall not be subjected to mass loss, leakage, venting, short circuit, rupture, explosion, or fire during the test.

6.6.5 Thermal shock

When the batteries are tested according to 7.7.8.5, the batteries shall not be subjected to mass loss, leakage, venting, short circuit, rupture, explosion, or fire during the test.

6.6.6 Thermal abuse

When the batteries are tested according to 7.7.8.6, the batteries shall not be subjected to explosion or fire during the test.

6.7 Safety

6.7.1 Safety device of cells

When designing primary batteries, safety under conditions of intended use and foreseeable mis-use as prescribed in IEC 60086-4:2014 shall be considered..

The case of cell shall be provided with a safety device. When the cell is tested in accordance with 7.7.9.1, the safety device shall not operate and the case shall be sealed when the case is subjected to an internal pressure equivalent to a temperature range of below 96°C; the safety device shall operate to avoid combustion or explosion of the cell when the case is subjected to an internal pressure equivalent to a temperature range of 96°C

~149°C. The pressure applied during the test shall be specified by the manufacturer.

6.7.2 Heating of cells

When the cells are tested according to 7.7.9.2, the safety device shall not operate and the cells shall be sealed when the cells are subjected to temperature of 90°C; the safety device shall operate and the cells shall venting when the cells are subjected to temperature of 149°C.

6.7.3 Short circuit of cells

When the cells are tested according to 7.7.9.3, the cells shall not be subjected to explosion or fire during the test and during the observation period of 6h after the test.

6.7.4 Forced discharge of cells

When the cells are tested according to 7.7.9.4, the cells shall not be subjected to deflation, leakage, rupture or fire during the test and during the observation period of 7 days after the test.

6.7.5 External short circuit of batteries

When the batteries are tested according to 7.7.9.5, the batteries shall not be subjected to overheating, rupture, explosion or fire during the test and during the observation period of 6 hours after the test.

6.7.6 Crush

When the batteries are tested according to 7.7.9.7, the batteries shall not be subjected to excessive temperature rise, explosion or fire during the test and during the observation period of 6 hours after the test.

6.7.7 Forced discharge of the battery

When the batteries are tested according to 7.7.9.4, the batteries shall not be subjected to explosion or fire during the test and during the observation period of 7 days after the test.

6.7.8 Abnormal charging

When the batteries are tested according to 7.7.9.9, the batteries shall not be subjected to explosion or fire during the test.

6.7.9 Overdischarge of batteries

When the batteries are tested according to 7.7.9.6, the batteries shall not be subjected to explosion or fire during the test.

6.7.10 Incorrect installation of batteries

When the batteries are tested according to 7.7.9.10, the batteries shall not be subjected to explosion or fire during the test.

6.7.11 Impact of heavy objects

When the batteries are tested according to 7.7.9.8, the batteries shall not be subjected to excessive temperature rise, explosion or fire during the test and during the observation period of 6 hours after the test.

7 Test

7.1 General

Testing methods of lithium battery products are recommended to be formulated with reference to Standard Methods of Measuring Performance (SMMP) of Consumer Goods.

7.2 Judgment standards of test results

7.2.1 Short circuit

A short-circuit is considered to have occurred during a test if the open-circuit voltage of the cell or battery immediately after the test is less than 90 % of its voltage prior to the test.

This requirement is not applicable to test cells and batteries in fully discharged states.

7.2.2 Excessive temperature rise

An excessive temperature rise is considered to have occurred during a test if the external case temperature of the test cell or battery rises above 170 °C.

7.2.3 Leakage

Leakage is considered to have occurred during a test if electrolyte, gas or other material escapes from the test cell or battery in a manner not intended by design.

7.2.4 Mass loss

Mass loss is considered to have occurred if, during a test, the maximum values given in Table 7.2.4 are exceeded.

In order to quantify mass loss $\Delta m / m$, the following equation is provided:

$$\Delta m / m = (m - m_1) / m \times 100\%$$

where:

m – the mass before a test

m_1 – the mass after a test

Table 7.2.4 Maximum limit of mass loss

Mass of battery m	Maximum limit of mass loss $(\Delta m/m)\%$
$m \leq 1g$	0.5
$1g < m \leq 75g$	0.2

m > 75g	0.1
---------	-----

7.2.5 Venting

Venting is considered to have occurred if, during a test, an excessive buildup of internal gas pressure escapes from a cell or battery through a safety feature designed for this purpose. This gas may include entrapped materials.

A fire is considered to have occurred if, during a test, flames are emitted from the test cell or battery.

7.2.7 Rupture

A rupture is considered to have occurred if, during a test, a cell container or battery case has mechanically failed, resulting in expulsion of gas, spillage of liquids, or ejection of solid materials but no explosion.

An explosion is considered to have occurred if, during a test, solid matter from any part of a cell or battery has penetrated a wire mesh screen as shown in Figure 7.2.8, centred over the cell or battery on the steel plate. The screen shall be made from annealed aluminium wire with a diameter of 0,25 mm and a grid density of 6 to 7 wires per cm.

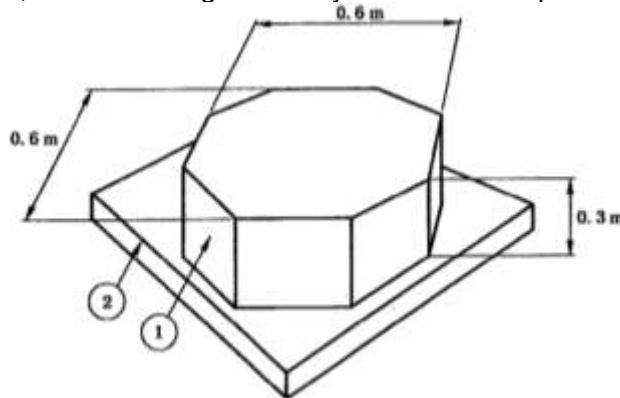

Figure 7.2.8 Diagram of mesh screen

- ①- Octagonal mesh screen of aluminum wire
- ②- Steel plate

7.2.9 Expansion

An expansion is considered to have occurred if, during a test, the batteries expand outward due to internal pressure, which leads to obvious deformation.

7.3 Test classification

The test classification is as follows:

a) Type test

b) Single batch test

7.4 Test conditions

Unless otherwise specified, all tests shall be conducted under the following conditions:

a) Ambient temperature: 20 ± 2 °C;

b) Relative humidity: $55\% \pm 20\%$;

c) Atmospheric pressure on the test site

7.5 Measuring instruments and test equipment

7.5.1 General

Measuring instruments and test equipment shall meet the test requirements in accuracy, quantity and quality. All instruments and equipment shall be accredited or metered to be up to standard according to relevant national metrological verification regulations or relevant standards and shall be within the validity period.

7.5.2 Voltage measurement

The accuracy of the measuring equipment shall be $\leq 0,25$ % and the precision shall be $\leq 50\%$ of the value of the last significant digit. The internal resistance of the measuring equipment shall be ≥ 1 M Ω .

7.5.3 Resistance

With resistance as load, the resistance of all measuring instruments working continuously and the leads shall also be counted as the load. The difference between the resistance and the specified value shall not exceed $\pm 0.5\%$.

7.5.4 Power supply

The accuracy of power supply used in the discharge test shall be within $\pm 1\%$.

7.5.5 Timer

When the measurement time is longer than 120s, the accuracy of the timer shall be within 0.1%; otherwise, the accuracy of the timer shall be within 0.5%.

7.5.6 Dimensions

The accuracy of the measured dimension shall be within $\pm 1\%$.

7.6 Type test

Type test includes type test of cells and type test of batteries.

Type test of batteries includes conventional / electrical performance test and safety type test.

If the applicant applies for type approval of multiple models of primary batteries at a time, in principle, a representative battery can be chosen as the sample of type test for the relevant tests. The test shall be carried out in an accredited institution or laboratory. Samples of the type test shall be products manufactured with materials, equipment and processes usually used during the normal production.

7.6.1 Type test of cells

(1) Type test items of cells and sampling principles

The samples used for type test of cells shall be products manufactured with materials, equipment and processes usually used during the normal production and shall be randomly selected. The items, sequence and sample size of the test shall be as shown in Table 7.6.1.

Table 7.6.1 Items of type test of cells

S/N	Test item	No. of required article	No. of test method	Sample size
1	Open circuit voltage of cells	6.4.1	7.7.6.1.2	20
2	Load voltage of cells	6.4.2	7.7.6.2.2	20
3	Leakage of cells	6.3.2	7.7.9.12	20
4	Heating of cells	6.7.2	7.7.9.2	5
5	Short circuit of cells	6.7.3	7.7.9.3	5
6	Forced discharge of cells	6.7.4	7.7.9.4	2c

Table 7.6.1 (Continued)

7	Safety device of cells	6.7.1	7.7.9.1	5 cases of cells
8	Insulation, impregnation, filling and sealing materials	5.2.3	7.7.9.11	Once each batch
9	Moisture content of cells	5.10	7.7.9.13	Confirmed through consultation ^a

Note: "c" is the number of cells connected in parallel in a battery, while 2c cells are divided into two battery strings for testing according to the requirements of 4.7.9.

^aThe test timing and test scope of cell moisture content shall be confirmed through consultation between the manufacturer and the ordering party.

(2) Qualification evaluation of type test of cells

When the test item of any cell cannot meet the requirements, the sample test shall be deemed as unqualified. The producer shall identify the cause

and take corrective actions. After corrective actions are taken, sampling test can be conducted once again. If the sampling test fails again, it is determined that the type test of cells fails, and it is not allowed to re-test.

7.6.2 Type test of batteries

Type test of batteries includes electrical performance / conventional test and safety test, which shall be conducted by sampling separately. Samples of the type test shall be products manufactured with materials, equipment and processes usually used during the normal production. And the cells used by the batteries are qualified through production inspection.

(1) Electrical performance / conventional type test

The items and sequence of electrical performance / conventional tests are as shown in Table 7.6.2.

Table 7.6.2 Items of electrical performance / conventional tests

S/N	Test item	No. of required article	No. of test sample
Appearance, marking and nameplates	5.4; 5.8	7.7.1	9
Color	5.6.1	7.7.3	
Terminals form	5.7	7.7.4	
Open circuit voltage of batteries	6.4.1.1	7.7.6.1.1	
Load voltage of batteries	6.4.2.1	7.7.6.2.1	
Insulation resistance	5.9.1	7.7.5	
Dimension and weight	5.5	7.7.2.1; 7.7.2.2	
Room-temperature capacity	6.5	7.7.7.2.2	
Minimum average discharge time	6.5	7.7.7.2.2	9
Storage life	5.11	7.7.9.14	6

(2) Safety type test

① Test sample

The number of samples to be tested is as shown in Table 7.6.2 (1) ①. The same samples are tested in order from item A to item E. New batteries are used for each test item from item F to item M.

Table 7.6.2 (1) ① Number of battery samples (safety test)

	Cells and batteries consisting of a cell	Batteries consisting of multiple cells

E-22 (201712) PRIMARY LITHIUM BATTERY

Number of sample for Items A~E	Undischarged	Fully discharged	Undischarged	Fully discharged
	10	10	4 ^a	4 ^a
Number of sample for items F~G	Undischarged	Fully discharged	The test does not apply to the battery. However, the cell shall pass the test in advance.	
	5 (coin cells and cylindrical cells) 10 (rectangular cells)	5 (coin cells and cylindrical cells) 10 (rectangular cells)		
Number of sample for item H	Undischarged	Fully discharged	The test does not apply to the battery. However, the cell shall pass the test in advance	
	NA	10		
Number of sample for items I ~ K	Undischarged	Fully discharged	Undischarged	Fully discharged
	5	NA	5	NA
Number of sample for item L	Undischarged	Fully discharged	NA	
	5 (+15) ^b	NA		
Number of sample for item M	Depth of discharge of 50%	Depth of discharge of 75%	NA	
	5 (+15) ^b	5 (+15) ^b		
<p>^aWhen batteries are tested, the number of tested batteries shall be determined as follows unless their cells or batteries consisting of these cells have passed the test in advance: the number of cells contained in these batteries shall be at least equal to the number of cells required by the test item.</p> <p>Example 1: If a battery containing 2 cells is tested, then the number of batteries required for the test is 5; and if the cells or batteries consisting of the cells have passed the test in advance, then the number of tested batteries is 4 .</p> <p>Example 2: If the battery containing 3 or more cells is tested, the number of batteries required for the test is 4.</p> <p>^b In the brackets are undischarged additional batteries.</p>				

② Items of safety type test

See Table 7.6.2 (1) ② for items of safety type test

Table 7.6.2 (1) ② Items of safety type test

Item No.	Test item	Clauses requirements	of	Clauses of test method
A	High-altitude simulation	6.6.4		7.7.8.4
B	Thermal shock	6.6.5		7.7.8.5
C	Vibration	6.6.1		7.7.8.1

E-22 (201712) PRIMARY LITHIUM BATTERY

D	Shock	6.6.2	7.7.8.2
E	External short circuit	6.7.5	7.7.9.5
F	Impact of heavy objects	6.7.11	7.7.9.8
G	Crush	6.7.6	7.7.9.7
H	Forced discharge	6.7.7	7.7.9.4
I	Abnormal charging	6.7.8	7.7.9.9
J	Free fall	6.6.3	7.7.8.3
K	Thermal abuse	6.6.6	7.7.8.6
L	Incorrect installation	6.7.10	7.7.9.10
M	Overdischarge	6.7.9	7.7.9.6

Note: Only one test shall be applied, test F or test G.7.7 Test method

7.7.1 Appearance, signs and nameplates

The battery's appearance, signs and nameplates shall be visually inspected, and shall meet the requirements of 5.4 and 5.8.

7.7.2 Size and weight

(1) Size

The measuring instruments with appropriate range and accuracy shall be adopted to measure the battery size, which shall comply with the requirements of 5.5. If the cartridge gauge is adopted, the gauge size shall be the specified maximum size of the batteries; when applied with the weight of 2.3kg at most, the batteries shall be able to successfully pass the corresponding gauge mouth; as to cylindrical batteries, go gauge meeting the above-mentioned requirements can be used for measurement.

(2) Weight

The measuring instruments with appropriate range and accuracy shall be adopted to measure the battery weight, which shall comply with the requirements of 5.5.1.

7.7.3 Color

The color of the batteries shall be visually inspected and shall meet the requirements of 5.6.1.

7.7.4 Terminals form

The terminals form shall be inspected visually or inspected with appropriate measuring instruments, and shall meet the requirements of 5.7

7.7.5 Insulation resistance

The insulation resistance is measured by applying a 500V ± 20V DC voltage between any two terminals of batteries free of electrical connection

and between any one of the terminals and the ground or battery case. When the insulation resistance of batteries with a non-metallic case is measured, a suitably sized copper plate shall be used to come into physical contact with the case. The copper plate shall be placed anywhere on one side of batteries without terminals, and shall be in close contact with the battery surface. The battery insulation shall meet the requirements of 5.9.1.

7.7.6 Voltage

(1) Open circuit voltage

① Open circuit voltage of batteries

The open circuit voltage of batteries shall be measured with a DC voltmeter which has an appropriate range and meets the requirements of 7.4.2, and shall comply with the requirements of 6.4.1.

② Open circuit voltage of cells

The open circuit voltage of cells shall be measured with a DC voltmeter which has an appropriate range and meets the requirements of 7.4.2, and shall comply with the requirements of 6.4.1.

(2) Load voltage

① Load voltage of batteries

After the design load is imposed on the batteries and the batteries discharge for 10s, the voltage of batteries shall be measured with a DC voltmeter which has an appropriate range and meets the requirements of 7.4.2, and shall comply with the requirements of 6.4.2.

② Load voltage of cells

After the design load is imposed on cells and the cells discharge for 5s, the voltage of cells shall be measured with a DC voltmeter which has an appropriate range and meets the requirements of 7.4.2, and shall comply with the requirements of 6.4.2.

7.7.7 Capacity

(1) Test requirements

During the capacity test, when the batteries are lay aside and before the discharge test begins, no load shall be applied while the load applied during the discharge shall be given according to the design requirements. The batteries start to discharge when the specified discharge environment gets stable. During the test, the ambient temperature should be continuously recorded to ensure its accuracy. During the discharge, an interval of 50mm shall be maintained between all batteries. If the batteries have a charge status indicator, it shall be checked whether the indicator indicates on the lowest gear after each capacity test. Batteries shall be subjected to the

tests of such items specified in 6.5.1 d), 6.5.1 e), and 6.5.1 f) within 24 hours after the end of discharge.

(2) Capacity test

① Lagging of initial voltage

At the start of discharge test in the capacity test, each battery shall be monitored in second as max timing unit, so as to measure the time it takes for the voltage to rise to the end-point voltage specified in the design after the specified load has been applied. The lagging time of initial voltage of the battery shall comply with the requirements of 6.5.2.

② Room-temperature capacity / minimum average discharge time

In order to verify the compliance of discharge performance of the battery, any application test or discharge capacity test as specified in IEC 60086-2 may be selected. The calculation method of the minimum average discharge time is shown in Appendix D of IEC 60086-2.

The test shall be carried out as follows:

- a) Test 9 batteries;
- b) Calculate the average without the exclusion of any result;
- c) If this average is equal to or greater than the specified value and no more than one battery has a service output of less than 80 % of the specified value, the batteries are considered to conform to service output.;
- d) If this average is less than the specified value and/or more than one battery has a service output of less than 80 % of the specified value, repeat the test on another 9 battery samples and calculate the average as previously.
- e) If the average of this second test is equal to or greater than the specified value and no more than one battery has a service output of less than 80 % of the specified value, the batteries are considered to conform to service output. ;
- f) If the average of the second test is less than the specified value and/or more than one battery has a service output of less than 80 % of the specified value, the batteries are considered not to conform and no further testing is permitted..

Note: Discharge performance of primary batteries is specified in IEC 60086-2..

Test results shall comply with the requirements of 6.5.1.

7.7.8 Environmental adaptability

(1) Vibration

Test cells and batteries shall be firmly secured to the platform of the vibration machine without distorting them and in such a manner as to faithfully transmit the vibration. Test cells and batteries shall be subjected to sinusoidal vibration according to Table 7.7.8 (1) which shows a different upper acceleration amplitude for large batteries. This cycle shall be repeated 12 times for a total of 3 h for each of three mutually perpendicular mounting positions. One of the directions shall be perpendicular to the terminal face.

The batteries which are subjected to thermal shock test are used in this test.

The test results shall comply with the requirements of 6.6.1.

Table 7.7.8 (1) Vibration profile (sinusoidal)

Frequency range		Amplitudes	Duration of logarithmic sweep cycle (7 Hz – 200 Hz – 7 Hz)	Axial direction	Number of cycles
From	To				

Table 7.7.8 (1) (Continued)

$f_1=7\text{Hz}$	f_2	$a_1=1g_n$	15min	X	12
f_2	f_3	$s=0.8\text{mm}$		Y	12
f_3	$f_4=200\text{Hz}$	a_2		Z	12
and back to $f_1 = 7 \text{ Hz}$				Total	36

Note: Vibration amplitude is the maximum absolute value of displacement or acceleration. For example, a displacement amplitude of 0,8 mm corresponds to a peak-to-peak displacement of 1,6 mm.

Key:

f_1, f_4 - lower and upper frequency f_2, f_3 - cross-over frequencies; ($f_2 \approx 17.62\text{Hz}$, $f_3 \approx 49.84\text{Hz}$, except for large batteries, where $f_3 \approx 24,92 \text{ Hz}$)

a_1, a_2 - Acceleration amplitude

$a_2 = 8 g_n$ except for large batteries, where $a_2 = 2 g_n$

s- Displacement amplitude

批注 [M7]: 原文中没有此类容

批注 [M8]: 原文中没有此类容

(2) Shock

The test shall be conducted using the test cells and batteries previously subjected to the vibration test. Both the undischarged and fully discharged batteries shall be subjected to shock test.

Test cells and batteries shall be secured to the testing machine by means of a rigid mount which will support all mounting surfaces of each test cell or battery. Each test cell or battery shall be subjected to 3 shocks in each direction of three mutually perpendicular mounting positions of the cell or battery for a total of 18 shocks. For each shock, the parameters given in Table 7.7.8 (2) shall be applied.

Table 7.7.8 (1) Shock parameters

E-22 (201712) PRIMARY LITHIUM BATTERY

Battery type	Waveform	Peak acceleration	Pulse duration	Number of shocks per half axis
Cells or batteries except large ones	Half sine	150g _n	6ms	3
Large cells or batteries	Half sine	50g _n	11ms	3
Note: g _n = 9,80665 m / s ²				

The test results shall comply with the requirements of 6.6.2.

(3) Free drop

The tested batteries are dropped from a height of 1m onto a concrete surface.

Each test battery shall be dropped six times at 1m to the concrete floor. The rectangular test battery shall be dropped once with each surface downward respectively and a round battery shall be dropped twice in each of the three axes. The test batteries shall be stored for 1h afterwards.

The test shall be conducted with undischarged test cells and batteries.

The test results shall comply with the requirements of 6.6.3.

(4) High-altitude simulation

Test cells and batteries shall be stored at a pressure of 11.6 kPa or less for at least 6 h at ambient temperature. The test results shall comply with the requirements of 6.6.4.

(5) Thermal shock

Test cells and batteries shall be stored for at least 6 h at a test temperature of 75 °C, followed by storage for at least 6 h at a test temperature of -40 °C. The maximum time for transfer to each temperature shall be 30 min. The procedure shall be repeated 10 times for the same cell or battery, which will be held for at least 24 h at ambient temperature.

For large cells and batteries, the duration of exposure to the test temperatures shall be at least 12h instead of 6h. The test shall be conducted

using the test cells and batteries previously subjected to the altitude test.

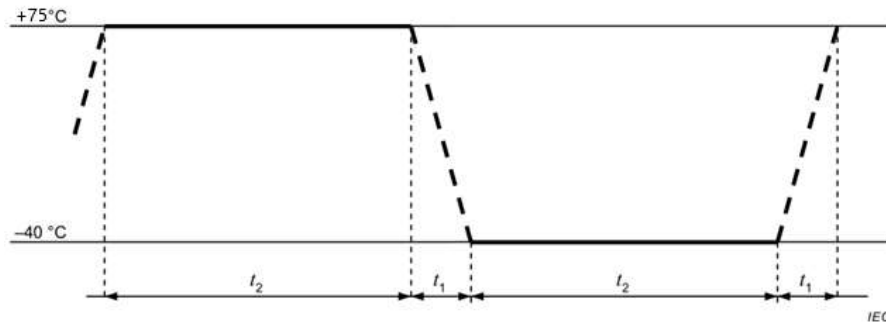

Figure 7.7.8 (5) Procedures of thermal shock

The test results shall comply with the requirements of 6.6.5.

(6) Thermal abuse

A test battery shall be placed in an oven where the temperature raised at a rate of 5 °C/min to 130 °C, at which the battery shall be held for 10 min. The test results shall comply with the requirements of 6.6.6.

7.7.9 Safety

(1) Safety device of cells

The case of cells is sealed with air sealing strips. Then the internal pressure of the case is raised to a value corresponding to 96°C, and the condition of the case is observed; then the internal pressure of the case is raised to a value corresponding to 149° C, and the condition of the case is observed. The case of cells shall comply with the requirements of 6.7.1.

(2) Heating of cells

The cells shall be placed in the test chamber where the temperature raises at a rate of 5°C/min to 90 °C, at which the cell shall be held for 2 hours, and the condition of cells is observed; then the temperature continues to raise at the same rate to 149°C and remain for 2 hours, and the condition is observed again. The cells shall comply with the requirements of 6.7.2.

(3) Short circuit of cells

After the temperature of the cell case is stable at 55°C, the cells are externally short-circuited. The total resistance of the external circuit shall be less than 0.1 ohm. The short circuit continues until the temperature of the cell case drops to 55°C. Then the short circuit goes on for another 1 hour at least.

The samples are observed for 6 hours.

The cells which are subjected to shock tests are used in this test.

The test results shall comply with the requirements of 6.7.3.

(4) Forced discharge of cells/batteries

The cell/battery shall be forcefully discharged at an initial current equal to the maximum continuous discharge current specified by the manufacturer at ambient temperature by connecting it in series with a 12V direct current power supply. The specified discharge current is obtained by connecting a resistive load of appropriate size and rating in series with the test cell and the direct current power supply. The discharge duration t_d of each cell/battery is equal to $t_d=C_r/I_i$

where:

T_d - Discharge duration

C_r - Rated capacity of the battery

I_i - Initial discharge current

This test shall be conducted with fully discharged test cells. After the forced discharge is completed, the test sample shall be observed for a further 7 days.

The test results shall meet the requirements of 6.7.4 (cells) and 6.7.7 (batteries).

(5) External short-circuit The test cell or battery, with its external case temperature kept at 55 °C shall be subjected to a short-circuit condition with a total external resistance of less than 0.1 Ω. This short-circuit condition is continued for at least 1h after the cell or battery external case temperature has returned to 55 °C. The test sample shall be observed for a further 6 h. The test shall be conducted using the test samples previously subjected to the shock test. The test results shall comply with the requirements of 6.7.5.

(6) Overdischarge

Each test battery shall be pre-discharged to 50 % depth of discharge. It shall then be connected in series with three undischarged batteries of the same type. A resistive load R_1 is connected in series with the assembly of batteries in Figure 7.7.9 (6) where R_1 is taken from Table 7.7.9 (6).

Table 7.7.9 (6) Overdischarged load resistance

Battery type	Load resistance R_1 Ω
CR17345	8.20
CR15H270	8.20

Note: Table will be modified or expanded when additional batteries of a

spiral

construction are standardized.

Example: When CR17345 and CR15H270 batteries were standardized, R₁ was determined from the end voltage of the assembly in Figure 7.7.9 (6), using the formula:

$$R = 4 \times 2.0V / 1A$$

Where:

2.0V - the end voltage taken from the specification tables in IEC 60086-2; 1A-the test current.

R₁ was then found by rounding R to the nearest value in Table 4 of IEC 60086-1:2015.

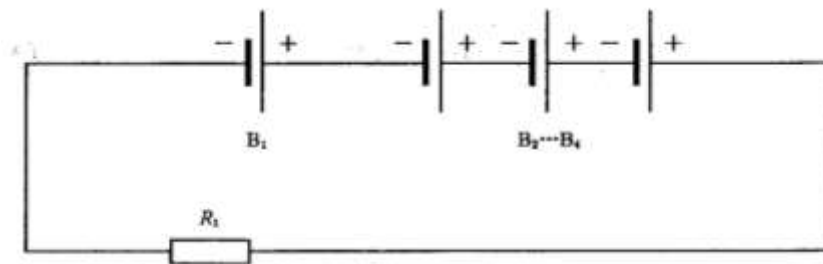

Figure 7.7.9 (6) Circuit diagram for overdischarge

B₁ - Test battery, subjected to two test for 50 % pre-discharge and, 75 % pre-discharge respectively;

B₂ ... B₄ –Additional batteries, undischarged;

R₁ - Resistive load

The test shall be continued for 24 h or until the battery case temperature has returned to ambient. The test shall be repeated with 75 % pre-discharged test batteries. The test results shall comply with the provision of 6.7.9.

(7) Crush

Pressure is applied by a vise or a hydraulic cylinder with a cylindrical piston so that the tested cell or component cell is compressed between two flat surfaces. The crushing is to be gradual with a speed of approximately 1,5 cm / s at the first point of contact. The crushing is to be continued until one of the three conditions below is reached; As soon as one of the below conditions has been obtained, the pressure shall be released

- ① The applied force reaches 13 kN ± 0.78 Kn; or

Example: The force can be applied by a hydraulic ram with a 32 mm diameter piston until a pressure of 17 MPa is reached on the hydraulic ram. (approx. 13 kN).

批注 [M9]: 译文与原文不一致

② The voltage of the cell drops by at least 100 mV; or ③ The cell is deformed by 50 % or more of its original thickness..

For cylindrical cells, the crush force shall be applied perpendicular to the longitudinal axis. For rectangular cells, the crushed force shall be applied to one of two axial directions perpendicular to the long axis of cells. The other axis is crushed next time; A coin cell shall be crushed by applying the force on its flat surfaces.. Each test cell or component cell is to be subjected to one crush only. The test shall be conducted using test cells or component cells that have not previously been subjected to other tests..

The test sample shall be observed for a further 6 h. The test results shall comply with the requirements of 6.7.6.

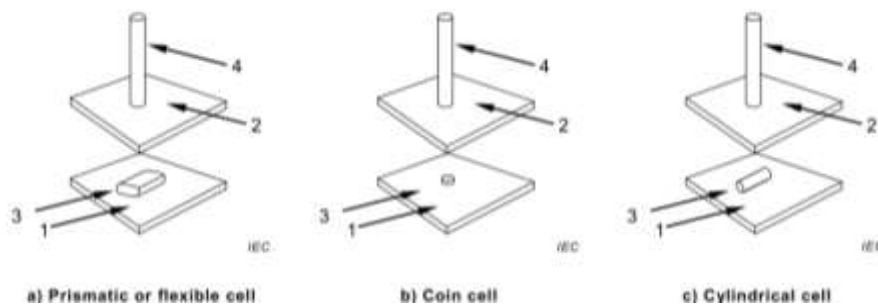

Figure 7.7.9 (7) Compression diagram

1-Test surface 2-Test surface 3-Tested cell 4-Compression piston

(8) Impact of heavy objects

The impact test is applicable to cylindrical cells greater than 20 mm in diameter.

The tested cells or component cells are placed on a flat plate surface. A stainless steel bar with a diameter of 15.8 mm (with the length of 60 mm or length of the tested cells, whichever is greater) is placed across the

centre of the test sample. A mass of $9.1 \text{ kg} \pm 0.1 \text{ kg}$ is dropped onto the stainless steel bar from a height of $61 \text{ cm} \pm 2.5 \text{ cm}$.

When the cylindrical or rectangular cells are subjected to the impact by heavy objects, the longitudinal axis shall be parallel to the plate and perpendicular to the longitudinal axis of the stainless steel bar placed in the center of the samples. The rectangular cells shall also be rotated 90° surrounding its longitudinal axis to ensure that its wide and narrow sides are subjected to the impact by heavy objects. When coin cells are subjected to impact by heavy objects, the flat surface shall be parallel to the plate with the stainless steel bar placed in the center of the cells.

Each test cell or component cell shall be subjected to one impact only.

The test shall be conducted using test cells or component cells that have not been previously subjected to other tests. The test sample shall be

observed for a further 6 h. The test results shall comply with the requirements of 6.7.6.

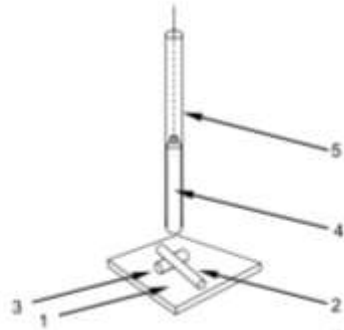

Figure 7.7.9 (8) Diagram of impact by heavy objects

1-Test surface 2- Stainless steel bar 3-Tested cells 4-Heavy objects 5-Declining channel of heavy objects

(9) Abnormal charging

Each test battery shall be subjected to a charging current three times the abnormal charging current I_c specified by the battery manufacturer by connecting it in opposition to a d.c. power supply. Unless the power supply allows for setting the current, the specified charging current shall be obtained by connecting a resistor of the appropriate size and rating in series with the battery. The test duration shall be calculated from the formula:

$$t_d = 2.5 \times C_n / (3 \times I_c)$$

where:

t_d - the test duration. In order to expedite the test, it is permitted to adjust the test parameters such that t_d does not exceed 7 days;

C_n - the nominal capacity;

I_c - the abnormal charging current declared by the manufacturer for this test.

The test results shall comply with the requirements of 6.7.8.

(10) Incorrect installation of the battery

A test battery is connected in series with three undischarged additional single cell batteries of the same type in such a way that the terminals of the test battery are connected in reverse. (see Figure 7.7.9 (10)). The resistance of the circuit shall be no greater than 0.1Ω . The circuit shall be powered for 24h or until the battery case temperature has returned to ambient.

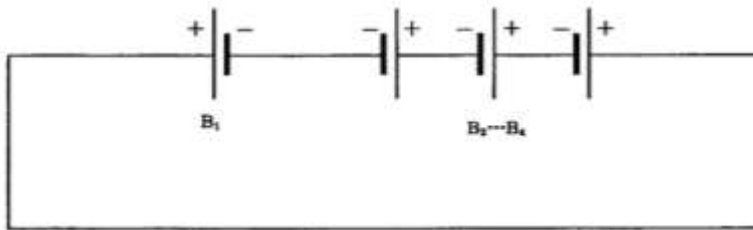

Figure 7.7.9 (10) Circuit of incorrect installation

B₁- Test cell;

B₂ ... B₄ - Additional cells, undischarged
The test results shall comply with the requirements of 6.7.10.

(11) Insulation, impregnation, filling and sealing materials

The materials are placed in a container measuring 150mm×80mm ×20mm with the materials not further than 13 mm from the container mouth while the materials are solidified according to the manufacturer's standard process. The temperature of the materials in the container shall be raised to 93°C±3°C and then the container is inverted for 24 hours to observe the fluidity of the materials. The materials shall be allowed to keep at -40°C±3°C for at least 8 hours to observe their contractility.

Test results of the materials shall comply with the requirements of 5.2.3.

(12) Leakage of cells

The tested cells shall have no sheathing or encapsulating materials.

Each cell shall be weighed before or after the electrolyte is filled in while records are made. Then the cells are stored at the ambient temperature of 55°C±3°C for 7 days. After the end of storage period of 7 days, cells are taken out for visual inspection of leakage. And then they are put into a dryer to cool down at room temperature for at least 2 hours. Each cell is accurately reweighed with the weight accurate to 0.1 mg while records are made. If leakage is found during the storage period of 7 days, then cell is deemed to fail to pass the test; if no leakage is found, all the cells shall be placed in the test chamber and stored for 21 days at the ambient temperature of 55°C±3°C. After the storage period of 21 days, all the cells shall be taken out and then put into a dryer to cool down for at room temperature for at least 2 hours. Each cell is accurately reweighed with the weight accurate to 0.1 mg while records are made. Mass loss of electrolyte is calculated between the storage period of 7 days and 28 days and the results shall comply with the requirements of 6.3.2.

(13) Moisture content of cells

The moisture content of cells shall be controlled by the manufacturer during the production with a report provided by manufacturer, and confirmed by

the ordering party. The moisture content of cells shall comply with the requirements of 5.10.

(14) Storage life

The storage life of batteries shall be tested as follows:

- ① The batteries are stored at the ambient temperature of $55^{\circ}\text{C}\pm 3^{\circ}\text{C}$ for 30 days (equivalent to stored 1 year at room temperature). During the storage period, the ambient temperature shall be continuously recorded to confirm the accuracy of the storage temperature. 50% of the batteries shall be stored in opposite polar positions (relative to the other 50% of the batteries). After the storage period, the batteries are checked for expansion, deflation, leakage, rupture or combustion. Then according to the requirements of 7.7.7.2.2, the discharge capacity at room temperature shall be tested, and the batteries shall comply with the requirements of 5.11a).
- ② After the batteries are stored for 60 months under the environmental conditions specified in 7.2, the discharge test shall be conducted with the method prescribed by the manufacturer, and the test results shall comply with the requirements of 5.11b).

7.8 Type approval

In order to apply for the type approval of CCS, items of type test specified in 7.5 can be consulted.

After the batteries are subjected to the machine matching test, they can be used as GMDSS batteries. During the machine matching test, the discharge test shall be carried out according to the standard conditions of the equipment, so as to determine the battery capacity (or load matching is conducted according to the data provided by the equipment manufacturers, so as to complete the capacity estimation). For equipment that requires to work under low temperature (abnormal room temperature conditions), the influence of low temperature on the battery capacity must be considered. It shall be verified by the low temperature capacity test whether the capacity of equipped batteries meets the power supply requirements of the equipment.

7.9 Single batch test (factory inspection)

7.9.1 If it is necessary to apply for the certificate of marine products issued by CCS upon approval of the single batch products, it is recommended to take the sampling method specified in 7.9.2; the inspection items can be carried out according to Table 7.9.2.

7.9.2 Sample size: Sampling shall be made according to 1% of each kind of products applying for the certificate, 5 products at least and 20 products at most.

Table 7.9.2 Test items of each single product/ each single batch of products

E-22 (201712) PRIMARY LITHIUM BATTERY

Test item	No. of required article	No. of test method
Appearance, marking and nameplates	5.4, 5.8	7.7.1
Color	5.6.1	7.7.3
Terminals form	5.7	7.7.4
Open circuit voltage of batteries	6.4.1.1	7.7.6.1.1
Load voltage of batteries	6.4.2.1	7.7.6.2.1
Insulation resistance	5.9.1	7.7.5
Dimension and weight	5.5	7.7.2