

Guideline No.: X-03(201610)



X-03

EMERGENCY TOWING

ARRANGEMENTS

Issued date: October 28, 2016

© China Classification Society

Foreword

CCS Product Inspection and Testing Guideline (hereinafter referred to as this Guideline) contains the technical requirements, inspection and testing criteria related to classification and statutory survey of marine products to be applied for CCS approval/inspection.

This Guideline frees the users to adopt other test methods and requirements which are equivalent to or are stricter than this Guideline.

This Guideline is published and updated by CCS, and is released at <http://www.ccs.org.cn>. Your comments or suggestions are welcomed and may be sent to our email addressed mp@ccs.org.cn.

Historical versions and release date : X-03(201610)

October 20, 2015

Main changes:

The “5 material and components” is amended to coordinate with the rules.

Contents

1 Application 4

2 Normative references 4

3 Terms and definitions 4

4 Drawings and documentation to be submitted 4

5 Materials and components..... 5

6 Design and technical requirements 5

7 Type test 5

8 Unit/batch inspection 10

EMERGENCY TOWING ARRANGEMENTS

1 Application

1.1 This Guideline is applicable to the emergency towing arrangements that are equipped according to the rules on tankers of 20000 tons deadweight and above, including oil tanks, liquid chemical cargo carriers and liquefied gas carriers.

1.2 Emergency towing arrangements equipped in accordance with Regulation 3-4, Chapter II-1 of SOLAS and MSC.1/Circ.1255 Guidelines for Owners/Operators on Preparing Emergency Towing Procedures, together with emergency towing procedure manual prepared in accordance therewith, are to be approved by the plan approval department onboard.

2 Normative references

Resolution Adoption of Guidelines on Emergency Towing Arrangements on tankers

Section 5, Chapter 3, PART TWO of CCS Rules for Classification of Sea-going Steel Ships

Regulation 3-4, Chapter II-1 of SOLAS

MSC.1/Circ.1255 Guidelines for Owners/Operators on Preparing Emergency Towing Procedures

MEG3-2008 Mooring Equipment Guidelines

OCIMF-MEG3-2008 Requirements of Some of the World's Main Oil Organizations for Single Point Mooring Equipment on Ships and VIQ

3 Terms and definitions

3.1 The relevant definitions in CCS Rules for Classification of Sea-going Steel Ships are applicable for the purpose of this Guideline.

4 Drawings and documentation to be submitted

4.1 When the approval is being applied for, the following drawings and documentation to be submitted are to be submitted to CCS for approval:

The following drawings and documentation to be submitted are to be submitted to CCS in duplicate by the manufacturer along with the application for approval:

- (1) Design calculations (fore part);
- (2) Design calculations (aft part);
- (3) Instructions for use;

- (4) General arrangement plan;
- (5) Fore part arrangement plan;
- (6) Aft part arrangement plan;
- (7) Chafing chain, chain stopper, fairlead, stopper plate, towing line, shackle, retrieving line;
- (8) Bracket, valve block, main axis, base, pneumatic winch, retrieving arrangements;
- (9) Storage box, force-bearing post, socket;
- (10) Test program for approval;
- (11) General information of the manufacturer: a. manufacturer history and current situation; b. production history and capacity for relevant products; c. information on production and testing equipment (including name, intended service, specifications, capacity, etc.); d. quality information (product quality statistics, quality inspection records of the user, etc.);
- (12) Quality control documents, warranty certificates, asbestos-free declaration.

The drawings and documentation to be submitted listed above will be reviewed by CCS in accordance with CCS rules, regulations and relevant requirements. Upon satisfactory review, a set of technical documents and approval test program sealed with CCS approval stamp or review stamp will be returned to the manufacturer.

5 Materials and components

5.1 Materials and components are to comply with relevant requirements of CCS Rules.

6 Design and technical requirements

The Design and technical requirements for the product are to be in compliance with Section 5, Chapter 3, PART TWO of CCS Rules for Classification of Sea-going Steel Ships and welding is to comply with the requirements of Chapter 3, PART THREE of CCS Rules for Materials and Welding.

7 Type test

Test contents

Test method (I)

- (1) Fore part emergency towing arrangements:
 - ① A test load equal to 2 times safe working load, 2000Kn (for ships of 20000-50000 tons deadweight or 4000Kn (for ships of ≥ 50000 tons deadweight), is to be applied to the

anchor cable along two directions at 90° angle to the left side and left side of the fairlead respectively and at 30° angle vertically downward at the same time, and the test load is to be maintained for 5 minutes.

- ② Various parts are to be examined and free from permanent destructive deformation after the test.

As shown in the diagrams below Figure 7(1):

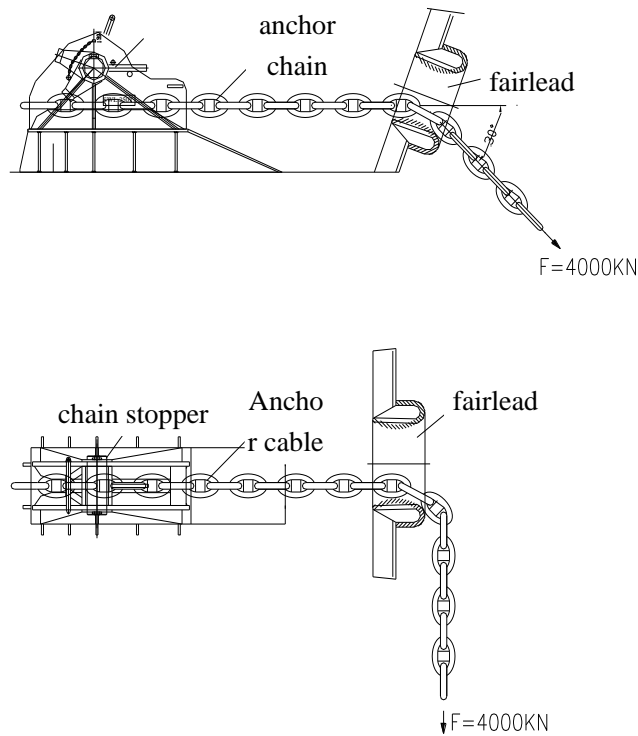

Figure 7(1) Schematic of Fore part emergency towing arrangements

(2) Aft part emergency towing arrangements:

- ① A test load equal to 2 times safe working load, 2000Kn (for ships of 20000-50000 tons deadweight) or 4000Kn (for ships of ≥ 50000 tons deadweight), is to be applied to the wire rope along the direction at 90° angle to the left-right direction of the fairlead and along the two directions at 30° angle vertically downward, and the test load is to be maintained 5 five minutes.
- ② Various parts are to be examined and free from permanent destructive deformation after the test.

As shown in the diagrams below Figure 7(2):

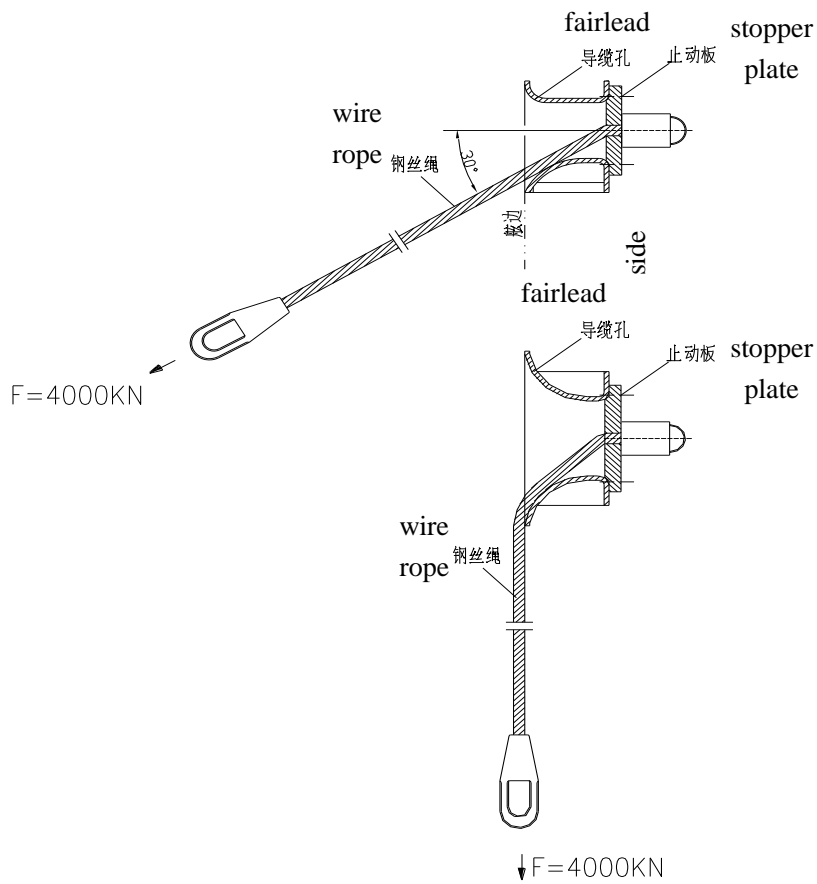

Figure 7(2) Schematic of Aft part emergency towing arrangements

Test method (II)

(1) Fore part emergency towing arrangements:

① Test of chain stopper

(a) The chain stopper is to be fixed onto the test bench. A test load equal to 2 times safe working load (2000Kn or 4000Kn) is to be applied to the chain stopper and maintained for 5 minutes.

(b) Various parts are to be examined and free from permanent destructive deformation after the test.

As shown in the diagram below Figure 7(3):

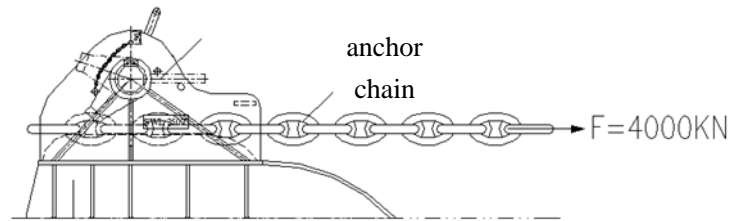

Figure 7(3) Schematic of chain stopper test

② Test of fairlead and anchor cable

- (a) The anchor cable is to be fed through the fairlead and a test load equal to 2 times safe working load (2000Kn or 4000Kn) is to be applied to the anchor cable along two directions, namely, at 90° angle to the left side of the fairlead and at 30° angle vertically downward at the same time, and at 90° angle to the right side of the fairlead and at 30° angle vertically downward at the same time, and the test load is to be maintained for 5 minutes.
- (b) Various parts are to be examined and free from permanent destructive deformation after the test.

As shown in the diagram below Figure 7(4):

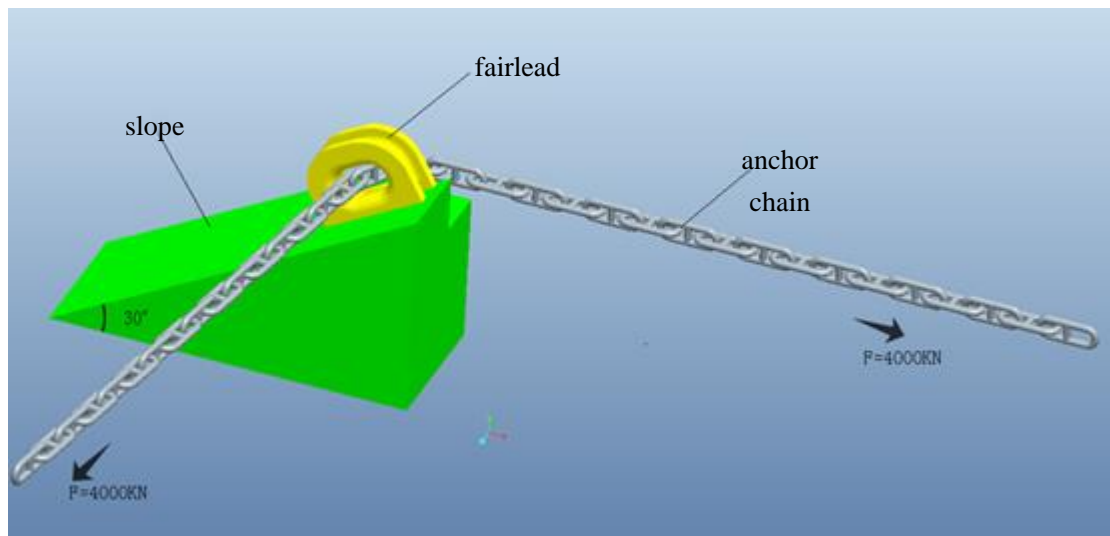

Figure 7(4) Schematic of fairlead and anchor chain test

(2) Aft part emergency towing arrangements:

① Test of stopper plate and wire rope thimble

- (a) The wire rope is to be fed through the fairlead and the wire rope thimble is to be in close contact with the stopper plate. Then a test load equal to 2 times safe working load (2000Kn or 4000Kn) is to be applied to the wire rope along two directions, namely, at

90 ° angle to the left side of the fairlead and at 30 ° angle vertically downward at the same time, and at 90 ° angle to the right side of the fairlead and at 30 ° angle vertically downward at the same time, and the test load is to be maintained for 5 minutes.

- (b) Various parts are to be examined and free from permanent destructive deformation after the test.

As shown in the diagram below Figure 7(5):

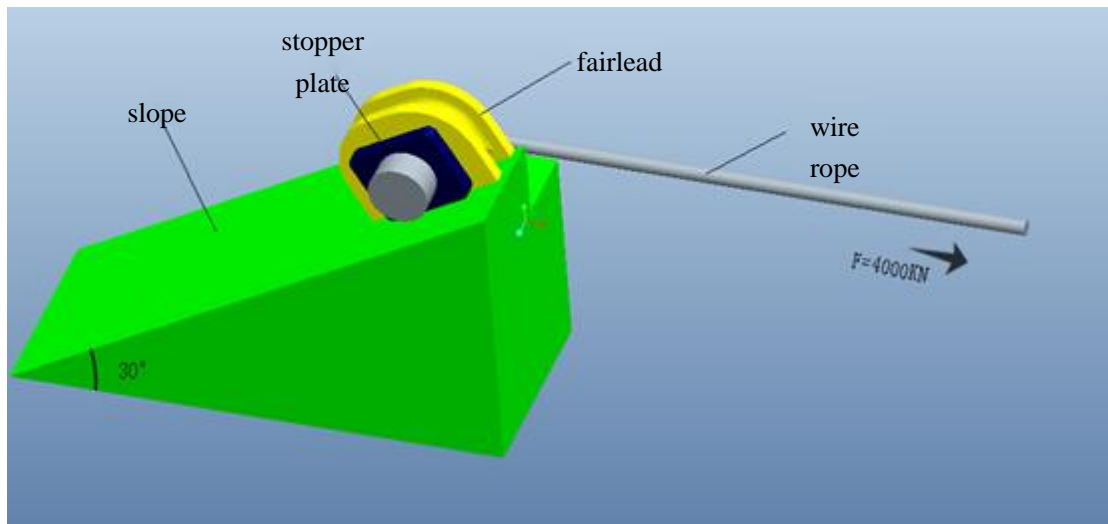

Figure 7(5) Schematic of stopper plate and wire rope clip test

② Test of wire rope and fairlead

- (a) The wire rope is to be fed through the fairlead and a test load equal to 2 times safe working load (2000Kn or 4000Kn) is to be applied to the wire rope along two directions, namely, at 90 ° angle to the left side of the fairlead and at 30 ° angle vertically downward at the same time, and at 90 ° angle to the right side of the fairlead and at 30 ° angle vertically downward at the same time, and the test load is to be maintained for 5 minutes.
- (b) Various parts are to be examined and free from permanent destructive deformation after the test.
- (c) Where it is not possible to test the entire piece of wire rope at one time, the wire rope may be tested section by section following step 1.

As shown in the diagram below Figure 7(6):

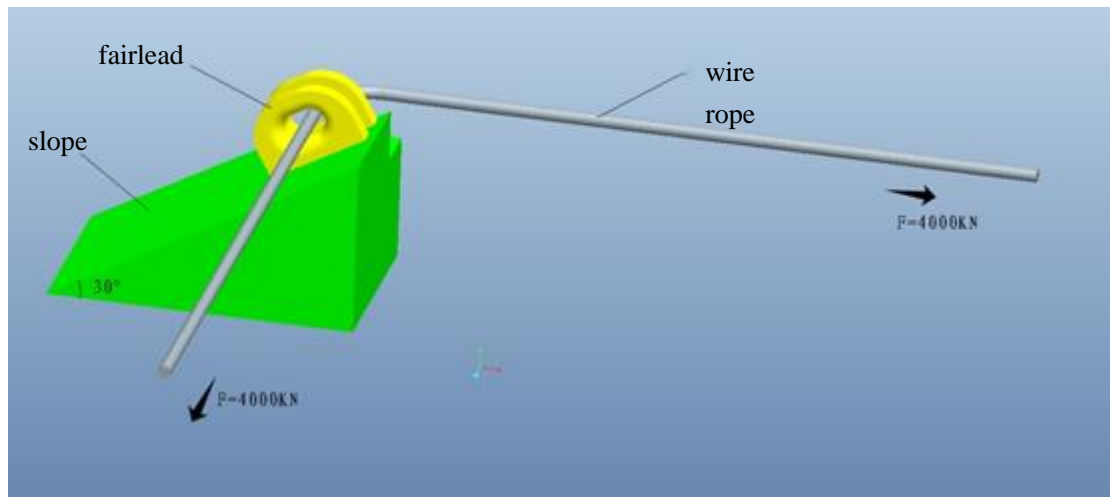

Figure 7(6) Schematic of wire rope and fairlead test

8 Unit/batch inspection

Unit/batch inspection of emergency towing arrangements may be carried out upon CCS type approval.

The specific inspection and test items may be determined through consultation with the local inspection organization of CCS after product approval.