

GUIDANCE NOTES

GD22-2015



**China Classification Society**

# **Guidelines for Type Approval Test of Electric and Electronic Products**

**2015**

CCS No.273 circular (IACS UR E10 Rev.5) , valid for 2008.1.1  
IACS UR E10 Rev.6, valid for 2016.1.1

Beijing  
November 2015

# Contents

## Chapter 1 General

1.1	Application.....	1
1.2	Definitions.....	1
1.3	Type approval test.....	4

## Chapter 2 Basic tests

2.1	Visual inspection.....	8
2.2	Performance test.....	8
2.3	Insulation resistance test .....	8
2.4	Power supply variation test.....	10
2.5	Power supply failure test.....	11
2.6	Inclination and rolling test.....	11
2.7	Vibration test.....	12
2.8	Dry heat test.....	14
2.9	Low temperature Test.....	14
2.10	Damp heat test (cyclic) .....	15
2.11	Damp heat test (steady state).....	17
2.12	Salt mist test Kb.....	18
2.13	Salt mist test Ka.....	19
2.14	High voltage test.....	20
2.15	Enclosure test.....	21
2.16	Flame retardant test.....	21

## Chapter 3 Electromagnetic compatibility test

3.1	General requirement.....	23
3.2	Measurement of conducted emissions.....	24
3.3	Measurement of radiated emissions from enclosure port.....	26
3.4	Electrostatic discharge immunity test.....	28
3.5	Test of Immunity to radiated, radiofrequency, electromagnetic field .....	30
3.6	Electrical fast transients/burst immunity test.....	33
3.7	Surge immunity test.....	35
3.8	Test of immunity to conducted low frequency interference.....	37
3.9	Test of immunity to conducted disturbances induced by radio-frequency fields.....	39

## Chapter 4 Maritime Navigation and Radiocommunication Equipment and Systems

4.1	General requirements.....	42
4.2	Type approval tests.....	42

Appendix A	International standards and China national standards referred to in the Guidelines.....	44
------------	---	----

# Chapter 1      General

## 1.1 Application

1.1.1 The Guidelines are applicable to the type approval tests for the following equipment used for ships and offshore installations:

- all equipment used for control, protection, safety, monitoring, alarm and internal communication (including electrical, electronic and programmable equipment);
- computer and its peripheral equipment;
- other low voltage electrical equipment and electronic equipment<sup>①</sup>;
- navigational equipment and radio communication equipment and system.

1.1.2 The type approval tests of computers according to the Guidelines are essentially type approval of hardware. Examination of software aspects is restricted to functional operation. Where necessary, approval of software may be carried out additionally.

1.1.3 The type approval tests for navigation and radio communication equipment and systems will be carried out in accordance with Chapter 4 of the Guidelines.

1.1.4 Equipment that are not specified in the Guidelines such as explosion-proof equipment, cables and lamps, etc. are to comply with the relevant requirements in CCS rules or other standards accepted by CCS.

## 1.2 Definitions

1.2.1 For the purpose of the Guidelines:

(1) Equipment under test (EUT)

An Equipment specimen for a type approval test, including all its auxiliary parts and systems such as refrigerators, heating installations and machinery vibration dampers which contribute to a complete function of the equipment.

(2) Performance test

An overall test to confirm full compliance of the equipment with all the performance requirements of the equipment standard (technical specifications).

(3) Performance check

A short test to confirm full compliance of the equipment with the essential performance requirements specified in the equipment standard (technical specifications).

(4) Functional test

A test to confirm full compliance of the equipment with the functional requirements of the equipment standard (technical specifications). In contrast to a complete performance test, a functional test is a simplified test sufficient to verify that the equipment under test (EUT) has not

---

<sup>①</sup> Requirement for high voltage electrical equipment is specified in PART FOUR of CCS Rules and Regulations for the Construction and Classification of Sea-going Steel Ships.

suffered any deterioration caused by the individual environmental tests.

(5) Non heat-dissipating equipment

An EUT, the hottest point on the surface of which, measured in free air conditions and in an atmosphere pressure (86 kPa to 106 kPa) required by the standard atmosphere condition for test, is less than 5 K above the ambient temperature after temperature stability has been reached.

(6) Heat-dissipating equipment

An EUT, the hottest point on the surface of which, measured in free air conditions and in an atmosphere pressure (86 kPa ~ 106 kPa) required by the standard atmosphere condition for test, is more than 5 K above the ambient temperature after temperature stability has been reached.

(7) Degradation of performance

An undesired departure in the operational performance of any device, equipment or system from its intended performance.

(8) Performance criterion A

The EUT is to continue to operate as intended during and after the test. No degradation of performance or loss of function is allowed as defined in the relevant equipment standard and in the technical specifications published by the manufacturer.

(9) Performance criterion B

The EUT is to continue to operate as intended after the test. No degradation of performance or loss of function is allowed as defined in the relevant equipment standard and in the technical specification published by the manufacturer. During the test, degradation or loss of function or performance which is self-recoverable is however allowed but no change of actual operating state or stored data is allowed.

(10) Performance criterion C

Temporary degradation or loss of function or performance is allowed during and after the test, provided the function is self-recoverable, or can be restored by the operation of the controls as defined in the relevant equipment standard and in the technical specification published by the manufacturer.

(11) Ripple voltage

The amplitude of the ripple voltage is represented in Figure 1.2.1 by the difference  $U_{\max} - U_{\min}$ .

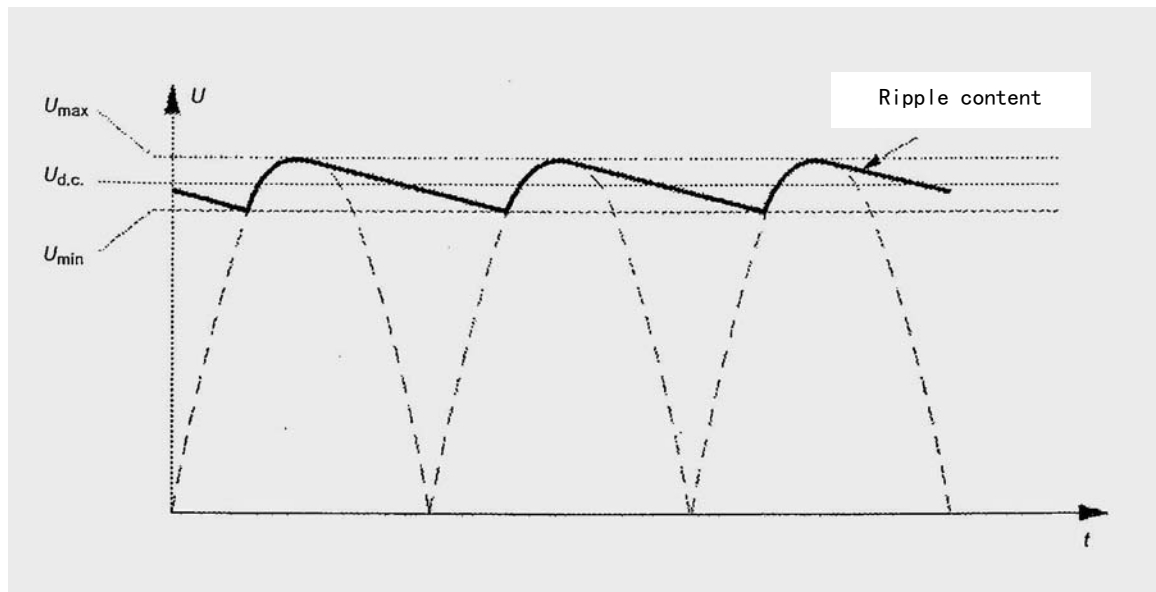

Figure 1.2.1 Example of ripple voltage waveforms (single-phase rectifier)

(12) Electromagnetic disturbance

Any electromagnetic phenomenon which may degrade the performance of a device, equipment or system, or adversely affect living or inert matter.

(13) Electromagnetic interference <sup>①</sup>

Degradation of the performance of an equipment, transmission channel or system caused by an electromagnetic disturbance.

(14) Electromagnetic compatibility

The ability of an equipment or system to function satisfactorily in its electromagnetic environment without introducing intolerable electromagnetic disturbances to anything in that environment.

(15) (Electromagnetic) emission

The phenomenon by which electromagnetic energy emanates from a source.

(16) (Electromagnetic) radiation

The phenomenon by which energy emanates from a source to a space in the form of electromagnetic wave or transmits in a space in the form of electromagnetic wave.

(17) Immunity (to a disturbance)

the ability of a device, equipment or system to perform without degradation in the presence of an electromagnetic disturbance.

(18) Port

Particular interface of an equipment with the external electromagnetic environment through which disturbances may be suscepled or emitted.

<sup>①</sup> Disturbance and interference mean the cause and the result respectively.

(19) Ground (earth)

Ship's whole metallic structure or a metallic ground plane specially placed.

(20) Reference ground (GRP)

Conductor whose potential is that to which the potential of other conductors refer.

### 1.3 Type approval tests

1.3.1 The purpose of a type approval test is to demonstrate that under the specified test conditions the equipment is able to operate as intended.

1.3.2 Environmental categories based on the site of equipment are given in Table 1.3.2.

Environmental categories

Table 1.3.2

Category	Description	Ambient Temperature Range
A	Controlled environments <sup>①</sup>	To manufacturer's specification
B	Enclosed spaces subject to temperature, high humidity and vibration	+5°C ~ +55°C
C	Enclosed spaces subject to generated heat from high humidity, vibration and other equipment	+5°C ~ +70°C
D	high vibration environment (e.g. mounted on reciprocating machinery)	+5°C ~ +55°C
E	Open decks	-25°C ~ +70°C

Note: <sup>①</sup> The spaces where the use of air-conditioners is agreed by CCS.

Equipment placed in a cold space other than environmental category E, of a temperature less than +5°C, is to be tested in its actual temperature.

1.3.3 Electrical and electronic equipment are to be type-tested according to their application and the sites they are installed as shown in Table 1.3.3a. Type approval tests for different types of equipment are shown in Table 1.3.3b.

Type approval tests for equipment in different environmental categories

Table 1.3.3a

Tests	Environmental categories				
	A	B	C	D	E
Visual inspection	X	X	X	X	X
Performance test	X	X	X	X	X
Insulation resistance test	X	X	X	X	X
Power supply variation test	X	X	X	X	X
Power supply failure test <sup>②</sup>	X	X	X	X	X
Inclination and rolling test <sup>③</sup>	X	X	X	X	X
Vibration test	X	X	X	X	X
Dry heat test	—	X	X	X	X
Low temperature Test	—	X	X	X	X
Damp heat test-cyclic	—	X	X	X	X
Damp heat test ( steady state)	X	—	—	—	—
Salt mist test Kb	—	—	—	—	X
Salt mist test Ka <sup>④</sup>	—	—	—	—	X
High voltage test	X	X	X	X	X
Enclosure test	X	X	X	X	X
Flame retardant test	Applicable to equipment with plastic parts				
Electromagnetic compatibility test	As specified in Chapter 3				
<p>Note: ① In the Table: “X” means to be tested; “—” means not to be tested. the same below.</p> <p>② Power supply failure test is only applied to the equipment for control, protection and safety, <b>monitoring and alarm</b> and computers.</p> <p>③ Equipment with no moving parts or free liquid surfaces do not need inclination and rolling test.</p> <p>④ Unless expressly provided in equipment standard, salt mist test Ka may be carried out on electrical machines and transformers on an open deck.</p>					

Type approval tests for different types of equipment

Table 1.3.3b

Equipment type Test	Electrical machines, transformers	Electrical apparatus and their outfits, instruments	All equipment used for control, protection, safety, monitoring and alarm and internal communication, computers and other electronic equipment
Visual inspection	X	X	X
Performance test	X	X	X
Insulation resistance test	X	X	X
Power supply variation test	X (Electric motor only)	X	X
Power supply failure test <sup>①</sup>	—	—	X
Inclination and rolling test <sup>②</sup>	X	X	X
Vibration test	X (micro motor only)	X	X
Dry heat test	—	—	X
Low temperature Test	—	—	X
Damp heat test-cyclic	X	X	X
Damp heat test( steady state) <sup>③</sup>	X	X	X
Salt mist test Kb	—	X <sup>④</sup>	X
Salt mist test Ka	X	—	—
High voltage test	X	X	X
Enclosure test	X	X	X
Flame retardant test	Applicable to equipment with plastic parts		
Electromagnetic compatibility test	As specified in Chapter 3		
<p>Note: ① Power supply failure test is only applied to the equipment for control, protection, safety, monitoring and alarm, and computers.</p> <p>② Equipment with no moving components or free liquid surfaces do not need inclination and rolling test.</p> <p>③ Applied to equipment placed in environment category A only.</p> <p>④ Unless expressly provided in equipment standard, salt mist test Kb is to be, in principle, carried out on these equipment placed on an open deck.</p>			

Some tests may be exempted subject to agreement of CCS; additional tests may be required by CCS, if considered necessary.

Test requirements of international standards or other equivalent standards on the equipment, if any, are to be adopted in the type approval tests.

1.3.4 A test program is to be made in accordance with the requirements in the Guidelines prior to type approval tests, and is subject to CCS approval.

1.3.5 Test sequence is to be confirmed by CCS prior to the test.

1.3.6 All tests, except for salt mist test, are to be, in principle, carried out on the same EUT, any exception is subject to CCS agreement.

1.3.7 The EUT may be re-calibrated between each test provided that the test result will not be affected.

1.3.8 For some tests, the relevant IEC standards (IEC publication) are applied, which have been stated in the Guidelines. The test procedure, equipment and configuration of these tests can be referred to in the latest version of these IEC standards. (Shown in Appendix A).

1.3.9 Other equivalent test methods may be adopted subject to agreement of CCS.

1.3.10 Type approval tests are to be carried out in a test institution approved or accepted by CCS.

## Chapter 2 Basic tests

### 2.1 Visual inspection

2.1.1 External structure, material, workmanship and designation of the EUT are inspected for conformity with:

- (1) related CCS Rules;
- (2) the manufacturer's specifications;
- (3) the equipment standard;
- (4) the design drawings and documents.

### 2.2 Performance test

#### 2.2.1 Test purpose

This test serves to verify that operation of EUT is in accordance with the specified requirements. **When the EUT is required to comply with an international performance standard, e.g. protection relays, verification of requirements in the standard are to be part of the performance testing required in this initial test and subsequent performance tests after environmental testing where required in these guidelines.**

#### 2.2.2 Standards applied

Relevant requirements in CCS rules and the equipment standard (technical specifications)

#### 2.2.3 Test conditions

- (1) The EUT is to operate at the rated operational voltage and frequency (AC equipment).
- (2) Places for testing are to be in the standard atmospheric conditions as follows:
  - ① Temperature: 15°C ~ 35°C;
  - ② Relative humidity: 30% ~ 90%;
  - ③ Atmospheric pressure: 86kPa ~ 106kPa.

#### 2.2.4 Method of test

An overall test is to be carried out on the performance of the EUT in accordance with the test method specified in the equipment standard (technical specifications) under the test conditions required in 2.2.3.

#### 2.2.5 Test result

The relevant performance requirement is to be fulfilled and deviation of the measured performance index within the limit of the equipment standard (technical specifications).

### 2.3 Insulation resistance test

#### 2.3.1 Test purpose

This test serves to verify that the insulation resistance of EUT remains within the specified tolerance limits. Insulation resistance test is to be carried out before and after: damp heat test, cold test and salt

mist test Kb and high voltage test.

### 2.3.2 Test conditions

Test voltage is to be in compliance with the following:

(1) For equipment used for control, protection, safety, **monitoring, alarm** and internal communication, computers and other electronic equipment, see Table 2.3.2(1).

Rated operational voltage $U_n$ (V)	Test voltage(DC) (V)
$\leq 65$	$2 \times U_n$ , min.24
$> 65$	500

(2) For other electrical equipment, see Table 2.3.2(2).

Rated voltage $U_n$ (V)	Test voltage(DC) (V)
$U_n \leq 250$	$2 \times U_n$ or 250
$250 < U_n \leq 1000$	500
$1000 < U_n \leq 1500$	1000

### 2.3.3 Method of test

(1) The test is to be performed between all **phases** and earth (enclosures) and where appropriate, **between the phases**.

(2) Certain parts e.g. filters and surge arrestors may be required to be disconnected before this test.

### 2.3.4 Test results

The insulation resistance values measured are not to be lower than those specified in Table 2.3.4.

Equipment		Min. insulation resistance value ( $M\Omega$ )	
		Before test	After test
Equipment used for control, protection, safety, <b>monitoring, alarm</b> and internal communication, computers and other electronic equipment <sup>①</sup>	$\leq 65$ V	10	1
	$> 65$ V	100	10
Other electrical equipment		In accordance with the equipment standard	
Note: ① For the equipment with complex multiloops, the minimum insulation resistance value may be lower depending on the specific situation.			

## 2.4 Power supply variation test

### 2.4.1 Test purpose

This test serves to verify that in the event of power supply variations EUT can operate normally.

### 2.4.2 Test conditions

Among the variations parameters listed below: for electrical components, the basis for the tests is the rated operational voltage and frequency (AC equipment), and for hydraulic/pneumatic components, the rated control pressure, in accordance with the equipment specification.

Electrical supply variations (A.C.) Table 2.4.2(1)

combination	Voltage variation permanent (%)	Frequency variation permanent (%)
1	+ 6	+5
2	+ 6	-5
3	-10	-5
4	-10	+ 5
	Voltage transient (%) 1.5s	Frequency transient (%) 5s
5	+ 20	+ 10
6	-20	-10

Electrical supply variations (D.C.) Table 2.4.2(2)

Voltage variation permanent ( %)	± 10
Voltage variation cyclic (%)	5
Voltage ripple (%) <sup>①②</sup>	10
Note: ① “Voltage ripple (%)”, means ratio of the amplitude of the ripple voltage to the rated operational voltage (DC) of EUT expressed in percentage, as $(U_{\max} - U_{\min}) / U_{d.c.}$ % shown in Figure 1.2.1.	
② Voltage ripple test is only applicable to DC equipment supplied by rectifier.	

Electric battery supply variations Table 2.4.2(3)

conditions	Voltage deviation (%)	
Electric battery supply for equipment connected to the battery during charging	+30	-25
Electric battery supply for equipment not connected to the battery during charging	+20	-25

Hydraulic/pneumatic power supply variations Table 2.4.2(4)

control pressure deviation	+20 %	-20 %
----------------------------	-------	-------

### 2.4.3 Method of test

(1) For equipment used for control, protection, safety, monitoring, alarm and internal communication, computers and other electronic equipment

The EUT is to operate for 15 min under each variation (or variation combination) as shown in Table 2.4.2(1) combinations 1 to 4, Table 2.4.2(2), Table 2.4.2(3) and Table 2.4.2(4). Additionally voltage transient test and frequency transient test are to be carried out 3 times each on the EUT as shown in Table 2.4.2(1) combinations 5 to 6.

(2) Other electrical equipment

The EUT is to operate for 15 min under each variation (or variation combination) as shown in Table 2.4.2(1) combinations 1 to 4, Table 2.4.2(2) and Table 2.4.2(3).

### 2.4.4 Test result

(1) For electrical machines and transformers: the EUT is to operate reliably during the test and operate normally after the test.

(2) For the he electrical and electronic equipment other than electrical machines and transformers: during and after the test, voltage transient as shown in Table 2.4.1(1) combinations 5 to 6 is to fulfill the Performance criterion B in Chapter 1, and all the other test results are to fulfill the Performance criterion A.

## 2.5 Power supply failure test

### 2.5.1 Test purpose

This test serves to examine the EUT's behavior upon loss and restoration of supply.

### 2.5.2 Test conditions

In the case of electrical and electronic components, the tests are performed at the rated operational voltage and frequency (AC equipment) and, in the case of hydraulic/pneumatic components, at the rated control pressure:

- 3 interruptions within a 5-minute period;
- 30s pause between switching off and switching back on.

**Note: The time of 5 minutes may be exceeded if the equipment under test needs a longer time for start up, e.g. booting sequence. For equipment which requires booting, one additional power supply interruption during booting to be performed.**

### 2.5.3 Test result

During and after test, the results of verification of equipment behavior are to fulfill the requirements of Performance criterion C as specified in Chapter 1.

## 2.6 Inclination and rolling test

### 2.6.1 Test purpose

This test serves to verify that the EUT operates normally under the influence of inclinations and rollings.

#### 2.6.2 Test conditions

- (1) During the test, the EUT is operated under the rated operational voltage and frequency (AC equipment).
- (2) The EUT inclines to the fore, aft, left and right directions at an angle of 22.5°. For equipment that can not incline to the four directions at 22.5°, for example: electrical generator, its real situations will be considered.
- (3) The EUT rolls along the fore-aft horizontal axis and left-right horizontal axis at an angle of 22.5° with a period of 10 seconds from one position to another. The period of testing is 15 min.
- (4) On ships for the carriage of liquefied gases and dangerous chemicals, the emergency power supply is to remain operational with the ship flooded up to a maximum final athwart ship inclination of 30°.

#### 2.6.3 Method of test

- (1) The EUT is installed in the testing equipment for inclinations and rollings in its normal operating position. The EUT is connected to power and operates.
- (2) The EUT is inclined along the fore, aft, left and right directions at an angle of 22.5°. The period of testing in each position should be sufficient to fully evaluate the behaviour of the EUT, but normally not less than 15 min.
- (3) The EUT rolls along the fore-aft horizontal axis and left-right horizontal axis at an angle of 22.5° with a period of 10 seconds from one position to another. The period of testing is not less than 15 min.

#### 2.6.4 Test result

During and after the test, the EUT is to operate normally with no abnormality or damage.

### **2.7 Vibration test**

#### 2.7.1 Test purpose

This test serves to verify that the EUT operates normally under the influence of vibrations.

#### 2.7.2 Standard applied.

IEC Publication 60068 -2 -6, Test Fc.

#### 2.7.3 Test conditions

- (1) During the test, the EUT is operated under the rated operational voltage and frequency (AC equipment).
- (2) Vibration test parameters are given in Table 2.7.3(2).

Vibration test parameters

Table 2.7.3(2)

Condition	Frequency (Hz)	Amplitude (mm)	Acceleration ( $m / s^2$ )
Normal vibration conditions	2 (+3/0) ~ 13.2	±1.0	—
	13.2 ~ 100	—	±6.9 (or 0.7g)
Severe vibration conditions (such as on diesel engines, air compressors and other similar conditions)	2 (+3/0) ~ 25	±1.6	—
	25 ~ 100	—	±39 (or 4.0g)
More severe vibration conditions for example on exhaust manifolds or fuel oil injection systems of diesel engines. For equipment specified for increased vibration levels the vibration test is to be conducted at the agreed vibration level, frequency range and duration	40 Hz~2000 Hz, acceleration $\pm 98 m / s^2$ (or 10.0g); temperature 600°C		

#### 2.7.4 Method of test

- (1) The EUT is to be fastened to the vibration table by its normal means of support and in its normal operating position and is connected to power.
- (2) A sweep test is to be carried out in search of resonance at a frequency sweep rate up to 1 oct / min and at a frequency range and amplitude specified in Table 2.7.3(2).
- (3) If no obvious resonance occurred, the endurance test is to be carried out at a frequency of 30Hz for 90 min.
- (4) A vibration endurance test is to be carried out for duration of 90 minutes at each resonance frequency at which  $Q \geq 2$  is recorded. where sweep test is to be carried out instead of the discrete frequency test and a number of resonant frequencies is detected close to each other, duration of the test is to be 120 min. Sweep over a restricted frequency range between 0.8 and 1.2 times the critical frequencies can be used where appropriate.

Note: Critical frequency is a frequency at which the equipment being tested may exhibit:

- malfunction and/or performance deterioration;
- mechanical resonances and/or other response effects occur, e.g. chatter.

- (5) Measures may be taken to avoid dangerous frequency or to reduce the Q value during the test, but resonance is to be researched and a vibration endurance test re-carried out.
- (6) The test is to be carried out in the three mutually perpendicular axes.
- (7) Further information is given in IEC 60068-2-6.

#### 2.7.5 Test result

No abnormality or damage is incurred to the EUT during the test, and the EUT is able to operate normally after the test.

## 2.8 Dry heat test

### 2.8.1 Test purpose

This test serves to verify that the EUT operates normally under the influence of dry heat.

### 2.8.2 Standard applied

For non heat-dissipating equipment: IEC Publication 60068-2-2, Test Bb.

For heat-dissipating equipment: IEC Publication 60068-2-2, Test Bd.

### 2.8.3 Test conditions

(1) During the test, the EUT is operated under the rated operational voltage and frequency (AC equipment). Any cooling systems provided in the heat-dissipating equipment may be put into use.

(2) Test temperature/duration:

55°C±2°C/16h; or

70°C ±2°C/16h (applied to equipment installed in C and E environmental categories);

For equipment specified for increased temperature the dry heat test is to be conducted at the agreed test temperature and duration.

### 2.8.4 Method of test

(1) The EUT is to be placed in the effective working space of a chamber at normal room temperature and is connected to power and operates. The temperature is then to be raised to and maintained at 55°C±2°C, for a period of 16 h; or

the EUT is to be placed in the effective working space of a chamber at normal room temperature and is connected to power and operates. The temperature is then to be raised to and maintained at 70°C ±2°C, for a period of 16 h.

(2) The EUT is subjected to a functional test during the last 1 h at the test temperature.

(3) The EUT is returned to normal environmental conditions and then subjected to a performance test.

(4) Further information is given in IEC 60068-2 -2.

### 2.8.5 Test result

The test result is to fulfill the relevant equipment standard (technical specifications).

## 2.9 Low temperature Test

### 2.9.1 Test purpose

This test serves to verify that the EUT operates normally under the influence of low temperature.

### 2.9.2 Standard applied

For non heat-dissipating equipment: IEC publication 60068-2-1, Test Ab.

For heat-dissipating equipment: IEC publication 60068-2-1, Test Ad.

### 2.9.3 Test conditions

(1) During the test the EUT is disconnected unless for a functional test;

(2) Test temperature: + 5°C±3°C; or

- 25°C±3°C; or

the actual temperature of the space where the EUT is placed<sup>①</sup>;

(3) Duration: 2h.

#### 2.9.4 Method of test

(1) Insulation resistance test is to be carried out on the EUT prior to the test according to the description in 2.3.

(2) The EUT is to be placed in the effective working space of a chamber at normal room temperature. The temperature is then to be reduced to, and maintained at one of the test temperatures listed in 2.9.3(2), for a period of 2h. Any heating devices provided in the EUT may be put into use.

(3) During the last 1h of the test a functional test (not needed on heat-dissipating equipment) is to be carried out at the test temperature. During the test the EUT is disconnected unless for a functional test.

(4) The EUT is subjected to a functional test during the last 1 h at the test temperature.

(5) The EUT is returned to normal environmental conditions and then subjected to an insulation resistance test and a performance test.

(6) Further information is given in IEC publication 60068-2-1.

#### 2.9.5 Test result

The test result is to fulfill the relevant equipment standard (technical specifications) and the insulation resistance values are to be in accordance with 2.3.4.

### 2.10 Damp heat test (cyclic)

#### 2.10.1 Test purpose

This test serves to verify that the EUT operates normally under the influence of damp heat.

#### 2.10.2 Standard applied

IEC 60068-2-30, Test Db.

#### 2.10.3 Test conditions

(1) Temperature: 55°C±2°C;

(2) Relative humidity: 90%~95%;

(3) Test duration: 2 cycles (24h per cyclic); or

6 cycles (24h per cyclic) (applicable to electrical machines and transformers only).

#### 2.10.4 Method of test

##### 2.10.4.1 Electrical and electronic equipment except for electrical machines and transformers

(1) Insulation resistance test is to be carried out on the EUT prior to the test according to the description in 2.3.

(2) The EUT is to be placed in the effective working space of a chamber. Pre-conditioning is to be

---

<sup>①</sup> Only applied to equipment placed in a cold space other than environmental category E, of a temperature less than +5°C.

carried out at temperature  $25^{\circ}\text{C} \pm 3^{\circ}\text{C}$  and relative humidity **at least 95%** to make the temperature at EUT reach stable.

(3) Two cycles are to be carried out as shown in Figure 2.10.4.1(3).

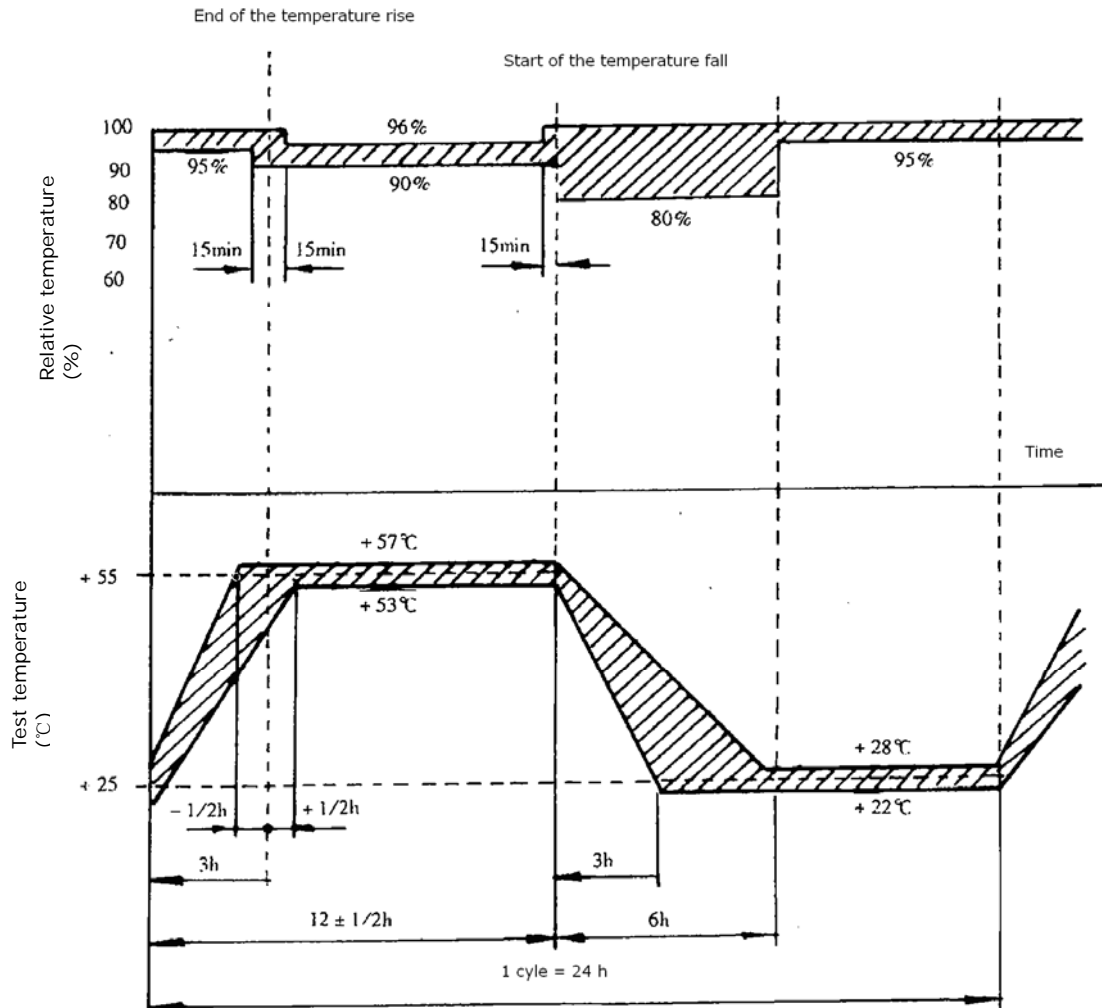

Figure 2.10.4.1(3) Test cycle

(4) The EUT is to be connected to power and kept in its operative condition during the first cycle and switched off during the second cycle except for a functional test. A functional test is to be carried out during the first 2 h of the first cycle at high temperature and high humidity. **Duration of the second cycle can be extended due to more convenient handling of the functional test.**

(5) The EUT is to be carried out from the chamber after the test cycle is completed and recovered at standard atmosphere conditions. Moisture on the surface of the EUT and its components may be removed by hand.

(6) After being recovered, the EUT is subjected to an insulation resistance test in accordance with 2.3 and a performance test.

(7) Further information is given in IEC publication 60068-2-30.

#### 2.10.4.2 Electrical machines and transformers

(1) Insulation resistance test is to be carried out on the EUT prior to the test according to the description in 2.3.

(2) The EUT is to be placed in the effective working space of a chamber. Pre-conditioning is to be carried out at temperature  $25^{\circ}\text{C}\pm 3^{\circ}\text{C}$  and relative humidity 45%~75% so that the temperature at EUT reaches stable.

(3) Relative humidity in the chamber is to be raised to  $\geq 95\%$  and six cycles are to be carried out as shown in Figure 2.10.4.1(3). During the period when the temperature is reduced, the low limit of humidity is 85%.

(4) Insulation resistance test of the EUT is to be carried out in the chamber after the 6th hour of the last cycle at low temperature and high humidity. Then a high voltage test between windings and housing is to be carried out and an insulation resistance test is to be immediately carried out after the high voltage test.

(5) A visual inspection is to be carried out during the 24 h and a surface paint adherence test carried out during the 8h to 24h after the EUT is taken from the chamber.

(6) Further information is given in IEC publication 60068-2-30.

#### 2.10.5 Test result

The test result is to fulfill the relevant equipment standard (technical specifications) and the insulation resistance values are to be in accordance with 2.3.4.

### 2.11 Damp heat test( steady state)

#### 2.11.1 Test purpose

This test serves to verify that the EUT operates normally under the influence of damp heat.

#### 2.11.2 Standard applied

IEC publication 60068-2-78, Test Cab: damp heat (steady state).

#### 2.11.3 Test conditions

- (1) Temperature:  $40^{\circ}\text{C}\pm 2^{\circ}\text{C}$ ;
- (2) Relative humidity: 90%~95%;
- (3) Duration: 96h.

#### 2.11.4 Method of test

(1) Insulation resistance test is to be carried out on the EUT prior to the test according to the description in 2.3.

(2) The EUT is to be placed in the effective working space of a chamber. Under the condition that

humidity is not raised, the temperature is to be raised from 20°C to 40°C±2°C during 2 h and pre-conditioning carried out. After the temperature at EUT reaches stable, the humidity is to be raised to 90%~95%.

(3) The EUT is to be kept for 96 h under the conditions of humidity 90%~95% and temperature 40°C ±2°C, following which temperature is to be reduced to 20°C within 1h to 2h. The EUT is then to be taken out and recovered under normal temperature.

(4) Functional tests are to be carried out during the first hour, at the 50th hour and the last 2 hours of the test.

(5) Insulation resistance test and performance test of the EUT are to be carried out after the test is completed and the EUT recovered.

(6) Further information is given in IEC 60068-2-78.

#### 2.11.5 Test result

The test result is to fulfill the relevant equipment standard (technical specifications) and the insulation resistance values are to be in accordance with 2.3.4.

## 2.12 Salt mist test Kb

### 2.12.1 Test purpose

This test serves to verify that no corrosion is caused and no functional affections occur to the EUT under the influence of salt mist.

### 2.12.2 Standard applied

IEC publication 60068-2-52, Test Kb.

### 2.12.3 Test conditions

(1) Test solution: mass concentration 5%±1% sodium chloride solution (above chemically pure) pH value 6.5 to 7.2 at 20 °C±2°C.

(2) Relative humidity: 90%~95%.

(3) Temperature: 40°C±2°C.

(4) Test period: 4 spraying periods. Each of duration 2 h for continuous spraying, with a damp heat storage period of 7 days after each.

### 2.12.4 Method of test

(1) Insulation resistance test and functional test carried out on the EUT prior to the test according to the description in 2.3.

(2) The EUT is to be placed in a salt mist chamber in its normal operating position and continuously sprayed for 2 h at 15 °C~35 °C. At the end of the spraying period, the EUT is to be placed in its normal operating position in a damp heat chamber which is maintained at a temperature of 40°C±2°C and a relative humidity of 90%~95% for a period of seven days.

(3) The EUT is not to operate during the test and a functional test is to be carried out on the 7th day of

each storage period.

(4) On completion of the test the EUT is to be exposed to normal atmosphere conditions and recovered for 4~6h, following which an insulation and a performance test is to be carried out. On completion of exposure, the equipment shall be examined to verify that deterioration or corrosion (if any) is superficial in nature.

(5) Further information is given in IEC publication 60068-2-52.

#### 2.12.5 Test result

(1) The measured insulation resistance values are to be in accordance with the description in 2.3.4.

(2) The test result is to fulfill the relevant equipment standard (technical specifications) and no obvious deterioration or corrosion on the metallic surface can be detected by inspection with naked eye.

### 2.13 Salt mist test Ka

#### 2.13.1 Test purpose

This test serves to verify that no corrosion is caused to the components of the EUT under the influence of salt mist.

#### 2.13.2 Standard applied

IEC publication 60068-2-11, Test Ka.

#### 2.13.3 Test conditions

(1) Test solution: mass concentration  $5\% \pm 1\%$  sodium chloride solution (above chemically pure), saline solution pH value 6.5~7.2 at  $35\text{ }^\circ\text{C} \pm 2\text{ }^\circ\text{C}$ .

(2) Temperature in chamber:  $35\text{ }^\circ\text{C} \pm 2\text{ }^\circ\text{C}$ .

(3) Duration: depending on base metals and coatings, as shown in Table 2.13.3.

Test duration

Table 2.13.3

Base metal	Coating	Duration h
Carbon steel	Zinc	48
Carbon steel	Chromium galvanized on the outermost	48
Copper and copper alloy	Nickel-chromium	96
Copper and copper alloy	Nickel	48
Copper and copper alloy	Silver, gold	24
Copper and copper alloy	Tin	48

#### 2.13.4 Method of test

(1) The test specimens are to be cleaned prior to the test.

(2) The specimens are to be placed in a salt mist chamber. If a specimen is of a flat plate nature, it is to be so positioned that the surface under test is inclined at an angle  $30^\circ$  to the vertical direction. The

specimens are not to be in contact with each other. Continuous spraying is to be carried out at the duration as shown in Table 2.13.3.

(3) On completion of the test, the specimens are to be gently washed in running water to remove salt sediment, and rinsed in distilled water. The temperature of the water used for washing is not to exceed 35°C. Then the specimens are to be exposed in normal atmosphere condition and recovered for 1h~2h.

#### 2.13.5 Test result

The test result is to fulfill the relevant equipment standard (technical specifications) and no obvious deterioration or corrosion is to be detected on the metallic surface detected by inspection with naked eye.

### 2.14 High voltage test

#### 2.14.1 Test purpose

This test serves to verify the insulation characteristics of separate circuits against each other and all circuits against enclosures.

#### 2.14.2 Test conditions

(1) Test voltage value:

- ① Test voltage of equipment used for control, protection, safety, **monitoring, alarm** and internal communication, computers and other electronic equipment is shown in Table 2.14.2 (1).

Test voltage (value) Table 2.14.2(1)

Rated operational voltage Un (V)	Test voltage (V)
$\leq 65$	$2 \times Un + 500$
66 ~ 250	1500
251 ~ 500	2000
501 ~ 690	2500

- ② Test voltage of electrical equipment is shown in Table 2.14.2 (2), except for electrical machines, which is in accordance with IEC publication 60034-1.

Test voltage (value) Table 2.14.2 (2)

Rated operational voltage Un (V)	Test voltage (V)
$\leq 60$	1000
61 ~ 300	2000
301 ~ 660	2500
661 ~ 800	3000
801 ~ 1000	3500
1001 ~ 1500 <sup>①</sup>	3500

Note: ① Applied to D.C. equipment only.

(2) Power frequency: 50 Hz; or  
60 Hz.

(3) Test duration: 1 min.

#### 2.14.3 Method of test

(1) Insulation resistance test is to be carried out on the EUT prior to the test according to the description in 2.3.

(2) Separate circuits of the EUT are to be tested against each other and all circuits connected with each other against earth (enclosures).

(3) EUT components of different voltage may be tested separately.

(4) Printed circuits with electronic components which could be subject to damage during test may be removed prior to the test.

#### 2.14.4 Test result

No breakdown or flashover is to be observed. Insulation resistance test is to be carried out immediately after the test with the result in accordance with 2.3.4.

### **2.15 Enclosure test**

#### 2.15.1 Test purpose

This test serves to verify that the enclosure of the EUT meets the “degrees of protection”.

#### 2.15.2 Standard applied

IEC publication 60529.

### **2.16 Flame retardant test**

#### 2.16.1 Test Purpose

This test serves to verify that plastic components of the EUT are flame retardant and self-extinguishing under the influence of a pre-defined flame.

#### 2.16.2 Standard applied

IEC Publication 60092-101 or IEC 60695-11-5.

#### 2.16.3 Test conditions and method of test

(1) The flame of the gas burner (conventional Bunsen burner), when adjusted in still air and in the vertical position, is approximately 125 mm long, the blue part of the flame being about 35 mm long.

(2) The test specimen is to be fastened to a thin metal wire so that its longitudinal axis is inclined at an angle approximately 45° to the horizontal and its transverse axis is horizontal.

(3) The test specimen consists of a bar or strip at least 120 mm long, 10 mm wide and 3 mm thick. Test specimens of other sizes may also be accepted. An increase in the length beyond 120 mm is acceptable.

In the case of tubes or sections, the straight section of which is not notably larger than a rectangle of 10 mm x 3 mm in size and area, the test may be carried out on a 120 mm length of the object.

(4)The test is to be carried out under standard atmospheric condition and away from draughts. The Bunsen burner axis is to be set vertically in such a position that the tip of the blue part of the flame just touches the lower end of the specimen. The flame is to be applied five times for 15 s at a time, with a interval of 15 s between each application. After the last application, the specimen is to be allowed to burn itself out.

(5) In addition to the above Bunsen test method, the test is performed with the EUT or housing of the EUT applying needle-flame test method.

#### 2.16.4 Test result

(1) Bunsen test method :the burnt out or damaged part of the specimen is not to be more than 60 mm long.

(2) needle-flame test method : no flame, no incandescence or in the event of a flame or incandescence being present, it shall extinguish itself within 30 s of the removal of the needle flame without full combustion of the test specimen.Any dripping material shall extinguish itself in such a way as not to ignite a wrapping tissue. The drip height is 200 mm ± 5 mm.

## Chapter 3 Electromagnetic compatibility test

### 3.1 General requirement

3.1.1 Electrical and electronic equipment is subject to emission measurements and immunity tests (all referred to as test(s) hereafter) as specified in 3.1.2 and is to reach a result as required so as to maintain its electromagnetic compatibility in its normal operation.

3.1.2 Different types of electrical and electronic equipment have different characteristics and are therefore subject to different electromagnetic compatibility tests. The tests needed for some types of equipment are shown in Table 3.1.2.

Electromagnetic compatibility tests for different types of electrical and electronic equipment Table 3.1.2

Test  Equipment		Emission measurements		Immunity tests					
		conducted emissions	radiated emissions from enclosure port	Electro-Static discharge	Radiated, radio-frequency, electromagnetic field	Electrical fast transients /burst	Surge	Conducted low frequency interference <sup>①</sup>	Conducted disturbances induced by radio-frequency fields
electrical machines and converters <sup>②</sup>	Induction motor/ generators	—	—	—	—	—	—	—	—
	Synchronous machines	X	—	—	—	—	—	—	—
	D.C. machines	X	—	—	—	—	—	—	—
	electronic automatic voltage regulators and their associated equipment	X	X	X	X	X	X	X	X
	cycloconverters	X	X	X	X	X	X	X	X
	Synchronous converters	X	X	X	X	X	X	X	X
	Pulse width converters	X	X	X	X	X	X	X	X
	D.C. converters transformers	X	X	X	X	X	X	X	X
Switchgear and control systems	Circuit breakers, contactors without electronic parts	—	—	—	—	—	—	X	—
	Relay operated control devices	—	—	—	—	—	X	—	—
	Electronic control devices	X	X	X	X	X	X	X	X
Intercommunication and signal processing equipment	Electronic alarm monitor	X	X	X	X	X	X	X	X
	Electronic control system	X	X	X	X	X	X	X	X
	Automation system	X	X	X	X	X	X	X	X
	Computers	X	X	X	X	X	X	X	X

	Sensors	X	X	X	X	X	X	X	X
Integrated systems	Integrated cargo monitoring system	X	X	X	X	X	X	X	X
	Integrated bridge system	X	X	X	X	X	X	X	X
Note: ① Not applicable to the equipment only supplied by electric battery. ② Converters for charging may need emission measurements only.									

### 3.2 Measurement of conducted emissions

#### 3.2.1 Test purpose

This test serves to measure any signals generated by equipment, which appear on its power supply port (AC and DC) and which can be conducted into the ship's power supply system and potentially disturb other equipment.

#### 3.2.2 Standards applied

CISPR publication 16-2-1.

#### 3.2.3 Test conditions

- (1) During the test, the EUT is operated at its rated operational voltage and frequency (AC equipment).
- (2) Conducted emission is to be measured on the EUT of frequency range 10 kHz ~ 30 MHz in.

#### 3.2.4 Method of test

- (1) The emission is to be measured by means of the quasi-peak measuring receivers specified in CISPR 16-2-1. An artificial mains V-network in accordance with CISPR 16-2-1 is to be used to provide a defined impedance at high frequencies across the terminals of the EUT, and to isolate the test circuit from unwanted radio frequency signals on the supply mains. The measuring bandwidth in the frequency range 10 kHz~150 kHz is to be 200 Hz, and in the frequency range 150 kHz~30 MHz is to be 9 kHz.
- (2) The power input cables between the A.C. and the D.C. power ports of the EUT and the artificial mains network is to be screened and not exceed 0.8 m in length. If the EUT consists of more than one unit with individual A.C. and/or D.C. power ports, power ports of identical nominal supply voltage may be connected in parallel to the artificial mains supply network.
- (3) Measurements are to be made with all measuring equipment and the EUT mounted, and bonded to, an earth plane. Where provision of an earth plane is not practicable, equivalent arrangements are to be made using the metallic frame or mass of the EUT as the earth reference.
- (4) Further information is given in CISPR 16-2-1.

#### 3.2.5 Test result

In the frequency range 10 kHz~30 MHz, the radio frequency voltage of the power supply terminals of the EUT is not to exceed the limits that are shown in Figure 3.2.5 and listed in Table 3.2.5, sorted by frequency ranges.

Site	Limits of conducted emissions	
	Frequency range	limits
Bridge and deck zone	10 kHz ~ 150 kHz	96 dB $\mu$ V ~ 50 dB $\mu$ V
	150 kHz ~ 350 kHz	60 dB $\mu$ V ~ 50 dB $\mu$ V
	350 kHz ~ 30 MHz	50 dB $\mu$ V
General power distribution zone	10 kHz ~ 150 kHz	120 dB $\mu$ V ~ 69dB $\mu$ V
	150 kHz ~ 500 kHz	79 dB $\mu$ V
	500 kHz ~ 30 MHz	73 dB $\mu$ V

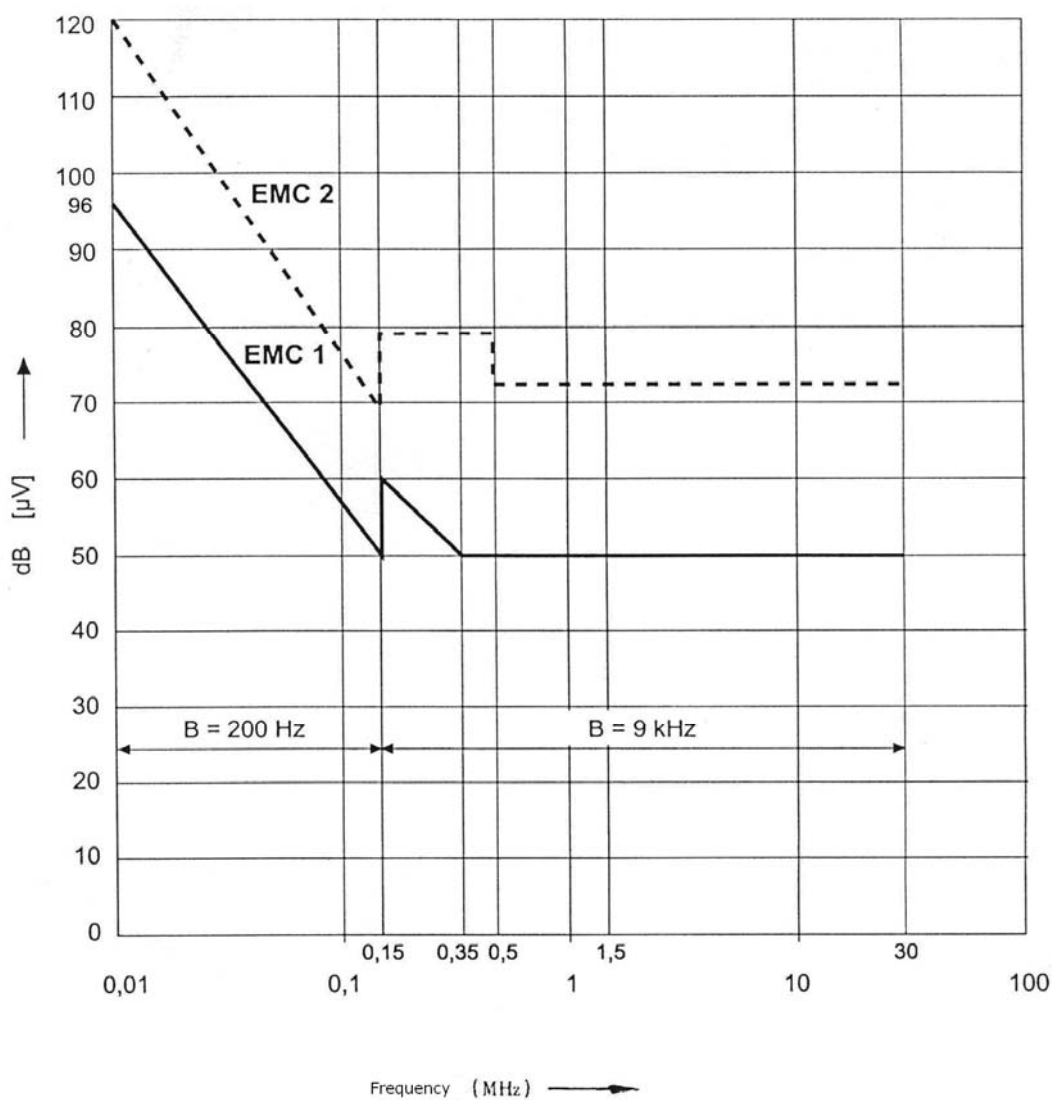

- B Measuring receiver bandwidth
- EMC1 EUT in bridge and open deck zone
- EMC2 EUT in general power distribution zone

Figure 3.2.5 Radio frequency terminal voltage limits for conducted emission

### 3.3 Measurement of radiated emissions from enclosure port

#### 3.3.1 Test purpose

This test serves to measure any signals radiated by an equipment other than through an antenna which can potentially disturb other equipment.

#### 3.3.2 Standards applied

CISPR Publication [16-2-3](#).

#### 3.3.3 Test conditions

- (1) During the test, the EUT is operated at its rated operational voltage and frequency (AC equipment).
- (2) Radiated emission is to be measured at a distance of 3 m from the enclosure port of the EUT of frequency range 150 kHz ~ 2 GHz.

#### 3.3.4 Method of test

- (1) The quasi-peak measuring receivers specified in [CISPR 16-2-3](#) are to be used. The receiver bandwidth in the frequency ranges 150 kHz~30 MHz and 156 MHz~165 MHz is to be 9 kHz and in the frequency ranges 30 MHz~156 MHz and 165 MHz~2 GHz is to be 120 kHz.
- (2) For frequencies from 150 kHz~30 MHz measurements are to be made of the magnetic H field. The correction factor for the antenna is to include the factor +51.5 dB to convert the magnetic field strength to equivalent electric field strength.
- (3) For frequencies above 30 MHz measurements are to be made of the electric field E.
- (4) The test site is to be compliant with [CISPR 16-2-3](#), using a metal ground plane and of dimensions to allow a measurement distance of 3 m.
- (5) The test antenna is to be placed at a distance of 3 m from the EUT. The center of the antenna is to be at least 1.5 m above the ground plane. The E-field antenna is to be adjusted in height and rotated to give horizontal and vertical polarization, one being parallel to the ground, in order to determine the maximum emission level. Also the antenna is to either be moved around the EUT, in order to determine the maximum emission level, or, alternatively, the EUT may be placed on a plane orthogonal to the test antenna at its mid-point and rotated to achieve the same effect.
- (6) Further information is given in [CISPR 16-2-3](#).

#### 3.3.5 Test result

In the frequency range 150 kHz~2 GHz, the electrical field strength measured at a distance of 3 m from the enclosure port of the EUT (the measured magnetic field strength is to be converted to equivalent electric field strength) is not to exceed the limits that are shown in Figure 3.3.5 and listed in Table 3.3.5, sorted by frequency range.

Field strength E measured at 3m

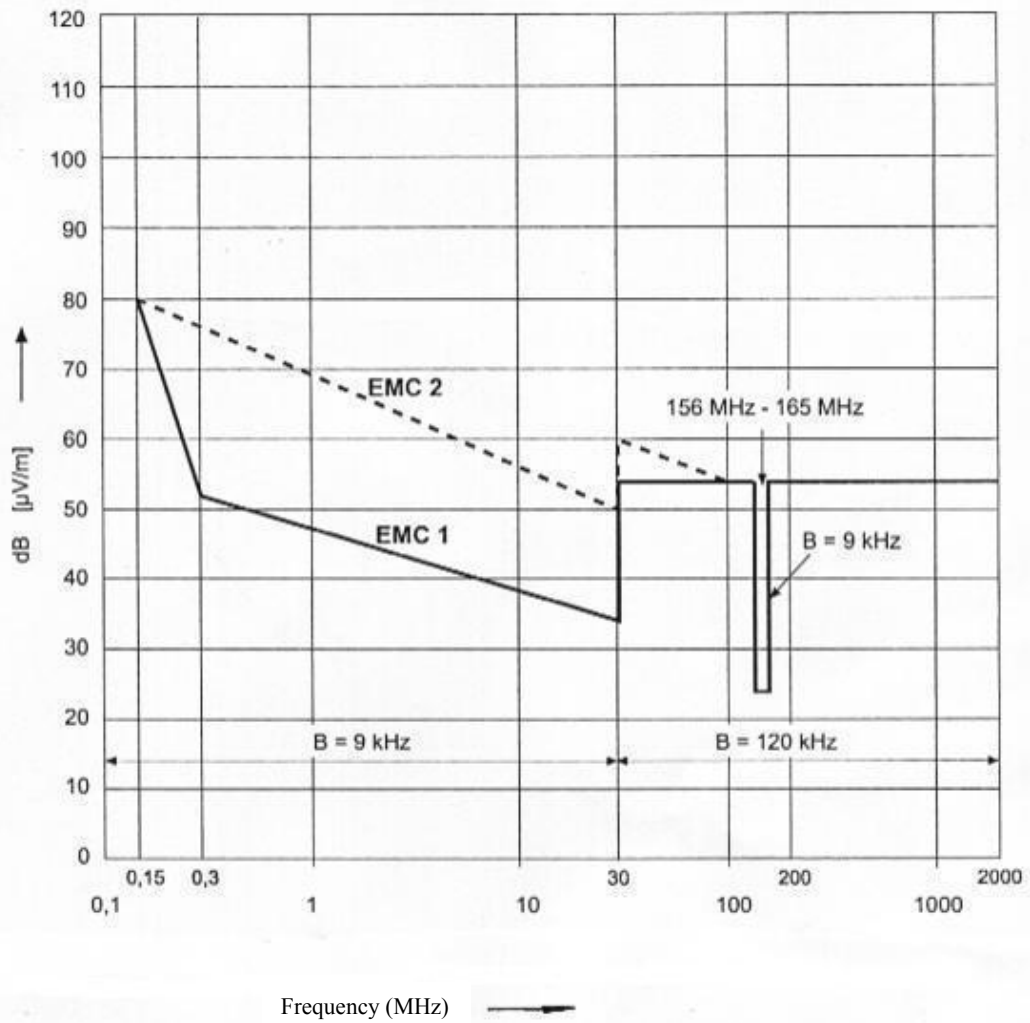

- B Measuring receiver bandwidth
- EMC1 EUT in bridge and open deck zone
- EMC2 EUT in general power distribution zone

Figure 3.3.5 Limits for radiated emissions from enclosure port

Limits for radiated emissions from enclosure port

Table 3.3.5

Site	Frequency range	Limits
Bridge and deck zone	150 kHz ~ 300 kHz	80 dB $\mu$ V/m ~ 52 dB $\mu$ V/m
	300 kHz ~ 30 MHz	52 dB $\mu$ V/m ~ 34 dB $\mu$ V/m
	30 MHz ~ 2 GHz Except for: 156 MHz~165 MHz	54 dB $\mu$ V/m 24 dB $\mu$ V/m <sup>u</sup>
General power distribution zone	150 kHz ~ 30 MHz	80 dB $\mu$ V/m ~ 50 dB $\mu$ V/m
	30 MHz ~ 100 MHz	60 dB $\mu$ V/m ~ 54 dB $\mu$ V/m
	100 MHz ~ 2 GHz Except for: 156 MHz ~ 165 MHz	54 dB $\mu$ V/m 24 dB $\mu$ V/m <sup>u</sup>
<p>① Alternatively the radiation limit at a distance of 3 m from the enclosure port over the frequency 156 MHz to 165 MHz shall be 30 dB<math>\mu</math>V/m peak.</p>		

### 3.4 Electrostatic discharge immunity test

#### 3.4.1 Test purpose

To simulate electrostatic discharge as may occur when persons carry electrostatic by touching fibre carpets, and vinyl garments, etc.

#### 3.4.2 Standard applied

IEC Publication 61000-4-2

#### 3.4.3 Test conditions

(1) During the test, the EUT operates at its rated operational voltage and frequency (AC equipment).

(2) Electrostatic discharge parameters

Test voltage: Contact discharge 6 kV; air discharge 2 kV, 4kV, 8 kV;

Interval between single discharges:  $\geq 1$ s;

Number of pulses: 10 per polarity.

#### 3.4.4 Method of test

(1) The EUT is to be installed on a metallic ground plane and be insulated from the plane. The plane is to be big enough so that there is a room of 0.5 m around the EUT.

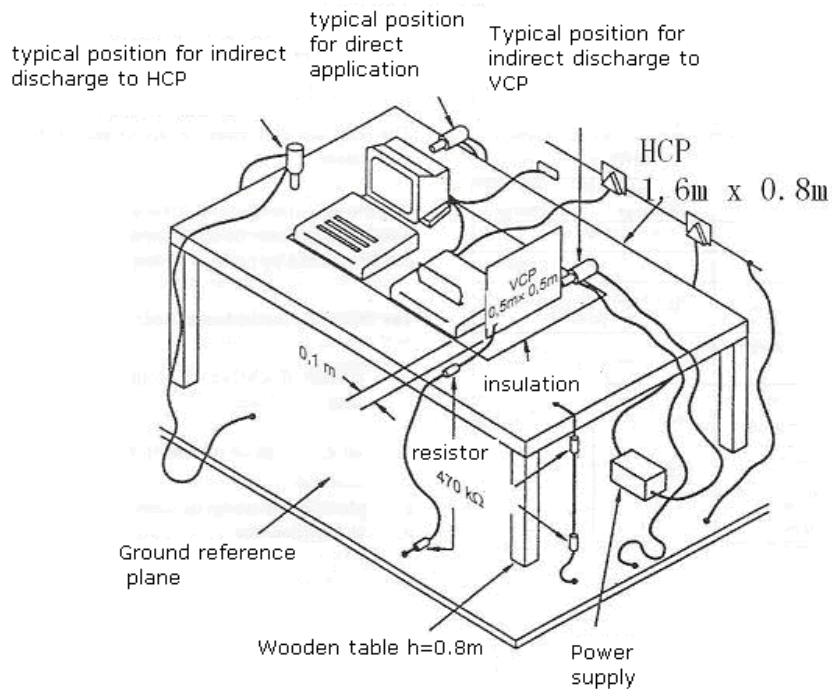

Figure 3.4.4a Example of test set-up for table-top equipment

## (2) Direct application of discharges

The application of electrostatic discharges is to be confined to the points and surfaces that can normally be reached by the operator as specified in IEC Publication 61000-4-2. During test the electrostatic discharge is to be held perpendicular to the surface to which the discharge is applied. The points to which the discharge should be applied may be selected by means of an exploration carried out at a repetition rate of 20 discharges per second or more. On preselected points at least ten single discharges in both positive polarity and negative polarity is to be applied. The interval between successive single discharges is to be at least 1s so that any failure of EUT can be observed.

The contact discharge is applicable to conducting surfaces and air discharge is applicable to insulating surfaces.

## (3) Indirect application of the discharge

Discharges to objects placed or installed near the EUT are to be simulated by applying 10 single discharges (in both positive and negative polarities) to the horizontal coupling plane (HCP), at a distance of 0.1 m from each side of the EUT (see Figure 3.4.4a). And another 10 single discharges are to be applied to the center of each edge of the vertical coupling plane (VCP) (of dimensions  $0.5\text{ m} \times 0.5\text{ m}$ ) (see Figure 3.4.4a and Figure 3.4.4b). Discharges are to be applied to the coupling plane with sufficient different positions such that the four faces of the EUT are completely illuminated.

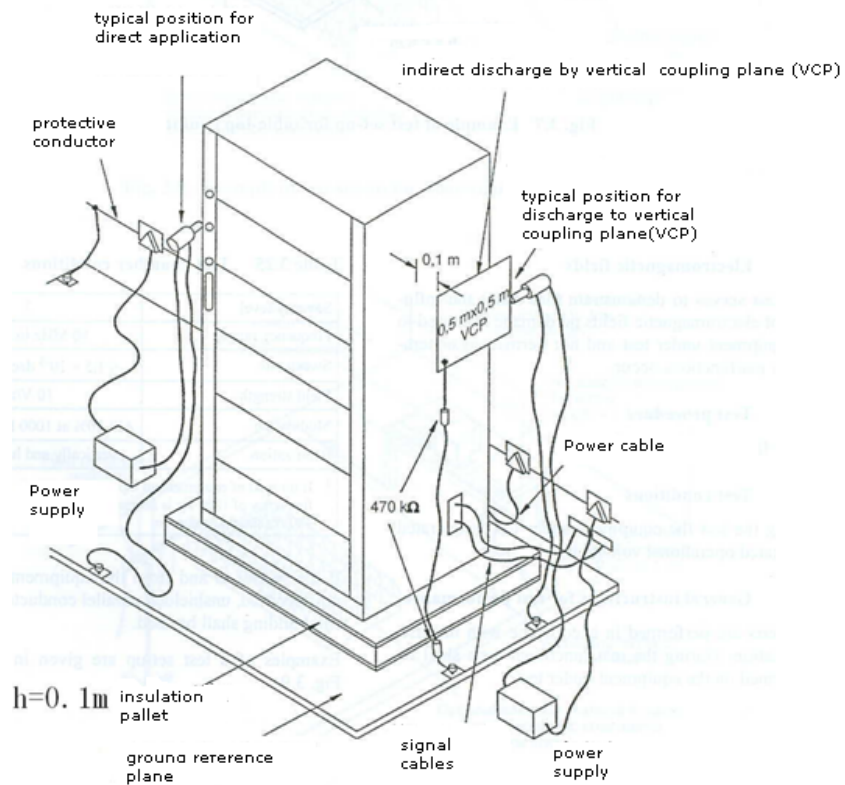

Figure 3.4.4b Example of test set-up for floor-standing equipment

(4) Further information is given in IEC Publication 61000-4-2.

(5) See Figure 3.4.4a for example of test set-up for table-top equipment and Figure 3.4.4b for example of test set-up for floor-standing equipment

### 3.4.5 Test result

The EUT performance check result is to fulfill the requirements of performance criterion B as specified in Chapter 1 during and after the test.

## 3.5 Test of Immunity to radiated, radiofrequency, electromagnetic field

### 3.5.1 Test Purpose

This test simulates the radiated electromagnetic field effects of radio transmitters at frequencies above 80 MHz, such as the ship's VHF transmitter and of hand-held portable radio equipment, close to the equipment.

### 3.5.2 Standard applied

IEC Publication 61000-4-3.

### 3.5.3 Test conditions

(1) During the test, the EUT is operated at its rated operational voltage and frequency (AC equipment).

(2) Test Parameters

- Frequency range: 80 MHz  $\sim$  2 GHz;  
Modulation frequency: 1000 Hz (or 400 Hz<sup>①</sup>);  
Modulation: 80 %;  
Field strength: 10 V/m (non modulated);  
Frequency sweep rate :  $\leq 1.5 \times 10^{-3}$  dec/s<sup>②</sup>.

#### 3.5.4 Method of test

- (1) The EUT is to be installed in a suitably shielded room or anechoic chamber of a size commensurate with the size of the EUT. The EUT is to be set in the area of uniform field and insulated from the floor by a non-metallic support. The configuration of the EUT and associated cables is to be recorded in the test report.
- (2) If the wiring to and from the EUT is not specified by the manufacturer, unshielded parallel conductors are to be used and left exposed to the electromagnetic fields for a distance of 1 m from the EUT.
- (3) The generating antenna is to face each of the four sides of the EUT. When equipment can be used in different orientations (that is vertical or horizontal), the test is to be performed on all sides. The specified frequency range is to be swept at a rate that is slow enough ( $\leq 1.5 \times 10^{-3}$  dec/s) to allow the detection of any malfunction of the EUT. Any sensitive frequency is to be analyzed separately.
- (4) Further information is given in IEC publication 61000-4-3.
- (5) Example of test set-up for floor-standing equipment is given in Figure 3.5.4a and for table-top equipment is given in Figure 3.5.4b.

---

<sup>①</sup> If for tests of equipment an input signal with a modulation frequency of 1000 Hz is necessary a modulation frequency of 400Hz may be chosen.

<sup>②</sup> “dec / s”: of which “dec” is the abbreviation of “decades” namely the ratio of high frequency to low frequency is 10.

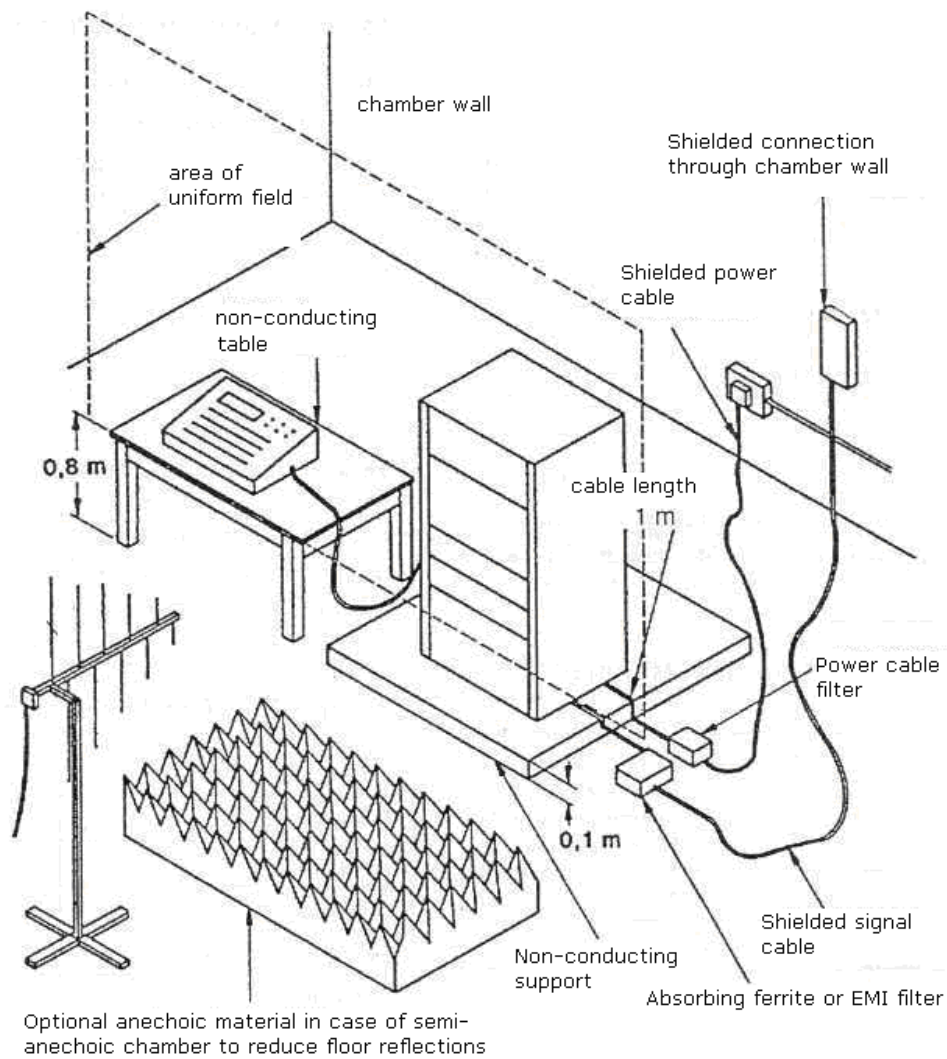

Note: Anechoic lining material has been omitted from walls for clarity.

Figure 3.5.4a Example of test set-up for floor-standing equipment

### 3.5.5 Test result

The EUT performance check result is to fulfill the requirements of performance criterion A as specified in Chapter 1 during and after the test.

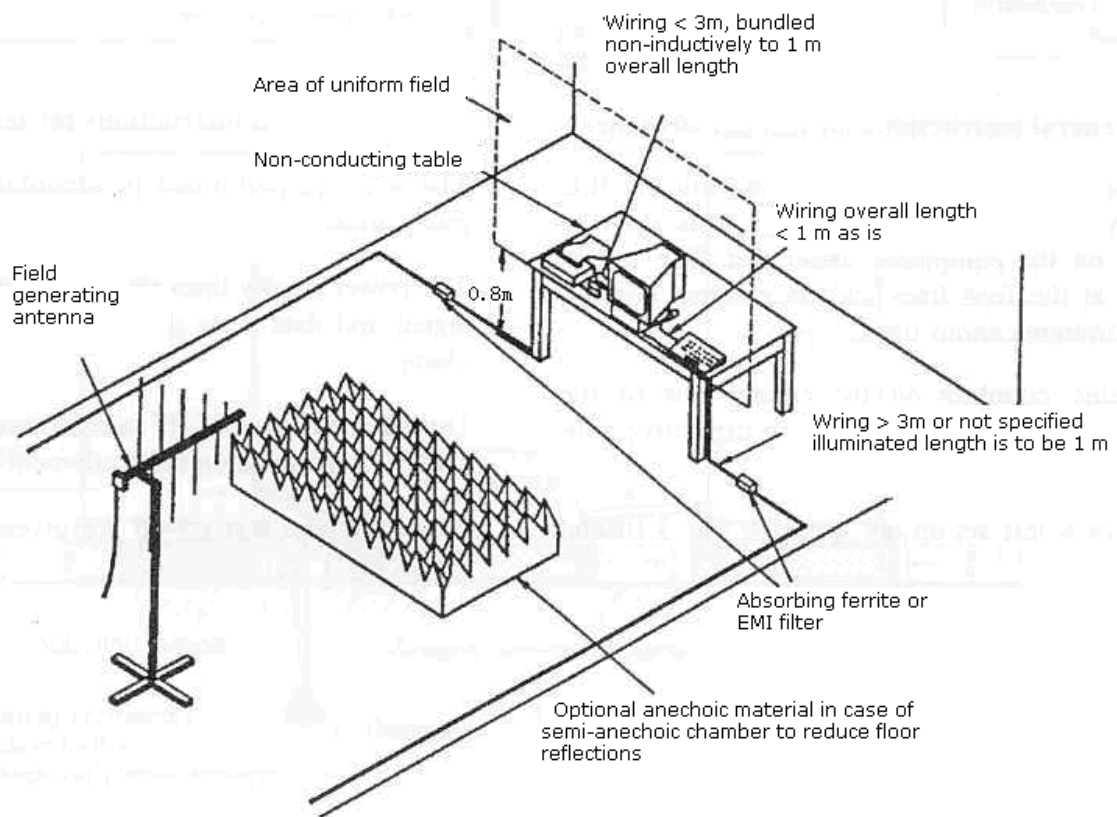

Figure 3.5.4b Example of test set-up for table-top equipment

### 3.6 Electrical fast transients/burst immunity test

#### 3.6.1 Test purpose

This test simulates the fast, low-energy transients produced by equipment switching which causes arcing at contacts.

#### 3.6.2 Standard applied

IEC Publication 61000-4-4

#### 3.6.3 Testing conditions

(1) During the test, the EUT is to operate at its rated operational voltage and frequency (AC equipment).

(2) Test parameters

Single pulse rise time: 5 ns (value between 10%~90%);

Single pulse width: 50 ns (50% value);

Peak (open circuit): 2 kV on power supply line (line/earth);

1 kV on control and signal line (line/earth);

Pulse repetition rate: 5 kHz at 1 kV, 2.5 kHz at 2 kV;

Burst-duration: 15 ms;

Burst-period: 300 ms;  
 Duration per polarity: 5 min.

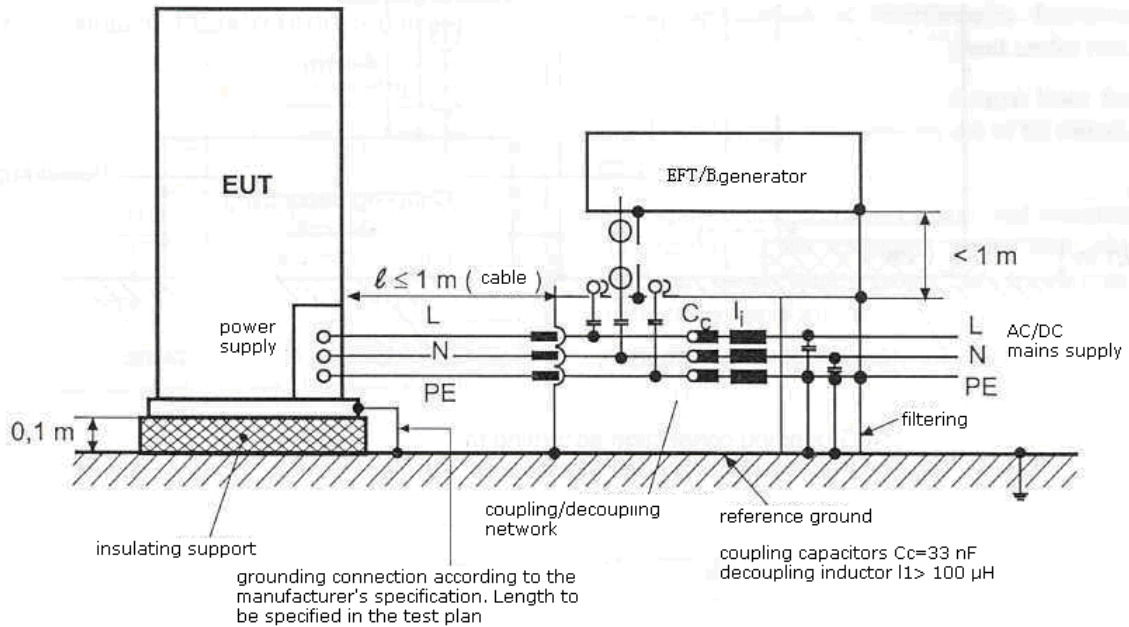

Figure 3.6.4a

Example of test set-up for direct coupling of the test voltage to power supply ports/terminals

### 3.6.4 Method of test

- (1) The test is to be carried out in accordance with the following requirements:
  - ① using a test signal generator complying with IEC publication 61000-4-4;
  - ② using a coupling /decoupling network complying with IEC publication 61000-4-4 for power lines;
  - ③ using a capacitive coupling clamp complying with IEC publication 61000-4-4 for signal and control lines.
- (2) Further information is given in IEC publication 61000-4-4.
- (3) Example of test set-up for direct coupling of the test voltage to power supply ports/terminals is given in Figure 3.6.4a and for application of the test voltage by the capacitive coupling clamp is given in Figure 3.6.4b.

### 3.6.5 Test result

The EUT performance check result is to fulfill the requirements of performance criterion B as specified in Chapter 1 during and after the test.

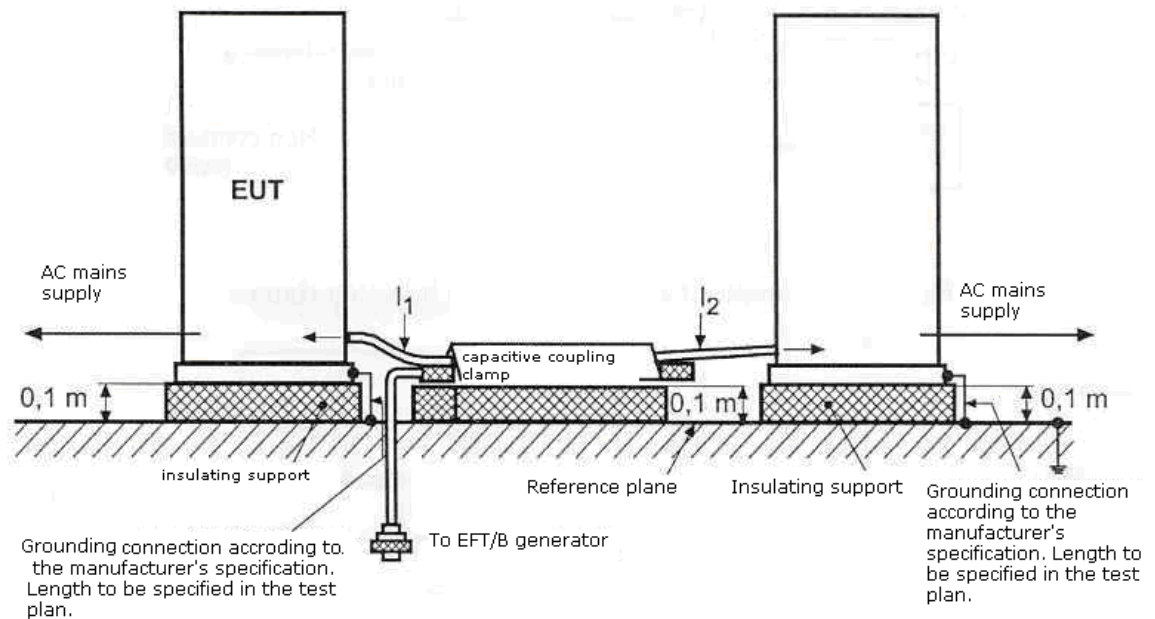

Figure 3.6.4b Example of test set-up for application of the test voltage by the capacitive coupling clamp

### 3.7 Surge immunity test

#### 3.7.1 Test purpose

This test simulates the high-energy disturbance which may be produced on power lines by switching “ON” or “OFF” high power inductive consumers.

#### 3.7.2 Standard applied

IEC publication 61000-4-5

#### 3.7.3 Test conditions

(1) During the test, the EUT is to operate at its rated operational voltage and frequency (AC equipment).

#### (2) Test parameters

Test applicable to AC and DC power ports

Open-circuit voltage:

Pulse rise time: 1.2  $\mu$ s (front time)

Pulse width: 50  $\mu$ s (time to half value)

Amplitude (peak): 1kV line/earth; 0.5kV line/line

Short-circuit current:

Pulse rise time: 8  $\mu$ s (front time)

Pulse width: 20  $\mu$ s (time to half value)

Repetition rate:  $\geq 1$  pulse/min

No. of pulses: 5 per polarity

Application: continuous.

### 3.7.4 Method of test

(1) The test is to be carried out in accordance with IEC publication 61000-4-5 and the parameters specified in 3.7.3 using a combination wave signal generator in combination with a coupling/decoupling network complying with the relevant requirements in IEC 61000-4-5.

(2) Further information is given in IEC publication 61000-4-5.

(3) Example of test set-up for line-to-earth coupling on power supply lines is given in Figure 3.7.4a and for line-to-line in Figure 3.7.4b.

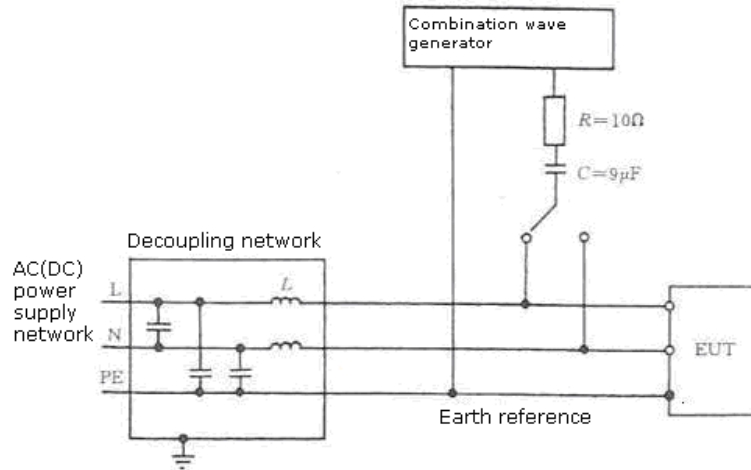

Figure 3.7.4a Example of test set-up for line-to-earth coupling on power supply lines

### 3.7.5 Test result

The EUT performance check result is to fulfill the requirements of performance criterion B as specified in Chapter 1 during and after the test.

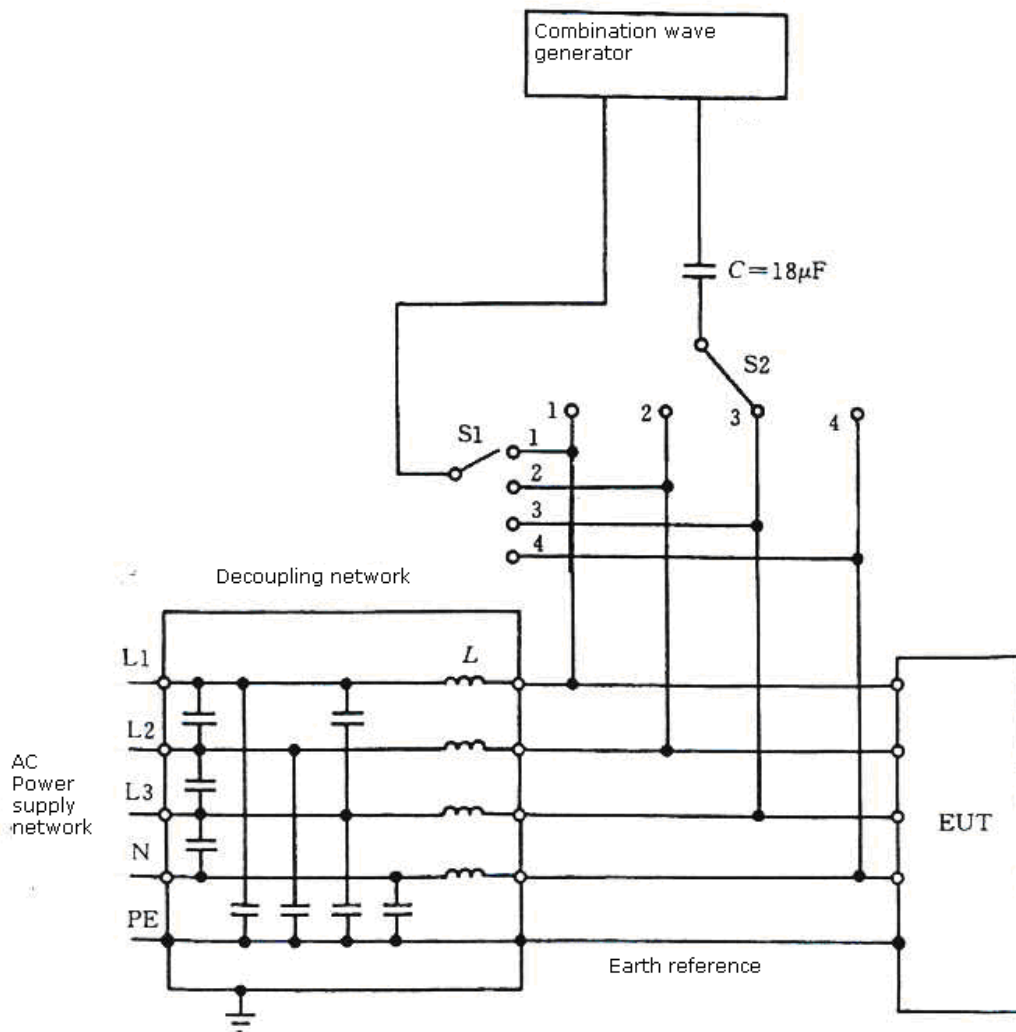

Figure 3.7.4b Example of test set-up for line-to-line coupling on power supply lines

### 3.8 Test of immunity to conducted low frequency interference

#### 3.8.1 Test purpose

This test simulates the effects from the power supply harmonics on A.C. supply and alternator ripple on D.C. supplies.

#### 3.8.2 Test conditions

(1) During the test, the EUT is to operate at its rated operational voltage and frequency (A.C. equipment), and, where necessary, at its rated current.

(2) Test parameters

① Test voltage value of A.C. powered equipment (r.m.s);

up to 15th harmonics:  $10\%U_n$ ;

15th to 100th harmonics: from  $10\%U_n$  down to  $1\%U_n$ ;

100th to 200th harmonics:  $1\%U_n$ .

As in Figure 3.8.2, but min 3 V r.m.s;

② Test voltage value of DC powered equipment (sinusoidal r.m.s);

Test voltage (r.m.s):  $10\%U_n$ ;

Frequency range: 50Hz~10kHz;

③ A maximum of 2 W to the power supply lines may be applied during test. For keeping max. 2W, the voltage of the test signal may be lower.

### 3.8.3 Method of test

(1) The typical test set-ups for A.C. or D.C. powered EUT are shown in Figure 3.8.3.

(2) The low frequency disturbance signals as required in 3.8.3(2) and shown in Figure 3.8.3 are to be superimposed on the power supply lines of EUT, and the frequency sweep is to be carried out at a rate low enough within the required range, in order to detect any malfunction of EUT.

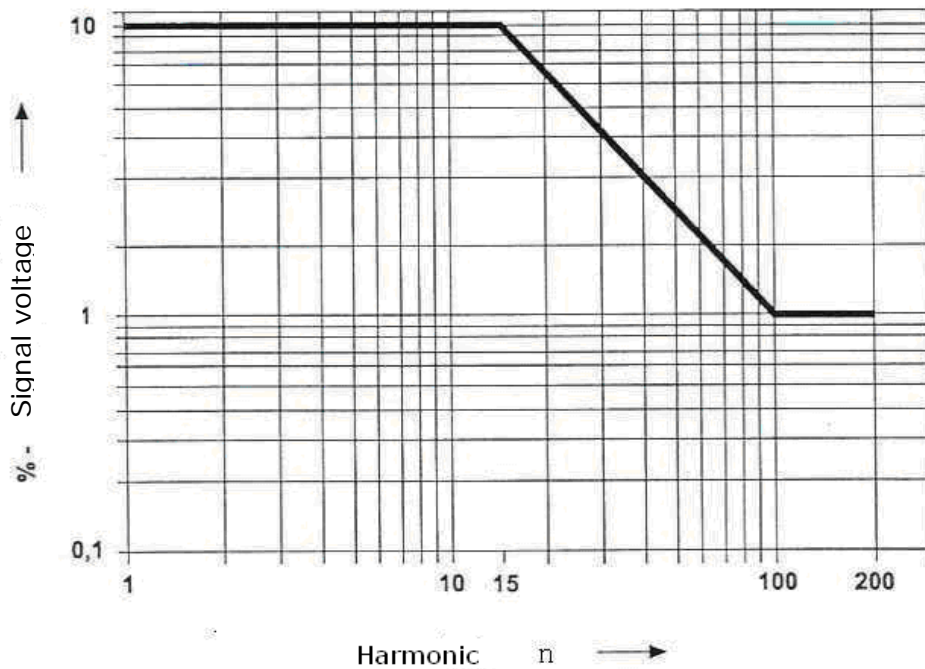

Figure 3.8.2

Signal voltage for A.C. equipment--test of immunity to conducted low frequency interference

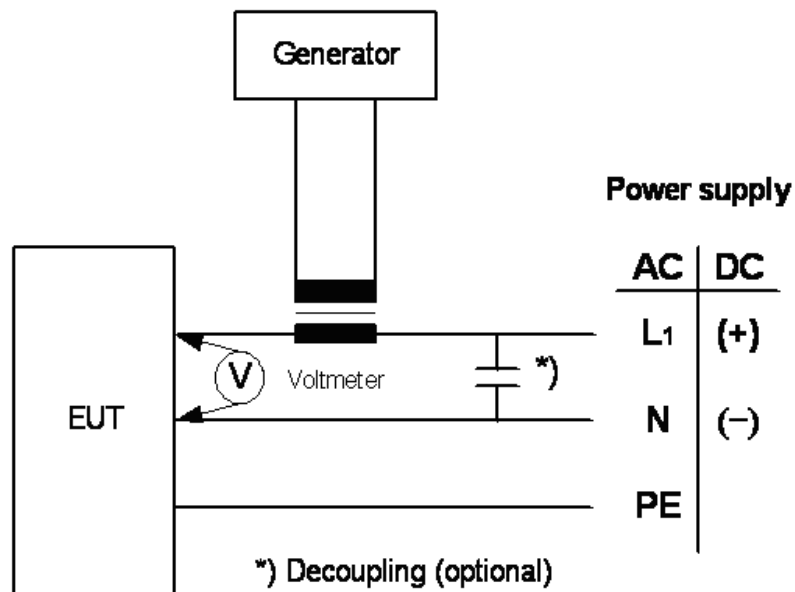

Figure 3.8.3 Typical test set-up for test of immunity to conducted low frequency interference

#### 3.8.4 Test result

The EUT performance check result is to fulfill the requirements of performance criterion A as specified in Chapter 1 during and after the test.

### 3.9 Test of immunity to conducted disturbances induced by radio-frequency fields

#### 3.9.1 Test purpose

This test simulates the effects of disturbances induced in power, signal and control lines from radio transmitters at frequencies below 80MHz.

#### 3.9.2 Standard applied

IEC publication 61000-4-6.

#### 3.9.3 Test conditions

(1) During the test, the EUT is to operate at its rated operational voltage and frequency (AC equipment).

(2) Test parameters

Frequency range: 150 kHz~80 MHz;

Voltage (open circuit): 3 V (r.m.s);

Modulation frequency: 1000 Hz (or 400 Hz<sup>①</sup>);

Modulation depth: 80%;

Frequency sweep range:  $\leq 1.5 \times 10^{-3}$  dec/s.

<sup>①</sup> If for tests of equipment an input signal with a modulation frequency of 1000 Hz is necessary a modulation frequency of 400Hz may be chosen.

For equipment placed on bridge and deck zone:

Disturbance signals, of voltage 10 V (r.m.s), with the same modulation frequency and depth, are to be applied for the test at spot frequencies 2, 3, 4, 6.2, 8.2, 12.6, 16.5, 18.8, 22 and 25 MHz.

### 3.9.4 Method of test

(1) The EUT is to be placed on an insulating support of 0.1 m high above a ground reference plane. The auxiliary equipment (AE) necessary to provide the EUT with power, and the signals required for normal operation is to be connected by cables, which are also to be connected in series with appropriate coupling and decoupling networks (CDNs) on the ground reference plane at a distance between 0.1 m and 0.3 m from the EUT. Alternative injection clamps specified in IEC 61000-4-6 may be used if the use of CDNs is not possible.

(2) The test is to be performed with the test generator connected to each of the CDNs in turn, while the other non-excited radio frequency input ports to the CDNs are terminated by a 50 Ω load resistor. The test generator level is to be set for the CDN with the generator connected and the AE and the EUT replaced by resistor of value 150 Ω.

(3) The frequency sweep rate is not to exceed  $1.5 \times 10^{-3}$  dec/s in order to allow for the detection of any malfunction of the EUT.

(4) Further information is given in IEC 61000-4-6.

(5) Example of test set-up with a single-unit system for test equipment is given in Figure 3.9.4a and of a test set-up using injection clamps is given in Figure 3.9.4b.

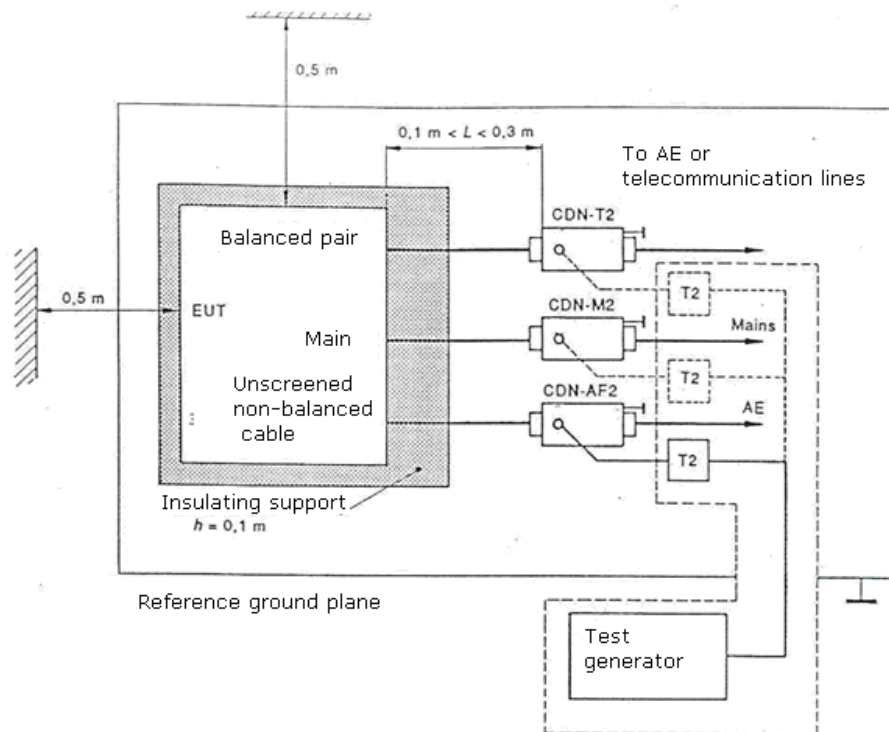

Figure 3.9.4a Example of test set-up with a single-unit system for test equipment

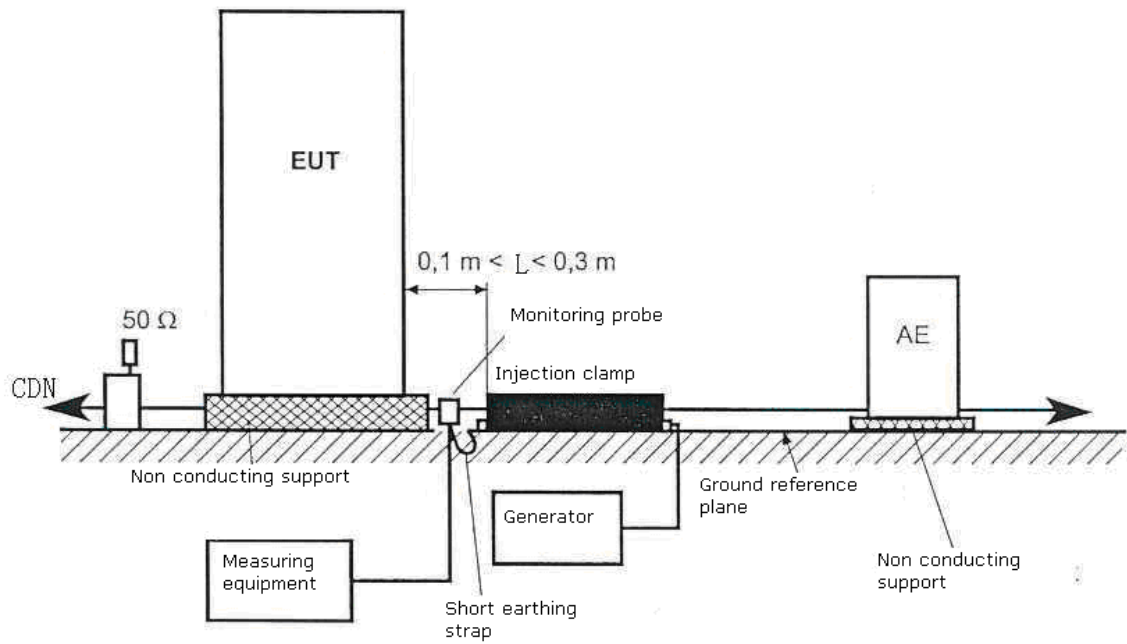

Figure 3.9.4b Example of a test set-up using injection clamps

### 3.9.5 Test result

The EUT performance check result is to fulfill the requirements of performance criterion A as specified in Chapter 1 during and after the test.

## Chapter 4 Maritime Navigation and Radio communication Equipment and Systems

### 4.1 General requirements

4.1.1 Type approval tests for maritime navigation and radio communication equipment and systems are to be carried out in accordance with IEC Publication 60945. Type approval tests for maritime navigation and radio communication equipment and systems that are specified by SOLAS are to be carried out in compliance with the relevant performance and test standards adopted by IMO and IEC accordingly.

### 4.2 Type approval tests

4.2.1 Type approval tests for marine navigation and radio communication equipment and systems are shown in Table 4.2.1. The latest version of IEC Publication 60945 is to be relied on in case of any discrepancy.

Type approval tests

Table 4.2.1

Test category	Equipment	Portable equipment	Indoor equipment	Outdoor equipment	Immersion equipment <sup>①</sup>	Paragraphs in IEC60945 Publication (2002)
	Test					
General	Operational check	X	X	X	X	6.1 ~ 6.4
	Performance test	X	X	X	X	5.1
Power supply	Extreme power supply variation	X	X	X	X	7.1, 5.2.2
	Excessive conditions <sup>②</sup>	X	X	X	X	7.2, 5.2.3
	Power supply short-term variation <sup>③</sup>	—	X	X	X	7.3, 10.7
	Power supply failure <sup>③</sup>	—	X	X	X	7.4, 10.8
Environmental conditions	Dry heat	X	X	X	X <sup>④</sup>	8.2
	Damp heat	X	X	X	—	8.3
	Low temperature <sup>⑤</sup>	X	X	X	—	8.4
	Thermal shock	X	—	—	—	8.5
	Drop	X	—	—	—	8.6.1, 8.6.2
	Vibration	X	X	X	X	8.7
	Rain and spray	—	—	X	—	8.8
	Immersion 1	—	—	—	X	8.9.1
	Immersion 2	X	—	—	—	8.9.2
	Temporary immersion	X	—	—	—	8.9.3
	Solar radiation <sup>⑥</sup>	X	—	—	—	8.10
	Oil resistance <sup>⑥</sup>	X	—	—	—	8.11
Salt mist (corrosion) <sup>⑥</sup>	X	X	X	X	8.12	

Table 4.2.1(continued)

Test category	Equipment	Portable equipment	Indoor equipment	Outdoor equipment	Immersion equipment <sup>①</sup>	Paragraphs in IEC60945 Publication (2002)
	Test					
Electromagnetic compatibility	Conducted emissions	X	X	X	X	9.2
	Radiated emissions from enclosure port	—	X	X	X	9.3
	immunity to conducted disturbances induced by radio-frequency fields	—	X	X	X	10.3
	Immunity to radiated, radiofrequency, electromagnetic field	X	X	X	—	10.4
	Electrical fast transients/burst immunity t	—	X	X	X	10.5
	Surge immunity	—	X	X	X	10.6
	Electrostatic discharge immunity	X	X	X	—	10.9
Special purpose	Acoustic noise and signals <sup>⑦</sup>	—	X	X	—	11.1
	Compass safe distance	X	X	X	—	11.2
Safety precautions	Protection against accidental access to dangerous voltage	X	X	X	X	12.1
	Electromagnetic radio frequency radiation	X	X	X	X	12.2
	Emission from visual display unit(VDU) <sup>⑧</sup>	X	X	X	X	12.3
	X-radiation <sup>⑧</sup>	X	X	X	X	12.4

Note: ① Including the equipment in continuous contact with sea water.

② Excessive conditions generally include the followings: voltage variation exceeding the value required in 5.2.2 of IEC 60945, current exceeding the normal operational current and reversal of the power supply polarity or phase sequence.

③ Power supply short-term variation test is not applicable to D.C. powered equipment. Power supply failure test is not applicable to equipment intended for operation from battery power sources or fitted with back-up batteries.

④ For immersion equipment, a storage test at a temperature of +70°C is needed only.

⑤ Portable marine navigation and radio communication equipment are to be additionally subject to low temperature storage test at -30°C±3°C.

⑥ The solar radiation test, oil resistance test and salt mist (corrosion) test may be waived where the manufacturer is able to produce evidence that the components, materials and finishes employed in the equipment would satisfy the test.

⑦ Acoustic noise and signals test is only for equipment in wheelhouses or bridge wings.

⑧ The test may be waived where the manufacturer is able to produce evidence that the equipment would satisfy the test.

## Appendix A International standards and China national standards referred to in the Guidelines

No.	International standards	China national standards
1	IEC60068-2-1 "Environmental testing Part 2: Tests-Tests A: Cold"	GB/T2423.1 "Basic Environmental Testing Procedures for Electric and Electronic Products" Tests A: Cold
2	IEC-68-2-2 "Environmental testing Part 2: Tests-Tests B: Dry heat "	GB/T 2423.2"Basic Environmental Testing Procedures for Electric and Electronic Products" Tests B: Dry heat
3	IEC60068-2-6 "Environmental testing – Part2: Tests-Tests Fc: Vibration (sinusoidal)"	GB/T2423.10"Basic Environmental Testing Procedures for Electric and Electronic Products" Part 2: Test method Test Fc and Guidance: Vibration (sinusoidal)
4	IEC60068-2-30 "Environmental testing – Part 2:Tests-Test Db:Damp heat,cyclic "	GB/T2423.4"Basic Environmental Testing Procedures for Electric and Electronic Products" Test Db: damp heat, cyclic
5	IEC60068-2-78 "Environmental testing – Part 2-78: Tests-Test Cab:Damp heat,steady state "	GB/T2423.3"Basic Environmental Testing Procedures for Electric and Electronic Products" Test Cab: Test method for Damp heat, steady state
6	IEC60068-2-11 "Environmental testing – Part 2: Tests-Test Ka: Salt mist "	GB/T 2423.17"Basic Environmental Testing Procedures for Electric and Electronic Products" Test Ka: Test method for salt mist
7	IEC60068-2-52 "Environmental testing – Part 2: Tests-Test Kb-salt mist, cyclic(sodium chloride solution)"	GB/T 2423.18"Basic Environmental Testing Procedures for Electric and Electronic Products" Test Kb: Test method for salt mist, cyclic(sodium chloride solution)
8	IEC60092-101 "Electrical installations in ships– Part 101: Definitions and general requirements "	GB/T 6994 "General Requirements for Electrical Installations in Ships"
9	CISPR 16-2-1"Specification for radio disturbance and immunity measuring apparatus and methods — Part 2-1: Methods of measurement of disturbances and immunity – Conducted disturbance measurements" CISPR16-2-3 " Specification for radio disturbance and immunity measuring apparatus and methods – Part 2-3: Methods of measurement of disturbances and immunity – Radiated disturbance measurements "	GB/T6113.1 "Specifications for Radio Disturbance and Immunity Measuring Apparatus" GB/T6113.2"Methods for Radio Disturbance and Immunity Measuring "
10	IEC61000-4-2 "Electromagnetic Compatibility (EMC) Part 4: Testing and measurement techniques – Section 2: Electrostatic discharge test"	GB/T17626.2 "Electromagnetic Compatibility-Testing and measurement techniques -Electrostatic discharge immunity test"
11	IEC61000-4-3 "Electromagnetic compatibility (EMC) Part 4: Testing and measurement techniques – Section 3: Radiated, radio-frequency, electromagnetic field immunity test"	GB/T17626.3 "Electromagnetic Compatibility -Testing and measurement techniques- Radiated, radio-frequency, electromagnetic field immunity test"
12	IEC61000-4-4 "Electromagnetic compatibility (EMC) Part 4: Testing and measurement techniques – Section 4: Electrical fast transient/burst immunity test"	GB/T17626.4"Electromagnetic Compatibility -Testing and measurement techniques- Electrical fast transient/burst immunity test"
13	IEC61000-4-5 "Electromagnetic compatibility (EMC) Part 4: Testing and measurement techniques – Section 5: Surge immunity test"	GB/T17626.5"Electromagnetic Compatibility -Testing and measurement techniques- Surge immunity test"
14	IEC61000-4-6 "Electromagnetic compatibility (EMC) Part 4: Testing and measurement techniques – Section 6: immunity to conducted disturbances, Induced by radio-frequency fields"	GB/T17626.6"Electromagnetic Compatibility -Testing and measurement techniques- immunity to conducted disturbances, Induced by radio-frequency fields"