



Guideline No.P-07 (201510)

P-07 Mechanical Joint

Issued date: 20th October 2015

©China Classification Society

Foreword

This Guideline is a part of CCS Rules, which contains technical requirements, inspection and testing criteria related to classification and statutory survey of marine products.

This Guideline is published and updated by CCS and can be found through <http://www.ccs.org.cn>. Comments or suggestions can be sent by email to ps@ccs.org.cn.

Historical versions and release date:

Main changes and effective date:

CONTENTS

1 Application..... 4

2 Basis for approval and inspection 4

3 Definitions..... 4

4 Plans and documents 4

5 Materials and components..... 6

6 Technical requirements 6

7 Type test..... 7

8 Unit/batch inspection 15

Mechanical Joint

1 Application

1.1 This Guideline applies to the mechanical joints defined in 2.5.3, Chapter 2 of Part Three of *CCS Rules for Classification of Sea-going Steel Ships*, including type approval and product inspection for all types of ship piping joints, compression couplings and slip-on joints.

1.2 This Guideline may also be reference by other mechanical joints with similar construction.

1.3 The type approval performed according to the nationally or internationally recognized standards equivalent to this Guideline is acceptable.

2 Basis for approval and inspection

2.1 Chapter 2, Part Three of *CCS Rules for Classification of Sea-Going Steel Ships*

2.2 IACS UR P2.7.4, UR P 2.7.11.

2.3 ISO19921: *Ships and Marine Technology — Fire Test of Metallic Pipe Components with Resilient and Elastomeric Seals — Test Methods*

2.4 ISO19922: *Ships and Marine Technology — Fire Test of Metallic Pipe Components with Resilient and Elastomeric Seals — Requirements Imposed on the Test Bench*

3 Definitions

3.1 The definitions given in *CCS Rules for Classification of Sea-going Steel Ships* apply to this Guideline.

3.2 The terms used in this Guideline are defined as follows:

- (1) Mechanical joint means the construction connecting different pipe sections together with mechanical methods for ship pipelines.
- (2) Maximum design pressure generally means the maximum pressure and vacuum degree which the joint can bear at normal temperature.
- (3) Maximum and minimum design temperatures mean the temperature range which the joint can bear in normal operation.

4 Plans and documents

4.1 The following plans and documents are to be submitted to CCS for approval:

4.1.1 Documents of main technical specifications:

- (1) Maximum design pressure (pressure and vacuum)
- (2) Maximum and minimum design temperatures;
- (3) Transmission medium;
- (4) Proposed service;
- (5) Maximum axial, radial and angular deviations allowed by the manufacturer;
- (6) Installation instructions.

4.1.2 Detailed introduction of products;

4.1.3 Typical section plan (including all dimensions necessary for the assessment of the joint design);

4.1.4 A list and an introduction of the physicochemical properties of raw materials of all parts;

4.1.5 Test procedures and relevant test reports or other previous relevant tests;

Note: For joints manufactured according to national standards which include detailed section plans, the typical section plan is not necessary to be submitted again.

4.2 The following documents are to be submitted to CCS for information:

4.2.1 Parts plans (where necessary);

4.3 The following approval documents and type approval test program including the scope of application for approval, approval bases, selection of samples, test items and acceptance criteria are to be submitted by the manufacturer applying for type approval:

- (1) Factory profile: Name, address, production history, capacity, technicians and inspectors, main products, affiliation, trademark, etc;
- (2) List of products to be approved;
- (3) Main production equipment;
- (4) Main test equipment;
- (5) A brief description on the production technology of product to be approved;
- (6) Quality management document;
- (7) Registration certificate;

- (8) Qualification certificate and/or production license;
- (9) Sample of product quality certificate;
- (10) Quality control plan (where applicable).

5 Materials and components

5.1 Materials and components are to be controlled according to relevant requirements of the CCS Rules currently in effect;

5.2 The body material and sealing ring of outsourced mechanical joints must have quality certificate of the plant.

5.3 The body materials of joints for Class I and II piping systems are to be manufactured by the plant approved by CCS or have product certificate issued by CCS or be re-tested.

6 Technical requirements

6.1 The use of mechanical joints is to be in compliance with the provisions of Table 2.5.3.1 (2) and Table 2.5.3.1 (3) of Chapter 2, Part Three of *Rules for Classification of Sea-going Steel Ships*. Other types of mechanical joints are to be used with the approval of CCS.

6.2 The construction of mechanical joints is to be such as to, after installation on board, protect against sealing failure caused by pressure pulsation, pipeline vibration, temperature variation and other similar adverse effects.

6.3 Mechanical joints are to be able to bear internal and external pressure. Mechanical joints for suction line are to be able to work normally at a certain vacuum degree.

6.4 Mechanical joints are to have enough strength. As there are different types of mechanical joints with different constructions, this Guideline does not limit the calculation methods and only focuses on type test results, provided that the wall thickness of joints are at least not less than the minimum wall thickness required by the Rules. Where the pipe wall thickness is reduced due to the use of engaging ring or components of other constructions, consideration is to be given when the minimum pipe wall thickness under design pressure is determined.

6.5 Mechanical joints with fire resistance requirement are to be subjected to fire test.

6.6 Mechanical joints are to be subjected to four times the design pressure in burst pressure test.

6.7 Materials

- (1) Materials and tests of mechanical joints of Class I and II piping systems are to be in compliance with relevant requirements of CCS Rules for Materials and Welding.
- (2) Materials and tests of mechanical joints of Class III piping system are to be in compliance with applicable standards.

- (3) Materials of mechanical joints are to be compatible with the materials of piping system and internal and external medium.
- (4) The proof that all components (including body materials and sealing construction) are to be able to withstand the corrosion of working medium under the specified design pressure and temperature is to be submitted by the manufacturer;
- (5) For joints with design temperature of over 50 °C, the maximum permissible working pressure under variable temperatures is to be modified according to the mechanical properties under high temperature of materials by the manufacturer.

6.8 Weld seams of mechanical joints are to be subjected to non-destructive test according to the following requirements:

- (1) All butt-welded joints of the pipes with outside diameter of more than 75 mm in Class I piping system are to be subjected to radiographic inspection.
- (2) 10% of the butt-welded joints of the pipes with outside diameter of more than 100 mm in Class II piping system and the butt-welded joints of the pipes with outside diameter up to 75 mm in Class I piping system are to be sampled for radiographic inspection.

7 Type test

7.1 Purpose of test

The test is intended to prove that the pipeline joints have the ability to work under the proposed service condition. The test scope and type (e.g. applicability test), test order and sample size are to be submitted for approval and to be determined according to the design requirements of joints and proposed service condition specified by this Appendix. Unless otherwise stated, water or oil is to be used as the test liquid.

7.2 Selection of typical sample

Test samples are to be randomly taken from the production line or the stock according to the following requirements:

- (1) Where joint types to be approved have different dimensions and specifications, then at least three typical samples of different dimensions are to be taken for each type of joint.
- (2) For joints of the same type and structural dimensions but different materials, those made of materials with lower strength and plasticity are to be selected for the test.
- (3) The sample with the highest pressure grade is generally selected. Special considerations are to be paid to products which easily leak under low pressure.

7.3 Assembly of sample

Mechanical joints are to be assembled with pipes matching the design pipe diameter of joints as an assembly for the test. Where the material of pipe may affect the performance of mechanical joint, then the selection of assembly is to take into consideration the material of pipe. Unless otherwise specially stated, the length of pipes connected by test joints is to be at least five times the pipe diameter. Verify the design requirements are met before joint assembling. In any case, joints can only be assembled according to the instructions of the manufacturer. Unless otherwise specially stated by the manufacturer, the joint assembly is not allowed to be adjusted during the test period.

7.4 Acceptable test criterion

Where one assembly of mechanical joint fails all or any of the test items in Table 7.5, two assemblies of mechanical joints with the same dimensions and specification as the failed mechanical joints are to be tested. Only the test items in which the assembly of mechanical joint fails at the first time are to be re-tested. Where there is still one assembly failing the test, then the assemblies of such dimensions and specification are considered as disqualified.

The method and result of each test are to be recorded and available when necessary.

7.5 Type test items

- (1) See Table 7.5 for type test items.
- (2) Applicable test items may be selected according to the service condition of mechanical joints. For the test items which are not carried out, CCS will limit their uses in the approval certificate.
- (3) The mechanical joints applicable to the system with pulse pressure (excluding water hammer) must be subjected to the pressure pulsation test.
- (4) The bilge system used in machinery spaces and dangerous spaces of high fire risk (e.g. cargo pump room and vehicle) and slip-on joints with requirements on fire endurance in Table 2.5.3.1(2) of Chapter 2, Part Three of CCS Rules must be subjected to the fire test. The compression couplings containing components which are easily damaged by fire must also be subjected to the fire test.
- (5) The mechanical joints applicable to suction line must be subjected to the vacuum test.
- (6) Raw materials which are not approved by CCS may be required by CCS to partially undergo material retest, non-destructive inspection of weld seam and overall dimension inspection according to the scope of products and the quality control condition of the manufacturer.
- (7) Verification test may be required to be performed by CCS according to maximum axial, radial and angular deviations allowed by the manufacturer.

Test Procedures of mechanical joints

Table 7.5

Tests		Types of mechanical joints		
		Compression coupling Pipe joint	Slip-on joints	
			Grip type machined grooved type	Slip type
1	Tightness test	×	×	×
2	Vibration (fatigue) test	×	×	-
3	Pressure pulsation test ^①	×	×	-
4	Burst pressure test	×	×	×
5	Pull-out test	×	×	-
6	Fire test	×	×	×
7	Vacuum test	× ^③	×	×
8	Repeated assembly test	× ^②	×	-

Abbreviations: × test is required - test is not required

Note: ①For use in those systems where pressure pulsation other than water hammer is expected.

②Except press type.

③Except joints with metal-to-metal tightening surface.

7.6 Test methods

7.6.1 Tightness test

All mechanical joints are to be subjected to the following tightness tests to ensure correct assembly and tightness of joints:

- (1) Connect the test sample of assembly of mechanical joint to the pipe or pipeline, pour into test liquid and evacuate the air inside the pipe according to this Guideline and the instructions of the manufacturer.
- (2) The assembly of mechanical joint to be used for rigid connection is not to be subjected to vertical restraint.

- (3) The internal pressure of joint assembly is to be gradually increased to 1.5 times design pressure and maintained for at least five minutes under the test pressure. Where there is a pressure drop or visible liquid leakage, the test (including fire test) is to be repeated on two samples. If during the repeated test one sample still fails, the joints are to be regarded as disqualified in the test.
- (4) Other types of tightness test, e.g. air tightness test, may be acceptable.
- (5) For compression couplings, the static gas tightness test is to be carried out under the condition of gaseous medium so as to verify the integrity and tightness of the assembly of mechanical joint. The test pressure is to be raised to the highest pressure or 7.0 MPa, whichever is lower.
- (6) Where the gaseous medium permitted in (1) described above is used in the tightness test, the static pressure test in (2) described above is not necessary to be repeated.

7.6.2 Vibration (fatigue) test

As the vibration under the working condition may cause fatigue, the assembly of mechanical joint is to be subjected to the following vibration tests for the purpose of determining its ability to resist fatigue. The results of vibration tests are to indicate no leakage or damage which is may cause failure.

(1) Test of compression and pipeline joints

- ① Compression couplings, pipeline joints or other similar joints to be used for rigid connection of pipeline are to be tested according to the following methods. Rigid connection means the connection of pipe sections without free angular and axial movements.
- ② For two pipe sections connected by the test joint, rigidly fix one end of the pipe section, and fit the other end to a vibration source. The test device and the assembly of joint to be tested are as shown in Fig. 7.6.2(1).

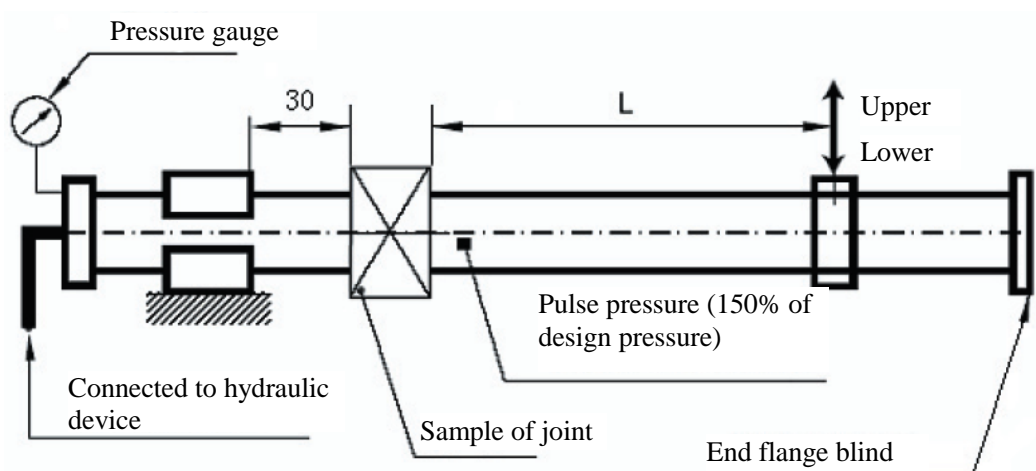

Fig. 7.6.2 (1) Diagram of vibration (fatigue) test device

Fill the joint assembly with test liquid. Evacuate the air and raise the pressure to the design pressure of joints. The pressure during the test period is to be indicated. Where there is a pressure drop or visible indication of leakage, the test is to be repeated according to the requirements of 7.4.

Visual inspection is to be made on the joint assembly in order to find the damage which is the root cause of leakage. Retightening is acceptable within the first 1,000 cycles.

The amplitude of vibration is to be within the range of 5% of that obtained from the following formula.

$$A = \frac{2SL^2}{3ED}$$

Where: A — single amplitude, in mm;

L — length of pipe section, in mm;

S — permissible bending stress (based on 0.25 of yield stress), in N/mm²;

E — elastic modulus of pipe material (for carbon steel, E = 210 kN/mm²);

D — outside diameter of pipe, in mm.

The test sample is to undergo 10⁷ cycles with vibration frequency not less than 20 ~ 50 Hz without leakage or damage.

(2) Grip type and machined grooved type joints

① Grip type joints and other similar joints with elastic elements are to be tested according to the following methods.

② The cantilever-type test device may be used for fatigue strength test of components. The test sample is to be arranged as shown in Fig. 7.6.2(2).

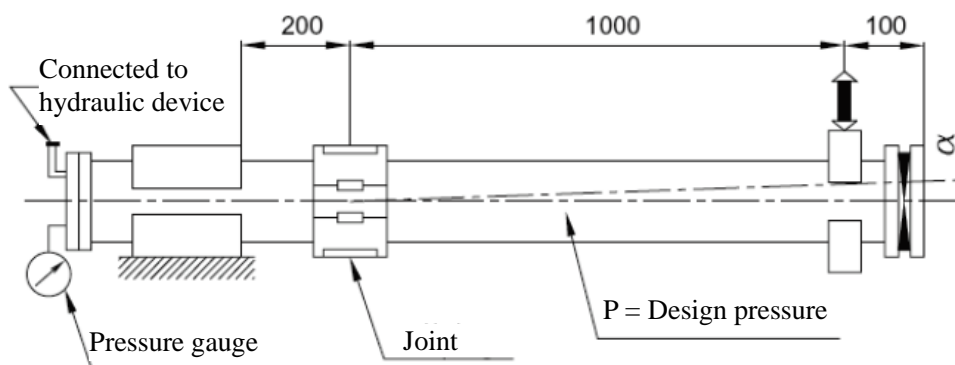

Fig. 7.6.2 (2) Diagram of vibration (fatigue) test device

Connect two pipe sections together through test joints. Rigidly fix one end of the pipe section, and fit vibration source to the other end. The pipe section connected to the fixed end is to be short as much as possible, and in any case is not to exceed 200 mm. The assembly of mechanical joint is not to be subjected to vertical restraint. Fill the assembly with test liquid. Remove the air and make the pressure rise to the design pressure of joints. The initial deviation angle in the axial direction of the pipe is to be equal to the maximum deviation angle recommended by the manufacturer. The amplitude is to be measured at the place 1 m away from the central line of the joint assembly to the free pipe end connecting the rotating components of the device (as shown in Fig. 7.6.2(2)).

What is described in the following table is parameter for the test on the same assembly:

Test parameter

Table 7.6.2

Number of cycles	Amplitude, mm	Frequency, Hz
3×10^6	± 0.06	100
3×10^6	± 0.5	45
3×10^6	± 1.5	10

The pressure during the test period is to be shown. Where there is a drop in pressure or there is visual indication of leakage, the test is to be repeated according to the requirements of 7.4. Visual inspection is to be made on the joint assembly in order to find the final cause of the leakage.

7.6.3 Pressure pulsation test

The assembly of mechanical joint to be used for rigid pipeline connection is to be tested according to the following methods for the purpose of determining its ability to bear the pressure pulsation under the working condition.

The sample of mechanical connection for this test may be the one used in the tightness test provided that the sample has passed the tightness test.

For the pressure and pipeline joints, the vibration test and the pressure pulsation test are to be carried out at the same time.

The test sample of mechanical joints is to be connected to the pressure source capable of producing pressure pulsation as shown in Fig. 7.6.3. The pressure pulsation is to rise from 0 to 1.5 times the design pressure of joints with frequency of 30 ~ 100 cycles/min. The number of cycles is not to be less than 5×10^5 .

Visual inspection is to be made on mechanical joints for leakage and indication of damage.

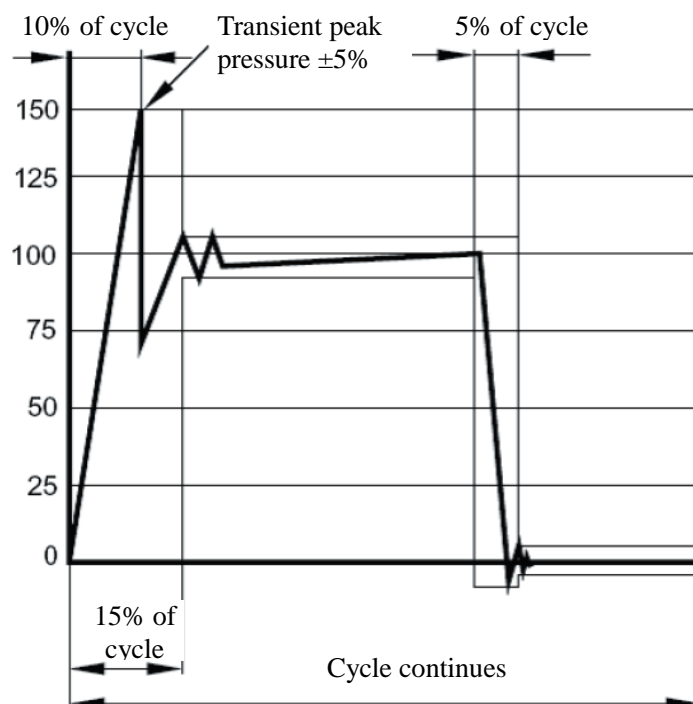

Fig. 7.6.3 Diagram of pressure pulsation

7.6.4 Burst pressure test

The following burst tests are to be carried out for the purpose of determining the ability of the assembly of mechanical joint to bear 4 times the burst pressure.

Connect the test sample of mechanical joints to the pipe or pipe section, pour into test liquid and remove the air. Make the pressure rise to the test pressure with an increase of 10% of the test pressure every one minute. The assembly of mechanical joint to be used for rigid connection is not to be subjected to vertical restraint.

The test is to last at least 5 min under the test pressure.

The test sample of mechanical joints for the tightness test may be used in the burst test provided that it has passed the tightness test.

The sample may be allowed to have slight deformation under the test pressure but not leakage or visible cracks.

7.6.5 Pull-out test

The following pull-out tests are to be carried out for the purpose of determining the ability of the assembly of mechanical joint to bear the axial load causing the pipes breaking away under the working condition.

Fit pipe sections of appropriate sizes to both ends of the assembly of mechanical joint and make the pressure of the test sample rise to the design pressure so that the applied axial load reaches the value obtained from the following formula.

$$L = \frac{\pi}{4} D^2 p$$

Where: D — outside diameter of pipe, in mm;

p — design pressure, in N/mm²;

L — applied actual axial load, in N.

The axial load is to last 5 min.

The pressure during the test period is to be shown. The relative movement between the joint assembly and the pipe is to be measured.

Visual inspection is to be made to confirm whether there is a drop in pressure or there is visual indication of leakage or damage on the assembly of mechanical joint.

No movement is to be allowed of the assembly of mechanical joint in relation to the connecting pipe.

7.6.6 Fire test

The fire test is to be carried out for the purpose of determining the ability of mechanical joints to bear the effect of fire disaster under the working condition. The fire test is to be conducted with the test sample selected in the following standards.

(1) ISO 19921: 2005(E): *Ships and marine technology—Fire Test of Metallic Pipe Components with Resilient and Elastomeric Seals — Test Methods*

(2) ISO 19922: 2005(E): *Ships and Marine Technology—Fire Test of Metallic Pipe Components with Resilient and Elastomeric Seals — Requirements Imposed on the Test Bench*

Instructions on the requirements of standards:

- (1) Where the fire test is to be carried out with circulating water with pressure different from the design pressure of joints (but not less than 0.5 MPa), then the sustained pressure test with pressure two times the design pressure is to be performed.
- (2) A sample with typical drift diameter may be selected for the test in order to assess the fire endurance of mechanical joints of the same design. Where a mechanical joint with drift diameter of D_n is so tested, then the mechanical joints with drift diameter between D_n and $2 D_n$ (both inclusive) are also considered acceptable.

7.6.7 Vacuum test

The following vacuum tests are to be carried out for the purpose of determining the ability of the assembly of mechanical joint to bear the internal pressure which is less than the atmospheric pressure under the working condition.

The assembly of mechanical joint is to be connected to a vacuum pump and to bear absolute pressure of 0.0170 MPa. After the pressure keeps stable, the test sample of the assembly of mechanical joint in the test is to be separate from the vacuum pump and to last 5 min with the pressure unchanged.

The pressure during the test period is to be shown. The internal pressure during the test period is not allowed to rise.

7.6.8 Repeated assembly test

The test sample of mechanical joints is to be dismantled and re-assembled for 10 times according to the instructions of the manufacturer before the tightness test is carried out.

8 Unit/batch inspection

8.1 The mechanical joints for piping system approved by CCS must be subjected to the following tests in order to obtain the product certificate from CCS:

- (1) Verification of material certificate (or re-test);
- (2) Non-destructive test (where applicable);
- (3) Tightness test;
- (4) Appearance quality inspection.

Note: The products for tightness test may be sampled according to relevant requirements of product standards. At least one product of each specification and each batch is generally sampled.

8.2 Records or reports submitted by the manufacturer are to include:

- (1) Quality certificate of plant (where applicable);
- (2) Process inspection record;
- (3) A list of test equipment and inspection equipment used.