



GUIDANCE NOTES
GD 13-2007

CHINA CLASSIFICATION SOCIETY

**GUIDELINES FOR SURVEY OF
WING-IN-GROUND (WIG) CRAFT**

2008

BeiJing

CONTENTS

CHAPTER 1 GENERAL.....	1
Section 1 GENERAL PROVISIONS.....	1
Section 2 SURVEYS AND CERTIFICATES.....	3
CHAPTER 2 STRUCTURES.....	9
Section 1 GENERAL PROVISIONS.....	9
Section 2 STRUCTURAL STRENGTH.....	9
Section 3 HULL OPENING AND TIGHTNESS TEST.....	14
CHAPTER 3 ANCHORING, TOWING, SECURING AND LANDING EQUIPMENT.....	15
Section 1 ANCHORING EQUIPMENT.....	15
Section 2 TOWING EQUIPMENT.....	15
Section 3 SECURING EQUIPMENT.....	16
Section 4 LANDING EQUIPMENT.....	16
CHAPTER 4 MACHINERY AND AUXILIARY SYSTEMS.....	17
Section 1 GENERAL PROVISIONS.....	17
Section 2 POWER UNIT.....	17
Section 3 FUEL OIL SYSTEM.....	18
Section 4 LUBRICATING OIL SYSTEM.....	19
Section 5 AIR INTAKE SYSTEM.....	20
Section 6 EXHAUST SYSTEM.....	20
Section 7 COOLING SYSTEM.....	20
Section 8 VENTILATION SYSTEM IN ENGINE ROOM.....	21
Section 9 BILGE DRAINAGE SYSTEM.....	21
CHAPTER 5 ELECTRICAL INSTALLATIONS.....	22
Section 1 GENERAL PROVISIONS.....	22
Section 2 DISTRIBUTION SYSTEM.....	22
Section 3 ELECTRICAL POWER.....	23
Section 4 CABLES.....	25
Section 5 LIGHTING.....	25
Section 6 LIGHTENING ARRESTING.....	25
CHAPTER 6 MATERIALS AND BUILDING TECHNIQUE.....	26
Section 1 GENERAL PROVISIONS.....	26
Section 2 ADDITIONAL REQUIREMENTS FOR RIVETING.....	26
Section 3 QUALITY INSPECTION.....	28

CHAPTER 1 GENERAL

Section 1 GENERAL PROVISIONS

1.1.1 Application

1.1.1.1 The Guidelines apply to civil wing-in-ground (WIG) craft. For WIG craft engaged on international voyages, the relevant provisions of the Administration and of IMO are to be complied with in addition to those of the Guidelines.^①

1.1.1.2 The Guidelines apply to WIG craft carrying passengers or cargoes (general cargoes), navigating by day within following service weather restriction and not more than 2h or 200 n mile from a place of refuge (whichever is the lesser):

- (1) Service weather restriction I means significant wave height not more than 3 m and scale of wind force not more than 7 (Beaufort scale) in the restricted navigation area;
- (2) Service weather restriction II means significant wave height not more than 2 m and scale of wind force not more than 6 (Beaufort scale) in the restricted navigation area;
- (3) Service weather restriction III means significant wave height not more than 1 m and scale of wind force not more than 5 (Beaufort scale) in the restricted navigation area;
- (4) Service weather restriction IV means significant wave height not more than 0.5 m and scale of wind force not more than 4 (Beaufort scale) in the restricted navigation area.

1.1.1.3 The Guidelines do not apply to following WIG craft:

- (1) WIG craft not engaged in trade;
- (2) WIG craft for sports purpose.

1.1.1.4 The existing craft after repair, alteration or modification are at least to be in compliance with the applicable requirements of the original corresponding Guidelines. Where major repair, alteration or modification is made, such craft are to comply with the requirements of the Guidelines in so far as reasonable and practicable.

1.1.1.5 The stability, fire safety, life-saving appliances and communications, etc. of craft are to comply with the requirements of the flag State Administration relating to safety equipment and environmental protection.

1.1.2 Equivalent and exemption

1.1.2.1 Any craft which embodies structure and features of a novel type may be exempted from any requirement of the Guidelines if the application of which might seriously impede the incorporation of its features or its service, subject to agreement by CCS.

1.1.2.2 Any fitting, material, appliance or apparatus, other than that required in the Guidelines, may be allowed to be fitted in a craft, if it is satisfied by trial thereof or otherwise that such fitting, material, appliance or apparatus is at least as effective as that required in the Guidelines.

1.1.2.3 Equivalence or substitution to those methods of calculation, criteria of evaluation, manufacturing procedures, materials, survey and test requirements specified by the Guidelines may be accepted subject to agreement by CCS, when relevant tests, theoretical basis or service experience are provided, or recognized effective standards are available.

1.1.3 Statutory surveys

1.1.3.1 CCS will undertake part or entire statutory surveys of craft under the authority of the Government of flag State and in accordance with the application or contracts/agreements from the craft owners or designers or manufacturers.

① Refer to IMO MSC/Circ.1054 – Interim Guidelines for Wing-in-ground Craft.

1.1.3.2 For craft intended to be classed with CCS, CCS will carry out the classification survey in conjunction with the statutory survey.

1.1.3.3 CCS will issue relevant statutory certificates and/or reports, upon completion of plan approval, initial survey and survey after construction, and the craft is confirmed satisfying the corresponding statutory requirements.

1.1.3.4 For craft which the classification and statutory surveys are carried out by CCS, where the classification certificate is invalid and affects the condition of survey for issuing relevant statutory certificates, then the corresponding statutory certificates will be invalid simultaneously.

1.1.3.5 Statutory surveys are based on relevant statutory provisions of the flag State Government.

1.1.4 Definitions

1.1.4.1 Unless expressly provided otherwise, for the purpose of the Guidelines:

(1) WIG craft is a multimodal craft which, in its main operational mode, flies by using ground effect above the water or some other surface, without constant contact with such a surface and supported in the air, mainly, by an aerodynamic lift generated on a wing (wings), hull, or their parts, which are intended to utilize the ground effect action.

(2) Ground effect is a phenomenon of increase of a lift force and reduction of inductive resistance of a wing approaching a surface. The extent of this phenomenon depends on the design of the craft and the distance between wing and surface but generally occurs at an altitude less than the mean chord length of the wing.

(3) Zone of the ground effect is the space with ground effect.

(4) Dynamic air cushion means a high pressure region originating between the airfoil and a water surface or some other surface as the airfoil moves within the zone of the aerodynamic effect of this surface.

(5) Static air cushion means a high-pressure region generated by directing air from the propulsion engine or other engine underneath the craft's body and/or wings.

(6) Wing means a profiled plate or three dimensional construction at which aerodynamic or hydrodynamic lift is generated when the craft is under way.

(7) Flap means an element formed as integrated part of, or an extension of, a wing, used to adjust the hydrodynamic or aerodynamic lift of the wing.

(8) Skeg is a vertical or inclined profiled plate or a volumetric construction, which forms part of or is attached to a wing for the purpose of decreasing the inductive aerodynamic resistance or increasing the effectiveness of static or dynamic air cushions.

(9) WIG craft of type A means a craft which is certified for operation only in ground effect.

(10) WIG craft of type B means a craft which is certified to temporarily increase its altitude to a limited height outside the influence of ground effect but not exceeding 150 m above the surface.

(11) Passenger craft is a craft which carries more than twelve passengers.

(12) Displacement mode means the regime, whether at rest or in motion, where the weight of the craft is fully or predominantly supported by hydrostatic forces.

(13) Planing mode denotes the mode of steady state operation of a craft on water surface by which the craft's weight is supported mainly by hydro-dynamic forces.

(14) Transitional mode denotes the transient mode from the displacement mode to the planing mode and vice versa.

(15) Ground effect mode is the main steady state operational mode of flying the WIG craft in ground effect.

(16) Take off/landing mode denotes the transient mode from the planing mode to the ground effect mode and vice versa.

(17) Fly-over mode denotes increase of the flying altitude for WIG craft of type B within a limited period, which exceeds the vertical extent of the ground effect but does not exceed 150 m.

(18) Design waterline means the waterline corresponding to the full-load displacement of the craft with no lift or propulsion machinery active.

(19) Full-load displacement (t) means the weight of sea water displaced by a craft under an immediate sailing condition with the required equipment, cargo stores, accessories, rigging, crew, etc., 100% of fuel oil, lubricating oil, fresh water, food, supplies and rated passengers onboard the craft.

(20) Length means the overall length of the underwater watertight envelope of the rigid hull, excluding appendages, at or below the design waterline in the displacement mode with no lift or propulsion machinery active.

(21) Place of refuge is any naturally or artificially sheltered area which may be used as a shelter by a craft under heavy weather conditions likely to endanger its safety.

Section 2 SURVEYS AND CERTIFICATES

1.2.1 Types of survey

1.2.1.1 The types of survey are divided into:

(1) Initial survey, including:

- ① construction survey for newbuildings;
- ② initial survey for existing craft (including those constructed not under the design review and supervision of CCS in accordance with the Guidelines, however subsequent survey carried out and considered to comply with the provisions of the Guidelines by CCS).

(2) Surveys after construction, including:

- ① annual survey;
- ② special survey;
- ③ occasional survey.

1.2.1.2 All surveys mentioned in this Section may be carried out as appropriate basing on each type of craft.

1.2.2 Issue of certificates

1.2.2.1 Where a craft is found in compliance with the relevant provisions of the Guidelines and other requirements after the initial classification survey, the character of classification and corresponding class notations will be assigned and the classification certificate will be issued.

1.2.2.2 The validity of classification certificates is not to exceed 5 years.

1.2.3 Interval of surveys after construction

1.2.3.1 The craft having the classification certificate is to be carried out surveys after construction in accordance with the specified interval and the requirements of 1.2.6 to 1.2.7 of this Section.

1.2.3.2 Annual surveys are to be completed within 3 months before or after each anniversary date of the certificate. After a satisfactory survey, the Surveyor is to endorse the corresponding certificates to confirm the certificates are valid continuously within the specified period.

1.2.3.3 The interval of special surveys is not to exceed 5 years. Corresponding certificate is to be renewed after a satisfactory survey. Where it is not able to complete the special survey by its due date, the craft may be granted an extension not exceeding 3 months subject to agreement.

1.2.3.4 An occasional survey is to be applied for in either of the following conditions:

- (1) an accident to a craft which affects its seaworthiness;
- (2) alteration of a craft's intended purpose or service area as restricted in its certificates;
- (3) invalidity of a craft's statutory certificate;
- (4) changes of a craft's owner or manager, and of a craft's name or port of registry;
- (5) repairs or modification involved in the safety of a craft.

After a satisfactory survey, the Surveyor is to endorse the corresponding certificates to confirm the certificates are valid continuously within the specified period.

1.2.3.5 All the certificates will be invalid automatically where the craft is not operated in accordance with the service requirements stipulated by the certificates or is not carried out surveys after construction.

1.2.4 Characters of classification and class notations for classed craft

1.2.4.1 Craft applied for and classed with CCS is to be assigned with the following characters of classification as appropriate after approval:

(1) For craft engaged on international voyages:

- ★ CSA
- ★ CSM or
- ★ CSA
- ★ CSM or
- ★ CSA
- ★ CSM

(2) For craft engaged on domestic voyages:

- ★ CSAD
- ★ CSMD or
- ★ CSAD
- ★ CSMD or
- ★ CSAD
- ★ CSMD

The meanings of the characters of classification are:

★ CSA—indicating that the structure and equipment of the craft have been constructed with plan approval by and under the supervision of CCS, and found to be in full compliance with the Guidelines;

★ CSA—indicating that the structure and equipment of the craft have not been constructed with plan approval by and under the supervision of CCS, but they have been found after classification survey by CCS to be in compliance with the Guidelines;

★ CSM—indicating that the product surveys for craft's propulsion and essential auxiliary machinery have been carried out by CCS, the craft's machinery and electrical installations have been constructed with plan approval by and under the supervision of CCS, and found to be in compliance with the Guidelines;

★ CSM—indicating that the product surveys for craft's propulsion and essential auxiliary machinery have not been carried out by CCS, but the craft's machinery and electrical installations have been constructed with plan approval by and under the supervision of CCS, and found to be in compliance with the Guidelines;

★ CSM—indicating that the craft's machinery and electrical installations have not been constructed with plan approval by and under the supervision of CCS, but they have been found after classification survey by CCS to be in compliance with the Guidelines;

★ CSAD—indicating that the structure and equipment of the craft have been constructed with plan approval by and under the supervision of CCS, and found to be in full compliance with the Guidelines;

★ CSAD—indicating that the structure and equipment of the craft have not been constructed with plan approval by and under the supervision of CCS, but they have been found after classification survey by CCS to be in compliance with the Guidelines;

★ CSMD—indicating that the product surveys for craft’s propulsion and essential auxiliary machinery have been carried out by CCS, the craft’s machinery and electrical installations have been constructed with plan approval by and under the supervision of CCS, and found to be in compliance with the Guidelines;

★ CSMD—indicating that the product surveys for craft’s propulsion and essential auxiliary machinery have not been carried out by CCS, but the craft’s machinery and electrical installations have been constructed with plan approval by and under the supervision of CCS, and found to be in compliance with the Guidelines;

★ CSMD—indicating that the craft’s machinery and electrical installations have not been constructed with plan approval by and under the supervision of CCS, but they have been found after classification survey by CCS to be in compliance with the Guidelines.

1.2.4.2 Craft classed with CCS will be assigned type notations and service restriction notations to be affixed to the character of classification, depending on the specific cases.

(1) Craft type notations are shown in Table 1.2.4.2(1).

(2) Service restriction notations are shown in Table 1.2.4.2(2).

Type notations **Table 1.2.4.2(1)**

Type of craft	Type notation
WIG craft of type A	WING IN GROUND CRAFT A
WIG craft of type B	WING IN GROUND CRAFT B

Service restriction notations **Table 1.2.4.2(2)**

Service restriction	Service restriction notation
Service weather restriction I	Weather Restriction I, $h_{1/3}(X)$ ^①
Service weather restriction II	Weather Restriction II, $h_{1/3}(X)$
Service weather restriction III	Weather Restriction III, $h_{1/3}(X)$
Service weather restriction IV	Weather Restriction IV, $h_{1/3}(X)$

1.2.4.3 If planned maintenance system approved by CCS is carried out to the engine and complies with the provisions of the relevant rules of CCS, machinery notation specified in Table 1.2.4.3 may be affixed to the character of classification.

Machinery notation **Table 1.2.4.3**

Name	Machinery notation
Machinery planned maintenance system	PMS (Planned Maintenance System)

1.2.4.4 Planned maintenance system approved by CCS may replace the corresponding special survey items stipulated in this Chapter.

1.2.5 Initial survey

1.2.5.1 Before construction of a craft, plans and documents in triplicate as specified in 1.2.5.3 and 1.2.5.4 below are to be submitted to CCS for approval.

1.2.5.2 The approved plans and documents are only effective in the designated scope of the construction numbers. The validity of the approved plans and documents is 4 years.

① $h_{1/3}(X)$ is design significant wave height, in m, indicating that the craft can only operate under this wave height(X).

1.2.5.3 The following plans and documents are to be submitted to CCS for approval as appropriate:

- * (1) General arrangement;
- (2) Calculations of aerodynamic load;
- (3) Calculations of hydrodynamic load;
- (4) Calculations of hull girder strength and local strength (including main wing);
- * (5) Construction profile of hull (including main transverse sections);
- * (6) Construction profile of main wing;
- * (7) Connection plan of hull and main wing;
- * (8) Construction plan of vertical and horizontal tail and skeg;
- * (9) Structure and arrangement of doors, windows and covers;
- (10) Laminate design;
- (11) Shell expansion;
- (12) Calculations of equipment number;
- (13) Arrangement of anchoring, securing and towing equipment;
- (14) Connection plan of seats and deck;
- (15) Anti-corrosion design of hull structure (including wing structure);
- (16) Test and sea trial program;
- (17) Technology specifications of construction;
- (18) Construction plan of engine supporting frame;
- (19) Arrangement and construction plan of landing equipment;
- * (20) Strength calculations of main components of landing equipment;
- (21) Arrangement for operations of water rudder, air rudder, wing and flap;
- * (22) Strength calculations of air rudder and main control components of wing;
- * (23) Arrangement of power unit;
- * (24) Plan of fuel oil system (including structure, material, installation and venting of oil tank);
- (25) Plan of exhaust system (including material of exhaust pipe);
- * (26) Plan of hydraulic pressure system;
- (27) Plan of lubricating oil system;
- (28) Plan of cooling system;
- (29) Plan of bilge discharge system (if any);
- (30) Plan of engine room ventilation system (if any);
- * (31) Propeller plan and calculations of blade strength;
- * (32) Calculations of shafting strength and arrangement of shafting (if any);
- (33) Calculations of torsional vibration of shafting (if any);
- (34) Calculations of whirling vibration of shafting (if any);
- (35) Calculations of axial vibration of shafting (if any);
- (36) Calculations of electric loading analysis;
- * (37) Plan of electric power system (including primary system and secondary system);
- (38) Schematic diagrams of lighting (including navigation light and signal light system);
- (39) Arrangement of electrical installations;
- (40) Planned maintenance system.

1.2.5.4 The following plans and documents are to be submitted to CCS for information as appropriate:

- (1) Hull specification;
- (2) Machinery specification;

- (3) Electrical specification;
- (4) Lines of hull, main wing, tail, oblique wing and skeg;
- (5) Calculations of weight and gravity center;
- (6) Calculations of hull vibration.

1.2.5.5 The names of plans and documents to be submitted may not be all the same, however at least the contents of the above-mentioned plans and documents are to be included. In addition to 1.2.5.3 and 1.2.5.4, other plans and documents are to be submitted as may be required by CCS.

1.2.5.6 Hull surveys of newbuildings are as follows:

- (1) to confirm the marine product certificate and technology approval of raw material used for hull and wing structure. For products not for marine use, the manufacturers are to provide quality guarantee and carry out chemical composition and physical properties tests according to the provisions. Main raw material of fiber-reinforced plastic WIG craft is to be manufactured by the approved manufacturer;
- (2) for fiber-reinforced plastic WIG craft, to examine forming die and mechanical properties report of specimen;
- (3) hull assembly and riveting survey;
- (4) to examine structure tightness;
- (5) to examine fire structure;
- (6) to examine hull structure and main control system accessories;
- (7) tightness test to hull, wing, tail and skeg (including doors, windows and covers);
- (8) seakeeping test to lead craft;
- (9) rigidity test to lead craft (if necessary);
- (10) vibration and ground test to lead craft;
- (11) measurement for whole weight and gravity center of craft;
- (12) survey of anchoring, towing, securing and landing equipment.

1.2.5.7 Machinery surveys and electrical surveys of newbuildings are as follows:

- (1) to examine qualification certificates of marine product and aviation product and their period of validity;
- (2) to examine fuel oil system, lubricating oil system, cooling system, ventilation system, exhaust system and bilge discharge system;
- (3) to examine control system;
- (4) to examine hydraulic system;
- (5) test of mechanical equipment after installation;
- (6) to examine laying condition of cable;
- (7) to examine reliability of earthing technology;
- (8) test of electrical equipment after installation.

1.2.5.8 The plans and documents of the existing craft for initial survey may be in accordance with the requirements marked with * in 1.2.5.3. The initial survey items may be determined depending on the craft's age and actual condition, but to be carried out at least in accordance with the annual survey items. For passenger craft over 5 years of age, surveys are to be carried out in accordance with the special survey items.

1.2.6 Annual survey

1.2.6.1 Annual surveys are as follows:

- (1) to examine damage or crack of the structure (such as hull, wing and skeg), especially the structure at the corner of door and window frame and the integrity of the envelop at upper part of hull;

- (2) hose test onshore to structures, such as hull (including parts below design waterline), main wing and skeg, which require watertightness or weathertightness, to examine the integrity of tightness of structures providing buoyancy and reserve buoyancy. The test requirements are in accordance with Chapter 2;
- (3) to examine any evidence of loosing or water leakage in way of connections of hull and wing as well as tail and skeg;
- (4) to examine integrity of internal structure;
- (5) to examine integrity of internal corridor and seats;
- (6) to examine direction and attitude control system (including water rudder and air rudder, wing control system);
- (7) to examine integrity of anchoring, securing and towing equipment;
- (8) to examine any alteration to installations and arrangement for structural fire protection;
- (9) to examine whether all fire-fighting equipments are complete and under effective working condition;
- (10) to examine all sea openings together with valves, cocks and fastenings connecting hull;
- (11) visual inspection to propeller blade and shafting to find whether there are abnormal conditions such as crack and ensure normal operation;
- (12) visual inspection to oil tanks to find whether there is damage to tank configuration and whether the connection of accessory and tank as well as tank and hull is in good condition;
- (13) visual inspection to fuel oil system, lubricating oil system, cooling system, exhaust system and hydraulic system to ensure they are in good condition;
- (14) to examine function of fuel oil and lubricating oil cutting equipment;
- (15) visual inspection to control system to find whether guidance unit, pulley, steel cable joint and adjusting nut are in good condition;
- (16) to examine working condition of machinery equipment and carry out effectiveness test when necessary;
- (17) to examine working condition of electrical equipment and carry out effectiveness test when necessary;
- (18) to examine whether instruments in the navigation bridge are in good condition;
- (19) to examine cables and measure insulation resistance as far as possible;
- (20) to examine effectiveness of earthing measures of the craft.

1.2.7 Special survey

1.2.7.1 In addition to annual survey items, the special survey items are to include the following:

- (1) structural integrity of wave slamming areas of hull and skeg and structure of short space of engine;
- (2) connection of seats to floor;
- (3) effectiveness test is to be carried out to engine and control system (in general, effectiveness test for planing mode, and flight test in special cases);
- (4) effectiveness test is to be carried out to shafting and propeller as well as engine;
- (5) oil tanks are to be subject to tightness test with test pressure of $0.24 \times 10^5 \text{Pa}$ for 2 min without any leakage;
- (6) to check and confirm the protection values set to main engine generator.

1.2.7.2 For fiber-reinforced plastic craft, the laminated plates are not to turn to white or delaminate without any leakage.

1.2.7.3 For aluminum alloy craft navigating at sea, thickness measurements on suspect areas of hull plating are to be carried out at the second and subsequent special surveys.

CHAPTER 2 STRUCTURES

Section 1 GENERAL PROVISIONS

2.1.1 General requirements

2.1.1.1 This Chapter applies to hull, main wing and other important structure of WIG craft, such as vertical and horizontal tail, skeg and landing frame.

2.1.1.2 During structural design, spaces necessary for routine inspection, maintenance and change of parts are to be considered.

Section 2 STRUCTURAL STRENGTH

2.2.1 Definitions

2.2.1.1 Service load is the maximum load which may be undertaken by part of structure under design condition as well as wave height and wind scale condition specified by approved service weather restriction (including taking off and landing).

2.2.1.2 Design load is the load obtained by multiplying service load by safety factor. Safety factor is determined according to reliability level of service load and generally taken as 1.5~2.0.

2.2.2 Hull design load

2.2.2.1 Load condition to be checked is the condition of service load of hull structure subjected to hydrodynamic load when the WIG craft is landing and striking wave. The hydrodynamic load is related to wave height of landing water area, launching speed and diving angle.

Service load of hull structure is to take the value of maximum hydrodynamic load when the hull strikes wave by obverse or side at a possible diving angle and under wave height specified by service weather restriction. The load conditions to be considered are to at least include three conditions of hull symmetrical launching, i.e., symmetrical redan launching, bow symmetrical launching and stern symmetrical launching. Consideration is also to be given where the hydrodynamic load of hull asymmetrical launching is greater than that of symmetrical launching. In addition, if worse load condition will cause maximum load, this load condition is also to be considered.

2.2.2.2 Service loads for hull structure usually use actual data and model test data similar to WIG craft. If such data is absent, hydrodynamic loads of three symmetrical launching conditions to be checked as specified in 2.2.2.1 may be determined according to 2.2.2.3 to 2.2.2.6.

2.2.2.3 In general, maximum hydrodynamic load occurs at symmetrical launching of hull redan. At that time, the hydrodynamic resultant force P_{ZS} acting on the hull may be assumed to be through craft's centre of gravity and may be calculated according to following formula:

$$P_{ZS} = ng\Delta \quad \text{kN}$$

where: Δ — full-load displacement, in t;

g — acceleration of gravity, to be taken as 9.81m/s²;

n — overload coefficient for redan symmetrical launching, to be determined according to 2.2.2.4.

2.2.2.4 Overload coefficient n for hull redan symmetrical launching may be calculated according to following formula:

$$n = \frac{C_1 V_{ZS}^2}{tg^{2/3} \beta \Delta^{1/3}}$$

where: C_1 — coefficient, may be determined according to actual data of sister craft or similar craft.

If such data is absent, C_1 may be taken as follows:

$C_1 = 0.00444$ design significant wave height for cruise flight $h_{1/3} = 2.5\text{m}$

$C_1 = 0.00391$ design significant wave height for cruise flight $h_{1/3} = 2.0\text{m}$

$C_1 = 0.00348$ design significant wave height for cruise flight $h_{1/3} = 1.5\text{m}$

$C_1 = 0.00301$ design significant wave height for cruise flight $h_{1/3} = 1.0\text{m}$;

V_{zs} — flying speed at hull redan symmetrical launching of WIG craft, in m/s;

β — deadrise angle at launching transverse section in way of redan, in o, see Figure 2.2.2.4;

Δ — full load displacement, in t.

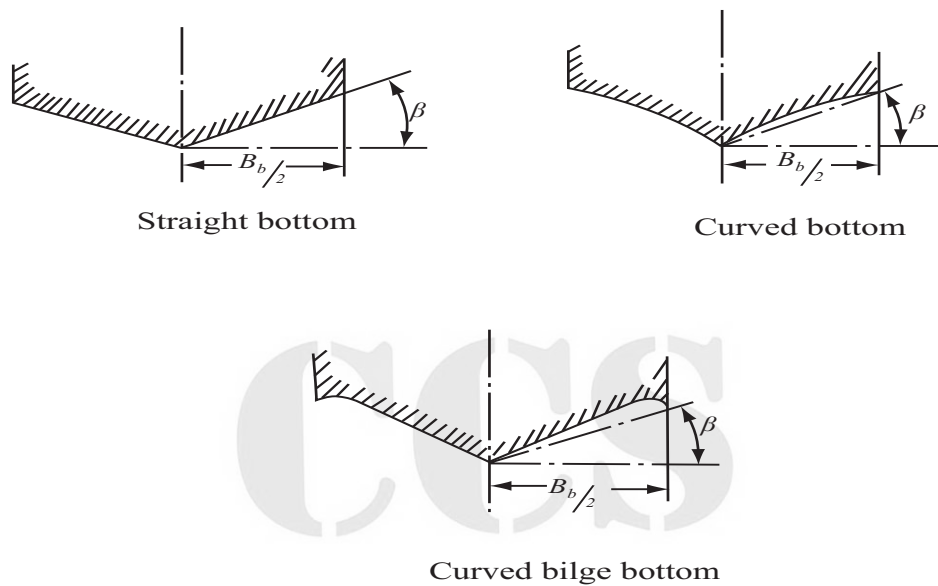

Figure 2.2.2.4

2.2.2.5 The resultant force P_{zs} of hydrodynamic loads of bow or stern launching may be calculated according to following formula:

$$P_{zs} = ng\Delta \quad \text{kN}$$

where: g — acceleration of gravity, to be taken as 9.81m/s^2 ;

n — overload coefficient, may be calculated according to following formula:

$$n = \frac{C_1 V_{zs}^2}{tg^{2/3} \beta \Delta^{1/3}} \times \frac{K_1}{(1+r_x^2)^{2/3}}$$

where: C_1 — coefficient, the same as that in 2.2.2.4;

V_{zs} — flying speed at bow/stern launching, in m/s;

β — deadrise angle of launching transverse section at bow or stern, in o, see Figure 2.2.2.4;

Δ — full load displacement, in t;

r_x — ratio of horizontal distance between center of gravity of craft and launching load acting section to diving inertia radius;

K_1 — longitudinal distribution coefficient of launching overload along hull, may be determined according to actual data of sister craft or similar craft. If such data is absent, K_1 may be taken according to Figure 2.2.2.5. The fore hull length L_f in the Figure is the length from fore end of hull to hull redan near center of gravity, and the aft hull length L_a is the length from the hull redan to small redan at stern.

On determining above-mentioned β , r_x and K_1 , launching transverse section may be assumed that hydrodynamic load P_{zs} at bow launching acts on transverse section in way of 20% L_f from fore end of hull and hydrodynamic load P_{zs} of stern launching acts on transverse section in way of 85% L_a from the hull redan.

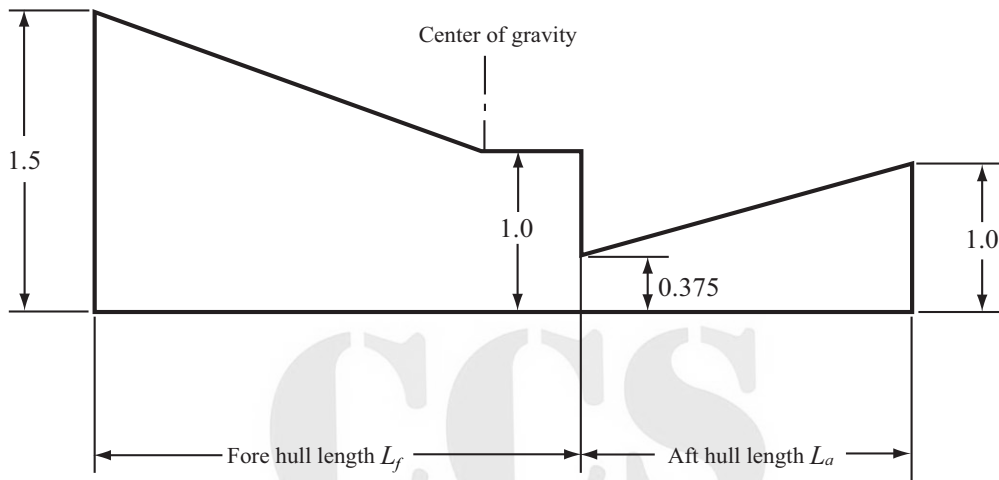

Figure 2.2.2.5 Longitudinal distribution coefficient K_1

2.2.2.6 Whether it is hull redan launching or bow/stern launching, local pressure P_{JB} acting on plate and longitudinal at hull bottom launching area may be calculated according to following formula:

$$P_{JB} = \frac{C_2 K_2 V_{zs}^2}{\text{tg}\beta} \quad \text{kN/m}^2$$

where: C_2 — coefficient, may be determined according to actual data of sister craft or similar craft.

If such data is absent, C_2 may be taken as follows:

$C_2 = 0.0826$ design significant wave height for cruise flight $h_{1/3} = 2.5\text{m}$

$C_2 = 0.0700$ design significant wave height for n cruise flight $h_{1/3} = 2.0\text{m}$

$C_2 = 0.0580$ design significant wave height for cruise flight $h_{1/3} = 1.5\text{m}$

$C_2 = 0.0460$ design significant wave height for cruise flight $h_{1/3} = 1.0\text{m}$;

V_{zs} — flying speed at hull redan symmetrical launching of WIG craft, in m/s;

β — deadrise angle of launching transverse section at bow or stern, in $^\circ$, see Figure 2.2.2.4;

K_2 — longitudinal distribution coefficient of distribution pressure along hull, may be determined according to actual data of sister craft or similar craft. If such data is absent, K_2 may be taken according to Figure 2.2.2.6.

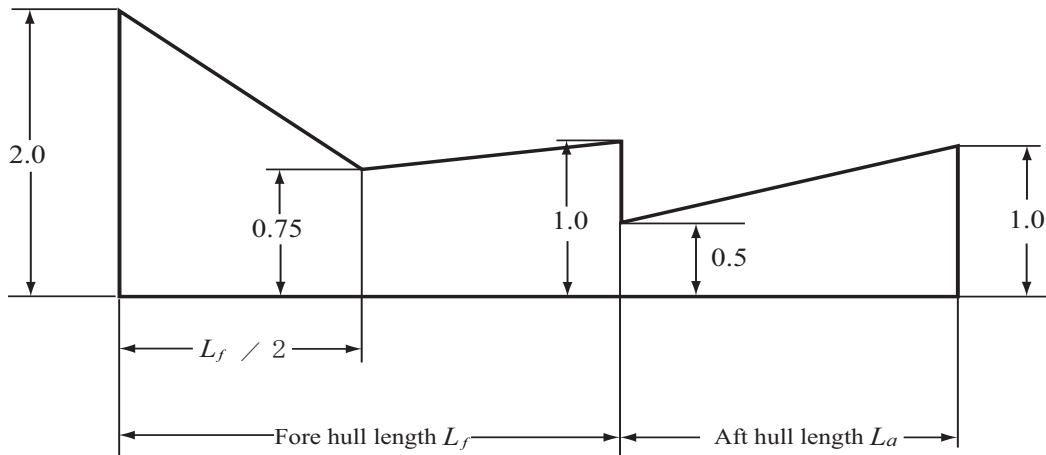

K_2 (bottom pressure)

Figure 2.2.2.6 Longitudinal distribution coefficient K_2

The design pressure of above-mentioned components at hull bottom for local strength check may be obtained by multiplying local pressure acting on bottom plate and longitudinal calculated according to above formula by safety factor.

2.2.2.7 Whether it is hull redan launching or bow/stern launching, distribution pressure P_{FB} acting on keel and frame ring at hull bottom launching area may be calculated according to following formula:

$$P_{FB} = \frac{C_3 K_2 V_{ZS}^2}{\text{tg}\beta} \quad \text{kN/m}^2$$

where: C_3 — coefficient, may be determined according to actual data of sister craft or similar craft.

If such data is absent, C_3 may be taken as follows:

$C_3 = 0.0321$ design significant wave height for cruise flight $h_{1/3} = 2.5\text{m}$

$C_3 = 0.0283$ design significant wave height for n cruise flight $h_{1/3} = 2.0\text{m}$

$C_3 = 0.0252$ design significant wave height for cruise flight $h_{1/3} = 1.5\text{m}$

$C_3 = 0.0218$ design significant wave height for cruise flight $h_{1/3} = 1.0\text{m}$;

V_{ZS}, β and K_2 — the same as those in 2.2.2.6.

The design pressure is obtained by multiplying distribution pressure on keel and frame ring at bottom launching area calculated according to above formula by safety factor.

2.2.2.8 Whether it is redan launching, bow launching or stern launching for WIG craft, bottom launching length l_{ZS} may be calculated according to following formula:

$$l_{ZS} = \frac{P_{ZS}}{P_{JB} B_b} \quad \text{m}$$

where: P_{ZS} — resultant force of hydrodynamic load calculated according to 2.2.2.3 or 2.2.2.5, in kN;

P_{JB} — local pressure of launching area calculated according to 2.2.2.6, in kN/m²;

B_b — bilge mean breadth of bottom launching area, in m, see Figure 2.2.2.4.

2.2.2.9 To obtain hull design load of three conditions by multiplying resultant force of hydrodynamic load of three loading conditions as maximum load by safety factor and distribute it on launching length calculated from 2.2.2.8, thus the hull overall longitudinal bending moment and shearing force corresponding to three hull launching conditions are obtained respectively for check of hull girder strength.

2.2.3 Design load of wing

2.2.3.1 Wings of WIG craft include the structure such as main wing and tail (flat tail and vertical tail) and are mainly subjected to aerodynamic load (including gust load) as well as imbalanced moment, rotating acceleration and inertia force during landing. Aerodynamic load and its distribution are to be determined by wind tunnel model test.

(1) Aerodynamic load of main wing includes aerodynamic force due to change of velocity and main wing attack angle, power augment, flying over condition (if any) and possible horizontal and vertical gust.

(2) Inertia load of main wing mainly checks imbalanced inertia moment due to the difference between the position of center of gravity of wing and the position of center of gravity of whole craft under the condition of bow launching and stern launching.

(3) For main wing and the connection between main wing and hull, bending moment produced by a side skeg striking wave under asymmetrical redan launching condition is also to be considered.

(4) Aerodynamic load of tail is to include three basic conditions of balanced load, maneuvering load and gust load. At the same time, symmetry, asymmetry and possible combined load conditions of flat tail and vertical tail are also to be considered.

(5) Aerodynamic load of flat tail is determined according to balanced load under stabilized maneuvering condition and aerodynamic load augmentation due to vertical gust is additionally checked.

(6) Aerodynamic load of vertical tail is determined according to yaw condition. For WIG craft with multiengine, it is determined according to the requirements of balanced yaw moment when single side engine stops, and aerodynamic load augmentation due to lateral gust is additionally checked.

(7) Inertia loads of flat tail and vertical tail mainly check inertia load due to rotation of tail around the center of gravity of the craft acted by overload at the center of gravity of the craft and imbalanced moment under stern launching.

(8) Structural design load of flap used to control flying attitude of WIG craft is to be determined according to wind tunnel test. If flap touches water during flight, hydrodynamic load is also to be considered.

2.2.4 Design load of other structure

2.2.4.1 For loads undertaken by supporting structure of landing frame (if applicable), the whole craft weight under full load condition is to be considered.

2.2.4.2 For design load of skeg (if applicable) structure, possible maximum service load under symmetrical and asymmetrical launching condition of WIG craft is to be considered.

2.2.4.3 Some structures of the craft subjected to periodical loads will cause fatigue damage, and these periodical loads are to be considered.

2.2.5 Structural strength

2.2.5.1 Girder strength of hull is to be checked according to design load obtained from 2.2.2.9 of this Chapter. At least three transverse sections are to be taken for check.

2.2.5.2 Local strength check is to be carried out to each important part of craft's structure mentioned in 2.1.1.1 of this Chapter. In addition, strength check is to be carried out to the connection between hull and main wing and the connection between skeg and main wing.

2.2.5.3 It is to be ensured that structural components will not be damaged or produce to lose global stability under the action of design load. Under the action of service load, structural components will not lose local stability and cause permanent deformation.

2.2.5.4 Strength check is also to be carried out to connecting pieces for hull structure (such as rivet and screw).

2.2.5.5 Fatigue strength is to be checked to structural components subjected to periodical loads, if necessary.

2.2.5.6 The structure of WIG craft is not to cause harmful or excessive vibration.

2.2.6 Verification

2.2.6.1 The lead craft of the same type are to pass seakeeping test to verify whether the structural strength, design load and safety factor of WIG craft are reasonable. The flight speed under the worst launching condition and maximum significant wave height verified by test are to be recorded in operation manual of the craft.

Section 3 HULL OPENING AND TIGHTNESS TEST

2.3.1 Hull tightness and opening

2.3.1.1 The hull structure below flooding point in intact stability calculation and skeg are to be kept watertight. The opening of landing frame retractable equipment (if any) on hull structure are to be kept watertight.

2.3.1.2 The hull structure above flooding point (including main wing and tail) are to be kept weathertight. Each weather opening on hull and wing, including external doors, windows and hole covers, is to be kept weathertight. The strength of these door, window and cover are to be equivalent to that of hull structure connected with them.

2.3.2 Tightness test

2.3.2.1 After completion of hull, hose testing is to be carried out to each exposed part of hull required to be watertight and weathertight as well as watertight transverse bulkhead to verify structural tightness. The test is to be carried out at the final stage of outfitting.

2.3.2.2 The requirements to hose testing are that the minimum pressure in the hose, at least equal to 0.2 MPa, is to be applied at a maximum distance of 1.5 m, the nozzle inside diameter is not to be less than 12 mm and the moving speed of water column is not to be more than 0.1 m/s.

2.3.2.3 When hose test cannot be performed without damaging possible machinery, electrical installations, insulation or outfitting already installed, it may be replaced by a careful visual inspection of all the crossings and welded joints, where necessary, dye penetrant test or ultrasonic leak test may be required.

CHAPTER 3 ANCHORING, TOWING, SECURING AND LANDING EQUIPMENT

Section 1 ANCHORING EQUIPMENT

3.1.1 General requirements

3.1.1.1 Each WIG craft is to be provided with a positioning anchor, anchor cable/chain and fixing equipment. It may be otherwise considered according to actual condition of craft route and with the consent of CCS.

3.1.2 Allocation requirements

3.1.2.1 In general, a high holding power anchor is to be allocated, and the anchor weight Q is not to less than the value obtained from following formula:

$$Q = 1.3 N \quad \text{kg}$$

where: N is the equipment number and calculated according to following formula:

$$N = \left[\Delta^{\frac{2}{3}} + 2A_1 + 0.1A_2 \right] k$$

where: Δ — full load displacement, in t;

A_1 — transverse projected area above design waterline, in m²;

A_2 — lateral projected area above design waterline, in m²;

k — coefficient, to be taken according to service weather restriction:

$k = 1.2$ for service weather restriction I

$k = 1.0$ for service weather restriction II

$k = 0.7$ for service weather restriction III and IV.

3.1.2.2 If the weight of allocated anchor is less than 40 kg, fixing equipment for anchor cable and fixing position rather than windlass are to be provided to ensure anchoring.

3.1.2.3 The length l of anchor cable/chain is not to be less than:

$$l = 7.5 \sqrt{Q} + 20 \quad \text{m}$$

3.1.2.4 The breaking load F_s of steel anchor cable/chain is not to be less than:

$$F_s = 0.6 Q \quad \text{kN}$$

3.1.2.5 For WIG craft without windlass, anchor cable made of synthetic fiber is allowed to replace steel anchor cable. The breaking load F_f of synthetic fiber anchor cable is to be equivalent to the breaking load F_s of steel anchor chain required by 3.1.2.4.

Section 2 TOWING EQUIPMENT

3.2.1 General requirements

3.2.1.1 WIG craft are to be provided with towing equipment so that they can be towed back safely by rescue ship when losing power and floating on water.

3.2.2.2 Towing equipment is to have sufficient strength to fit safe towing operation under specified service weather restriction.

3.2.2.3 The towing equipment of lead craft is to be checked through full scale test to determine allowed maximum towing speed.

Section 3 SECURING EQUIPMENT

3.3.1 General requirements

3.3.1.1 Whether mooring at special dock or landing on ground, WIG craft are to be provided with adequate securing equipment (including bollard, fairlead and mooring cable/securing line).

3.3.1.2 The strength of securing equipment is to be sufficient to withstand wind power which may be encountered at scheduled anchorage.

Section 4 LANDING EQUIPMENT

3.4.1 Application

3.4.1.1 The provisions of this Section only apply to WIG craft which land on ground only and can not launch or disembark with own dynamic air cushion.

3.4.2 Landing frame of self-landing

3.4.2.1 The landing frame is to comply with the following requirements:

- (1) the landing frame, regardless of on launching or disembarkation, is to make the craft keep stable without uncontrollable tendency;
- (2) when taking off/landing, the landing frame is to be able to withstand impact load of wave;
- (3) the landing frame, if being damaged, is not to cause the danger due to fuel oil leakage from the fuel oil system;
- (4) course is to be controlled flexibly on planing onshore.

3.4.3 Retractable equipment of landing frame

3.4.3.1 If retractable landing frame is used, the retractable equipment and supporting structure are to have sufficient strength to withstand load caused by navigation and ground movement.

3.4.3.2 Locking devices together with corresponding indicators are to be provided for keeping the landing frame at recovering and releasing positions.

CHAPTER 4 MACHINERY AND AUXILIARY SYSTEMS

Section 1 GENERAL PROVISIONS

4.1.1 General requirements

4.1.1.1 WIG craft's power unit, machinery equipment of auxiliary system as well as design, manufacture, installation and testing of each system are to comply with relevant provisions of this Chapter or other relevant standards accepted by CCS.

4.1.1.2 Following products are to have corresponding product qualification certificate and they can not be used onboard until approval by CCS:

- (1) aeroengines;
- (2) air propellers;
- (3) valves, oil pumps, oil motors, oil filters, hydraulic elements and installations (if any) for aviation use;
- (4) pipes for aviation use.

4.1.1.3 Components of propeller and engine are to be able to prevent icing under approved environmental condition so that engine can operate in good condition.

4.1.1.4 Except for piston engine, fuel oil with flash point below 28°C is generally not allowed unless approved by CCS in special cases.

4.1.1.5 During design, anticorrosion of engine, propeller and shafting (including material selection) is to be considered as far as possible.

4.1.1.6 After installation of power unit, sea trial is to be carried out according to test program approved by CCS.

Section 2 POWER UNIT

4.2.1 General requirements

4.2.1.1 The construction, arrangement and installation of power unit of WIG craft are to comply with the following requirements:

- (1) to ensure normal operation within approved maximum navigation height;
- (2) to avoid excessive stress due to vibration within the scope of service rotating speed;
- (3) to avoid damage due to impact and corrosion as far as possible.

4.2.1.2 Engine cowling is to be dismantled or opened expediently.

4.2.2 Engine

4.2.2.1 The failure or malfunction of any engine or the failure or malfunction of any system that can affect an engine (other than a fuel tank if only one fuel tank is installed) will not:

- (1) prevent continued safe operation of the remaining engines; or
- (2) require crew to take action immediately to ensure continued safe operation of the remaining engines.

4.2.2.2 Starting requirements and relevant restriction are to be established.

4.2.2.3 The frame to install engine is to have sufficient strength.

4.2.2.4 Means for preventing the accumulation of salt deposits in the compressors and turbines are to be provided, such as effective washing system of airflow passage inside engine.

4.2.3 Propeller and shafting

4.2.3.1 The propeller, ducts and supporting system are to be so constructed and fitted as to have sufficient strength.

4.2.3.2 During design, it is to be considered that the distance between propeller blade end and water surface is suited for the visual wave height specified by service weather restriction of the craft. At any time of planing, taking off and launching, spray is not to interfere with pilot's line of vision or damage propeller and other components.

4.2.3.3 Under normal navigation condition, the vibration stress of propeller is not to exceed the stress value of continuous safe use provided by the propeller manufacturer.

4.2.3.4 The shafting, if any, is to be so designed and fitted as to have sufficient strength. Additional stress caused by torsional vibration of shafting is not to exceed the permissible values, and excessive whirling vibration and axial vibration amplitudes throughout the common speed range are not to occur.

Section 3 FUEL OIL SYSTEM

4.3.1 General requirements

4.3.1.1 The construction and arrangement of fuel oil system are to ensure normal operation of engine under various navigation condition.

4.3.1.2 The arrangement of fuel oil system is to comply with the following requirements:

- (1) Fuel oil pumps are not to pump oil simultaneously from more than one fuel tank;
- (2) Equipment to prevent air entering engine through fuel oil system is to be provided.

4.3.1.3 Fuel oil system is to be capable of preventing combustion and explosion by lightning strike.

4.3.1.4 Fuel oil system is to have measures to prevent static electricity.

4.3.2 Fuel tanks

4.3.2 In general, fuel tanks are to comply with the following requirements:

- (1) to withstand vibration, inertia and other load during navigation so as not to be damaged;
- (2) to be connected reliably with earthing system required by 5.1.1.6 of the Guidelines;
- (3) not to be easy to break under the action of inertia force during emergency landing. In addition, fuel tanks are to be located in protected safe position at which they are impossible to touch ground;
- (4) the oil tank in structural integrity is to be provided with inspection hole for inside inspection;
- (5) soft oil tanks are not to be used until approval by CCS.

4.3.2.2 The installation of fuel tank is to comply with the following requirements:

- (1) fuel tanks are to be provided outside engine room with sufficient distance between fuel tank and engine room. The wall of integral oil tank can not be treated as part of engine room bulkhead;
- (2) fuel tanks are not to be installed in the passenger compartment of WIG craft;
- (3) padding made of oil-resisting material are to be provided between fuel tank and its supporting to prevent chafing fuel tank;
- (4) each fuel tank compartment is to be ventilated and drained to prevent the accumulation of flammable fluids or vapors. Each compartment adjacent to a tank that is an integral part of structure is also to be ventilated and drained.

4.3.2.3 Each fuel tank is to have expansion space not less than 2% of the tank volume.

4.3.2.4 Each fuel tank is to be provided with a drainable sump and the sediment inside the sump is to be removed onshore. The effective volume of the sump is to be not less than 0.25% of the tank volume or 0.25l (whichever is the greater).

4.3.2.5 The oil filling port of fuel tank is to be provided with reliable filler which is not easy to lose. The filler cap is to be fuel-tight sealed but may be provided with small holes for ventilation or installation of a fuel gauge.

4.3.2.6 Each fuel tank is to be ventilated from the top part of expansion space. In addition, the following requirements are to be complied with:

- (1) ventilation openings are to be far from spaces where oil leakage or oil gas ignition may occur;

- (2) ventilation pipes are to be capable of preventing blockage by ice or other foreign matter;
 - (3) the diameter of ventilation pipe is to be big enough to allow the rapid relief of excessive differences of pressure between the interior and exterior of fuel tank;
 - (4) The expansion spaces of fuel tanks with interconnected outlets are to be connected mutually;
 - (5) The ventilation pipes are to be capable of preventing water accumulation.
- 4.3.2.7 Filters are to be provided between oil outlet of fuel tank and inlet of fuel oil gauge or inlet of engine fuel oil pump.

4.3.3 Fuel oil piping

- 4.3.3.1 For pressure fueling system, each engine is to be provided with at least one main fuel oil pump driven directly by engine.
- 4.3.3.2 Fuel oil pipes are not to pass through passenger cabin, cockpit, baggage compartment or cargo compartment as far as possible. Such penetration may be permitted provided that adequate leakage prevention measures are taken, subject to agreement of CCS.
- 4.3.3.3 Valves and fittings of fuel oil pipes are to be of steel or other equivalent material.
- 4.3.3.4 Gaskets for fuel oil piping are to be of oil and heat resisting material.
- 4.3.3.5 The installation and supporting of fuel oil piping are to be capable of preventing excessive vibration and withstanding various load.
- 4.3.3.6 If flexible hoses are used in fuel oil pipes, the hoses are to be approved by CCS or of products approved by CCS.
- 4.3.3.7 Fuel oil pipes are to be provided with stop valves capable of cutting off oil supply of each engine quickly and crew can reopen the closed valves during navigation. All stop valves in fuel oil system are not to fail due to vibration. Stop valves are not to be installed in engine room.
- 4.3.3.8 The fuel oil piping, after installation on board, is to be tightness tested with 1.5 times the design pressure.

Section 4 LUBRICATING OIL SYSTEM

4.4.1 General requirements

- 4.4.1.1 Each engine is to be provided with independent lubricating oil system. The lubricating oil pump capacity and pipe arrangement are to be capable of ensuring normal operation of engine.
- 4.4.1.2 In general, lubricating oil system is to be provided with lubricating oil low pressure alarm.

4.4.2 Lubricating oil tank

- 4.4.2.1 Lubricating oil tanks are to be capable of withstanding various vibration, inertia and other loads which may be encountered during navigation.
- 4.4.2.2 Each lubricating oil tank of piston engine is to have expansion space not less than 10% of the tank volume or 2l (whichever is the greater). Each lubricating oil tank of turbine engine is to have expansion space not less than 10% of the tank volume.
- 4.4.2.3 Lubricating oil tanks are to be ventilated from the top part of expansion space and the ventilation pipes are to be capable of preventing water accumulation.
- 4.4.2.4 The outlet diameter of lubricating oil tank is not to be less than the inlet diameter of lubricating oil pump of engine. The exit of lubricating oil tank for turbine engine is to be provided with non-return valve.

4.4.3 Heat radiation of lubricating oil

- 4.4.3.1 The sectional area of air intake pipe of lubricating oil radiator is to be big enough to have sufficient air to cool the lubricating oil.

4.4.3.2 Consideration is to be given that lubricating oil can be cooled effectively during displacement sailing of WIG craft.

Section 5 AIR INTAKE SYSTEM

4.5.1 Air inlet

4.5.1.1 The air inlet of each piston engine is to be provided with air filter.

4.5.1.2 The turbine engine is to comply with the following requirements:

- (1) The fuel leakage from oil discharge valve and air pipe of fuel oil system will not enter air intake system of engine;
- (2) The air inlet is to be so located and protected as to minimize the possibility of ingestion of foreign matter during taking off, landing and navigation.

4.5.2 Icing protection of air intake system

4.5.2.1 The air intake system of engine is to be provided with icing protection measures according to actual condition.

4.5.3 Pipelines of air intake system

4.5.3.1 The pipelines of air intake system are to be drained to prevent accumulation of moisture during normal ground and navigation condition.

Section 6 EXHAUST SYSTEM

4.6.1 General requirement

4.6.1.1 The exhaust system is to ensure that engine can discharge exhaust safely without any danger.

4.6.1.2 The exhaust discharged from exhaust system is not to enter manned space or engine intake.

4.6.1.3 Each exhaust system part with a surface hot enough to ignite flammable fluids or vapors is to be located or shielded so that leakage from any system carrying flammable fluids or vapors will not result in a fire caused by impingement of the fluids or vapors on any part of the exhaust system.

4.6.1.4 All parts of exhaust system are to be well ventilated.

4.6.2 Exhaust pipe

4.6.2.1 Where the exhaust is led overboard near the waterline, means are to be provided to prevent water siphoned back to the engine. The overboard exit of exhaust pipe is generally to be at least 300 mm above the design waterline.

4.6.2.2 The exit of exhaust pipe is to be located far from air hole or drain valve of fuel oil system.

4.6.2.3 The exhaust pipe is to have sufficient strength to prevent fire and corrosion.

Section 7 COOLING SYSTEM

4.7.1 General requirements

4.7.1.1 Cooling system is to maintain temperature of each point of power unit and accessories (such as generator and magneto) and temperature of all engine liquids within safe limits during navigation.

4.7.1.2 Thermal insulation is to be provided between high-temperature parts of engine and hull structure and sufficient cooling is to be provided to engine. Where piston engine is cooled by air, cooling air inlet is to have sufficient sectional area. Where turbine engine is cooled by liquid, cooling liquid box of sufficient volume is to be provided.

Section 8 VENTILATION SYSTEM IN ENGINE ROOM

4.8.1 General requirements

4.8.1.1 Engine room is to be ventilated compulsively or naturally to ensure ventilation and air intake necessary for engine operation. Temperature inside engine room is not to exceed 70°C.

4.8.1.2 The air intake of ventilation pipe is to be located in open position, far from exhaust pipe and provided with effective weathertight device.

Section 9 BILGE DRAINAGE SYSTEM

4.9.1 General requirements

4.9.1.1 For WIG craft of 20 m and more in length, the bilge drainage system is to comply with relevant requirements of IMO^①.

4.9.1.2 Small WIG craft of less than 20 m in length are generally to be provided with a manual drainage pump. The pump is to be kept in a compartment easy for use and capable of draining any watertight compartment.

4.9.1.3 The capacity of manual drainage pump is not to be less than that specified in Table 4.9.1.3:

Table 4.9.1.3

Length of small WIG craft (m)	Pump capacity (l)/piston stroke
Less than 8	0.6
Between 8 and 10	0.9
More than 10	1.2

4.9.1.4 For small WIG craft of more than 10 m in length with manual drainage pumps, another electric pump or pump driven by engine is to be installed. The pump is to be installed in engine room and the capacity of the pump is not to be less than 10 m³/h. The pump is to ensure drainage of engine room and adjacent compartments and cooling water pump is permitted as drainage pump.

① Refer to IMO MSC/Circ.1054 - Interim Guidelines for Wing-in-ground (WIG) Craft.

CHAPTER 5 ELECTRICAL INSTALLATIONS

Section 1 GENERAL PROVISIONS

5.1.1 General requirements

5.1.1.1 The design, manufacture and installation of main electrical installations of WIG craft are to comply with relevant provisions of this Chapter or other relevant standards accepted by CCS.

5.1.1.2 Electrical installations are to be such that:

- (1) all electrical auxiliary services necessary for maintaining the craft in normal operation and habitable conditions will be ensured without recourse to the emergency source of electrical power;
- (2) electrical services essential for safety will be ensured under various emergency conditions; and
- (3) the safety of passengers, crew and craft from electrical hazards will be ensured.

5.1.1.3 The electrical system is to be designed and installed so that the probability of the craft being at risk of failure of a service is extremely remote.

5.1.1.4 All electrical installations are to be installed permanently. The bolts and nuts used for installation, connection and fastening of electrical installations are to be effectively locked so that they can not work loose by vibration.

5.1.1.5 Aviation electrical installations and cables with product qualification certificate may be selected.

5.1.1.6 All metallic parts and metallic enclosures of all electrical installations onboard are to be connected to form a continuous conducting system. For non-metallic hull, reliable electrical connection is to be made between the conducting system and metallic earthing plate outside hull bottom, and the earthing plate is to be copper plate with not less than 200 cm² in sectional area and not less than 2 mm in thickness.

Section 2 DISTRIBUTION SYSTEM

5.2.1 Distribution system

5.2.1.1 Distribution system is the system to convey and distribute power on the WIG craft. Distribution system includes distribution bus-bars and relevant feeders as well as control and protection installations.

5.2.1.2 The following distribution systems may be provided with on WIG craft :

- (1) 28.5 V or 14 V for D.C. distribution system;
- (2) 115/200 V, 400 Hz for A.C. distribution system.

5.2.1.3 WIG craft may adopt insulation system, earthing system and hull return distribution system.

5.2.1.4 Where hull return systems are used, reliable earthing technology is to be ensured and all final sub-circuits are to have all-pole or phase insulation..

5.2.2 Protection of system

5.2.2.1 Each feeder circuit is to be protected reliably against overload and short circuits, except for main circuit of starting engine. The rating or corresponding setting of the overload protective device is to be permanently indicated at the location of the protective device.

5.2.2.2 If the protective device is fuse, it is to be installed at the electrical power side of protected circuit breaking switch.

5.2.2.3 If the capability of resetting certain circuit-breaker or replacing certain fuse is required according to navigation safety, the position of this circuit-breaker or fuse is to be readily accessible to navigator.

Section 3 ELECTRICAL POWER

5.3.1 Provision of and requirements to electrical power

5.3.1.1 WIG craft are to be at least provided with one set of main source of electrical power and one set of emergency source of electrical power. The total capacity of each set of main source of electrical power is to satisfy the power supply of electrical equipment necessary for safe navigation of WIG craft, and the total capacity of emergency source of electrical power is to satisfy the power supply of electrical equipment necessary for safety of WIG craft as well as navigation operation upon failure of main engine.

5.3.1.2 Main source of electrical power may be an accumulator battery or generator driven by main engine.

5.3.1.3 Main source of electrical power is to comply with the following requirements:

- (1) except that the generator may be initially excited or stabilized depending on the accumulator battery, the electrical power is to be in good working condition during parallel or separate operation;
- (2) except that the generator of which initial excitation or stabilization depends on the accumulator battery may stop operation due to failure of accumulator battery, supply of other electrical power to the equipment necessary for safe navigation is not to be endangered or damaged upon failure of any electrical power;
- (3) if floating power supply is carried out to accumulator battery with higher D.C. voltage by main bus-bar, normal operation of electrical equipment is to be ensured;
- (4) each generator (except for silicon rectifier generator) is to be provided with reverse current device to disconnect each generator and accumulator battery as well as other generators and prevent damage to generator due to reverse current and adverse effect to electrical system;
- (5) warning must be made to the cockpit immediately upon failure of any one generator;
- (6) voltage regulator of generator is to be capable of regulating the output voltage of generator reliably to the extent of rated value;
- (7) Each generator is to be protected against overload, short-circuit and over-voltage.

5.3.1.4 The emergency source of electrical power may be either a generator or an accumulator battery, which is to comply with the following:

- (1) Where the emergency source of electrical power is a generator, it is to be driven by a suitable power unit with an independent supply of fuel oil, started automatically upon failure of the electrical supply from the main source of electrical power and automatically connected to emergency bus-bar within 45s.
- (2) Where the emergency source of electrical power is an accumulator battery, it is to be capable of carrying the emergency electrical load without recharging while maintaining the voltage of the battery throughout the discharge period within 12% above or below its nominal voltage.
- (3) Simple method is to be provided with to inspect whether the emergency source of electrical power is in applicable condition.

5.3.1.5 The emergency source of electrical power is to be capable of supplying simultaneously at least the following services for 2h:

- (1) emergency lighting:
 - ① at the stowage positions of life-saving appliances;
 - ② at all escape routes, such as alleyways, stairways, exits from service spaces, embarkation points, etc.;
 - ③ in the public spaces;
 - ④ in the machinery spaces and main emergency generating spaces including their control positions;
 - ⑤ in control stations;

- (2) signal lamps;
- (3) public address system or electrical internal communication equipment for announcements for passengers and crew required during evacuation;
- (4) fire-detection and alarm system and manual fire alarm (if any);
- (5) remote control devices of fire-extinguishing systems, if electrical;
- (6) radio facilities required by Interim Provisions for Statutory Survey of Wing-in-ground (WIG) Craft;
- (7) essential electrically powered instruments and controls for propulsion machinery, if alternate sources of power are not available for such devices.

5.3.1.6 Where main source of electrical power is only composed of an accumulator battery or the emergency source of electrical power is an accumulator battery, the accumulator battery is to be charged to full capacity by a source on shore before sailing.

5.3.1.7 The capacity of electrical power is to be determined according to operation requirements of WIG craft. Electrical loading is to be analyzed, considering each service condition of WIG craft, load increase and necessary allowance, and Calculations for Electrical Load Analysis is to be prepared.

5.3.1.8 A main switch is to be provided between main source of electrical power and main bus-bar, and the disconnecting point is to be near the electrical power controlled by the switch. The installation of main switch or the control equipment is to be readily identifiable and accessible to the navigator during navigation. Measures are to be taken to prevent the risk of power supply being interrupted by inadvertent or accidental switching off main switch.

5.3.1.9 Voltmeter and ammeter of each generator are to be provided in navigating position. Where main source of electrical power is an accumulator battery, voltmeter and ammeter are also to be provided. If a set of instrument is shared by several generators, each generator is to be provided with an independent failure indicator.

5.3.1.10 Shore power equipment is to be provided with polarity protection (for D.C.) or phase sequence indication (for A.C.).

5.3.1.11 Voltmeters, voltage coils of measuring instruments and control equipment, pilot lamps together with their connecting leads are to be protected by fuses.

5.3.1.12 Separate batteries are to be provided as starting power for engine.

5.3.2 Accumulator batteries

5.3.2.1 Accumulator batteries (except for those used as starting generator) are to be provided with short-circuit protection and the protection installations are to be as near accumulator batteries as possible.

5.3.2.2 Automatic discharge equipment of accumulator batteries is to ensure automatic power supply at any time whether the accumulator batteries are in charging condition or not.

5.3.2.3 Accumulator batteries (except for valve controlled accumulator batteries) are to be installed in a special box with independent ventilation. Accumulator batteries and the box are to be installed reliably and permanently and not to be installed in the wheelhouse or passenger compartment.

5.3.2.4 The construction and fastening method of all accumulator batteries are to prevent spillage of electrolytes. The corrosive liquid or gas which may be leaked from accumulator batteries is not to damage surrounding structure of WIG craft or adjacent important equipment.

5.3.2.5 The monitor of accumulator batteries is to satisfy the requirements of system safety and reliability and indications of battery discharging and low voltage are to be provided in the wheelhouse.

Section 4 CABLES

5.4.1 General requirements

5.4.1.1 All electric cables are to be at least of a halogen-free flame-retardant type complying with the requirements of IEC 60332-3 and so installed as not to impair their original flame-retarding properties. Where necessary for particular applications, CCS may permit the use of special types of cables which do not comply with above-mentioned requirements, such as radio frequency cables or digital computer information transmission system cables.

5.4.1.2 Each cable is to have sufficient current rating.

5.4.1.3 Cable runs are to be, as far as possible, straight and accessible and to avoid damage.

5.4.1.4 The main cables laid in the body (including generator cables) are to be so designed that they will not fail under reasonable deformation and tension. The insulated coating of cable is to be covered by non-combustible material, and the load carried is to be reduced.

5.4.1.5 Cable runs are normally not to include joints. If, in the case of repair or sectional construction of the craft, a joint is necessary, the joint is to be of such a type that electrical continuity, insulation, mechanical strength and protection, earthing and fire-resisting or flame-retardant characteristics are not to be less than those required for the cables.

Section 5 LIGHTING

5.5.1 General requirements

5.5.1.1 The number of lighting points supplied by each final sub-circuit of rating 16 A or less at the lighting distribution boards is not to exceed:

- (1) 10 points for D.C.;
- (2) 14 points for A.C..

5.5.1.2 The lighting for passageways, public spaces as well as berthing compartments accommodating more than 16 passengers is to be supplied by two final sub-circuits.

5.5.1.3 In passenger craft, the means of escape are to be marked by lighting or photo-luminescent strip indicators approved by CCS placed not more than 0.3 m above the deck at all points of the escape route. The marking must enable passengers to identify all the routes of escape and readily identify the escape exits. If illumination is used, it is to be supplied by the emergency source of power.

5.5.1.4 Each lighting circuit is to be protected against overload and short-circuit.

Section 6 LIGHTNING ARRESTING

5.6.1 General requirements

5.6.1.1 Catastrophic consequences to WIG craft due to lightning are to be avoided:

- (1) metallic components are to be bonded to hull correctly;
- (2) for non-metallic components, acceptable measures are to be provided to divert current so that the craft will not be endangered, e.g. using good conductor to cover it.

CHAPTER 6 MATERIALS AND BUILDING TECHNIQUE

Section 1 GENERAL PROVISIONS

6.1.1 General requirements

6.1.1.1 This Chapter applies to WIG craft of which the hull and main parts are made of aluminum alloy and fiber-reinforced plastics.

6.1.1.2 Materials and building technique for WIG craft are to comply with relevant provisions of CCS Rules for Materials and Welding and other equivalent standards accepted by CCS.

6.1.1.3 Corrosion protection is to be provided for riveting between two different metallic material to prevent electrochemical corrosion.

Section 2 ADDITIONAL REQUIREMENTS FOR RIVETING

6.2.1 General requirements

6.2.1.1 Riveting may be adopted for thin plate structure of WIG craft.

6.2.1.2 For metallic structure, cold rivet by means of impact may be permitted. Cold rivet by means of non-impact is to be used for rivet between metal and composite material as well as glue riveting.

6.2.1.3 Minimum diameter of rivet shank is to be considered for calculation of rivet diameter. Rivet material is to be selected according to the brand of connecting structural material and corrosion requirements are to be taken into account. The rivet diameter d may be calculated according to following formula and then be selected according to rivet standard specification:

$$d \geq 2\sqrt{\sum \delta}$$

where: $\sum \delta$ — total thickness of attachments (including thickness of gasket), in mm, see Figure 6.2.1.3.

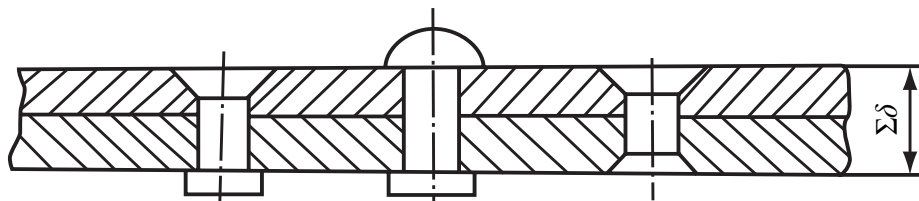

Figure 6.2.1.3

6.2.1.4 Rivet seam and rivet

(1) During riveting, the minimum width of plate bond is not to be less than those specified in Table 6.2.1.4(1).

Minimum width of plate bond**Table 6.2.1.4(1)**

Number of rivet seam	Minimum width (mm)
Single row	$4d$
Two rows	$6d$
Three rows	$8d$

Note: d is rivet diameter, in mm.

(2) For rivet spacing, row interval, row number and arrangement, refer to Table 6.2.1.4(2).

Rivet spacing, row interval, row number and arrangement Table 6.2.1.4(2)

Type of rivet seam	Rivet spacing (mm)	Rivet row interval (mm)	Rivet row number	Rivet arrangement
Normal rivet seam	$6\sim 7d$	$2\sim 5d$	1 on the frame, 2 on the joint	Staggered or parallel Staggered
Tight rivet seam	$4\sim 5d$	$2d$	2~3	staggered

Note: d is rivet diameter, in mm.

(3) The last rivet spacing is to be within the scope of $0.7\sim 1.3t$ (t being rivet spacing). If this requirement can not be satisfied, last two spacings are to be divided evenly, but the minimum spacing is to be less than 3 times the rivet diameter.

(4) The minimum margin of rivet is not to be less than $2d$.

(5) In general, the rivet length is selected according to Table 6.2.1.4(5). The diameter of rivet hole is to be 0.1mm more than rivet diameter.

Rivet length**Table 6.2.1.4(5)**

Type of closing heads	Countersink head	Semi-countersink head	Flat head	Semi-globe head
Rivet length	$\Sigma \delta + 0.9d$	$\Sigma \delta + 1.1d$	$\Sigma \delta + 1.2d$	$\Sigma \delta + 1.3d$

Note: $\Sigma \delta$ is total thickness of attachments (including thickness of gasket), in mm. d is rivet diameter, in mm.

(6) The rivet heads are to be free from cut, excavation, crack and other mechanical damage. After riveting, rivet heads are to be tightly pressed against the surface of parts. The skin around rivet head dents not more than 0.35mm and no gap is allowed between parts at rivet. The riveted pieces are to be free from pits, bump and cuts.

6.2.2 Tight riveting

6.2.2.1 In addition to the requirements of above 6.1, the tight riveting technique process and procedure for the structure with watertightness requirements are to comply with the requirements of Table 6.2.2.1.

Riveting technique processes and procedures **Table 6.2.2.1**

Item	Riveting process	Procedure	Technique method
1	Preassembly	Installation positioning and fastening of parts	The same as the requirements of ordinary riveting
2	Boring and reaming	Drilling all rivet holes and reaming	The same as the requirements of ordinary riveting
3	Separating and cleaning	Separating parts and removing metal filings and burrs	The same as the requirements of ordinary riveting
4	Laying sealing material	Cleaning the surface of parts to be laid with sealing material and removing oil	Wiping with fine cloth dipped into gasoline or acetone until no oil is found
		Laying sealing material on the parts	1. brushing sealing glue; 2. laying glue film; 3. laying multi-sulphur sealing tape and sealing putty tape and flattening by steel roller
5	Final assembly	Fixing the separated parts according to preassembly position	1. fixing bolts to make parts close assembled 2. puncturing rivet hole with special awl
6	Riveting	Putting rivets for riveting	By means of pressing rivets or inversing hammering rivets
7	Sulphuration ^①	Riveting parts with sealing glue to be sulphurated	1. sulphuration at ambient temperature 2. warming sulphuration
8	Procedure survey	Inspecting quality of positioning holes, bores, reams, riveting and rivet seam tightness	The same as the requirements of Section 3 of this Chapter

Note: ① Sulphuration temperature and time are according to technical condition.

Section 3 QUALITY INSPECTION

6.3.1 Inspection of welds

6.3.1.1 Visual inspection is to be carried out on all the finished welds. The dimensions of the welds are to comply with the requirements of plans or relevant standards and the surfaces of welds are to be smooth and uniform.

6.3.1.2 The surfaces of the welds are to be free from defects such as cracks, tungsten inclusions, unfills, blister, bum-troughs, super burning and overlaps, etc. Undercuts are not permitted for plates of thickness of 3 mm or less. For plates of thickness over 3 mm, the depth of undercut is not to be greater than 0.5 mm, and the total length is not to be greater than 10% of the length of a single weld, and is not to exceed 100 mm.

6.3.1.3 The welds of main hull structure are to be subject to non-destructive test, the testing range is to be determined by consultation of the manufacturer and the Surveyor. It is recommended that at least 5% of the main butt welds of the hull structure be radiographic tested. Fillet welds of important structures are to be ultrasonic tested. The defects are to be evaluated in accordance with the standards accepted by CCS.

6.3.1.4 If non-destructive testing is necessary for hull structure, detailed testing procedures are to be prepared by the manufacturer and submitted to the Surveyor for approval. The intended testing method, testing range and arrangement of testing points are to be included in the testing procedures.

6.3.2 Inspection of riveted seams

6.3.2.1 The rivet spacing, row interval and diameter of rivets are to comply with the requirements of the plan.

6.3.2.2 After riveting, the surfaces of the units around the rivet are to be tightly pressed against each other and no obvious indentation is to be found at the riveting place.

6.3.2.3 The dimensions of the heads of the rivets are to comply with relevant standards. The rivets are to be free from loosening, deviation of heads and cracks, etc.

6.3.3 Inspection of sealing quality

6.3.3.1 The overall sealing process is to be controlled and inspected, including washing sealed surface as well as preparing, applying and protecting sealants.

6.3.3.2 The sealed parts are to be free from misapplication, starved, blow holes, defects and inclusions.

6.3.3.3 Structure assembly is not to be carried out until the members of sealed structure are confirmed to be tight by inspection.

6.3.3.4 Sealants are to be inspected and confirmed to be free from flakes.

6.3.4 Inspection of connection

6.3.4.1 The connection joints of structure are to be accessible for inspection. The delamination risk of multi-layer material of connecting structure is to be removed and joints are to be inspected by tests if necessary.

6.3.4.2 Rivets, bolts and gaskets are to be made of anti-corrosive material or protected against corrosion.

6.3.4.3 The diameter of bolt hole is to match the diameter of bolt. The distance from the hole center to multi-layer material edge is not to be less than 3 times the diameter of rivet or bolt.

6.3.4.4 For connection subjected to stress, gaskets are to be laid below bolt head and nut. The external diameter of gasket is not to be less than twice the hole diameter and the thickness of gasket is to be 0.1 times of the hole diameter but not less than 0.5 mm. If the dimensions of bolt head comply with the requirements to gasket, gasket may be exempted. For connection under special strained condition, it is recommended to use enlarged gasket.

6.3.4.5 For watertight connection, tightness is to be obtained by arranging rivets or bolts.

6.3.4.6 Threaded joints may be used for connection subjected to small stress. The decision of using thread tightened parts is to be made according to test results of each detailed condition. Thread tightening is to be arranged vertical to multi-layer material as far as practicable. The thickness of thread tightened material is to be not less than 5 mm, or stiffened plates are to be provided for multi-layer material.

6.3.5 Weighing

6.3.5.1 During construction, each part of structure is to be weighed.