

## P3 Air Pipe Closing Devices

(1991)  
(Corr.1  
May  
1998)  
(Rev.1  
May  
2001)  
(Corr.1  
April  
2002)  
(Rev.2  
Mar  
2004)  
(Rev.3  
Nov  
2012)

### P3.1 General requirements

Where air pipes are required by the Rules or Load Line Convention, 1966 to be fitted with automatic closing devices, they are to comply with the following:

### P3.2 Design

P3.2.1 Air pipe automatic closing devices are to be so designed that they will withstand both ambient and working conditions, and be suitable for use at inclinations up to and including  $\pm 40^\circ$ .

P3.2.2 Air pipe automatic closing devices are to be constructed to allow inspection of the closure and the inside of the casing as well as changing the seals.

P3.2.3 Efficient ball or float seating arrangements are to be provided for the closures. Bars, cage or other devices are to be provided to prevent the ball or float from contacting the inner chamber in its normal state and made in such a way that the ball or float is not damaged when subjected to water impact due to a tank being overfilled.

P3.2.4 Air pipe automatic closing devices are to be self-draining.

P3.2.5 The clear area through an air pipe closing device in the open position is to be at least equal to the area of the inlet.

P3.2.6 An automatic closing device is to:

- a) Prevent the free entry of water into the tanks,
- b) Allow the passage of air or liquid to prevent excessive pressure or vacuum coming on the tank.

P3.2.7 In the case of air pipe closing devices of the float type, suitable guides are to be provided to ensure unobstructed operation under all working conditions of heel and trim as specified in 3.2.1.

P3.2.8 The maximum allowable tolerances for wall thickness of floats should not exceed  $\pm 10\%$  of thickness.

P3.2.9 The inner and the outer chambers of an automatic air pipe head is to be of a minimum thickness of 6 mm.

---

Note:

1. Revision 3 of this UR is to be applied by IACS Societies to any air pipe closing device submitted for new or revised approval from 1 January 2014.

**P3**  
(cont)**P3.3 Materials**

P3.3.1 Casings of air pipe closing devices are to be of approved metallic materials adequately protected against corrosion.

P3.3.2 For galvanised steel air pipe heads, the zinc coating is to be applied by the hot method and the thickness is to be 70 to 100 microns.

P3.3.3 For areas of the head susceptible to erosion (e.g. those parts directly subjected to ballast water impact when the tank is being pressed up, for example the inner chamber area above the air pipe, plus an overlap of 10° or more either side) an additional harder coating should be applied. This is to be an aluminium bearing epoxy, or other equivalent, coating, applied over the zinc.

P3.3.4 Closures and seats made of non-metallic materials are to be compatible with the media intended to be carried in the tank and to seawater and suitable for operating at ambient temperatures between -25°C and 85°C.

**P3.4 Type Testing****P3.4.1 Testing of Air Pipe Automatic Closing Devices**

Each type and size of air pipe automatic closing device is to be surveyed and type tested at the manufacturer's works or other acceptable location according to the Classification Society's practice. The minimum test requirements for an air pipe automatic closing device are to include the following:

a) Determination of the Flow Characteristics.

The flow characteristics of the air pipe closing device are to be determined. Measuring of the pressure drop versus rate of volume flow is to be carried out using water and with any intended flame or insect screens in place.

b) Tightness test during immersion/emerging in water.

An automatic closing device is to be subjected to a series of tightness tests involving not less than two (2) immersion cycles under each of the following conditions:

- i) The automatic closing device is to be submerged slightly below the water surface at a velocity of approximately 4 m/min. and then returned to the original position immediately. The quantity of leakage is to be recorded.
- ii) The automatic closing device is to be submerged to a point slightly below the surface of the water. The submerging velocity is to be approximately 8 m/min and the air pipe vent head is to remain submerged for not less than 5 minutes. The quantity of leakage shall be recorded.
- iii) Each of the above tightness tests shall be carried out in the normal position as well as at an inclination of 40 degrees under the strictest conditions for the device. In cases where such strictest conditions are not clear, tests shall be carried out at an inclination of 40 degrees with the device opening facing in three different directions: upward, downward, sideways (left or right). (See Figure 1 to 4).

**P3**  
(cont)

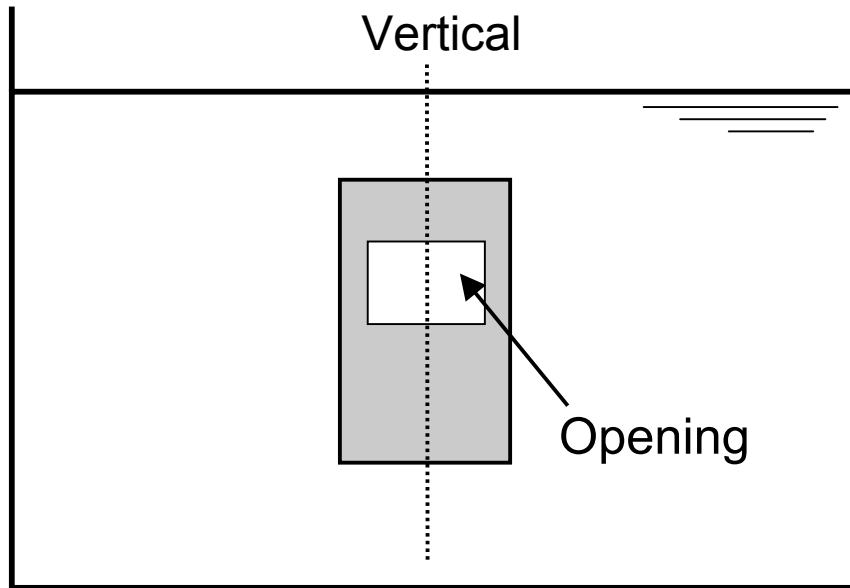

Fig 1: Example of normal position

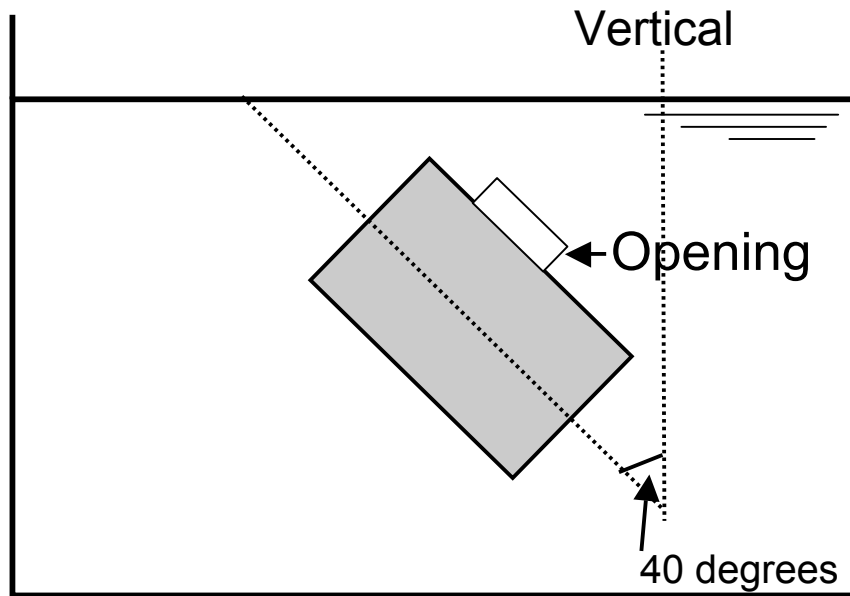
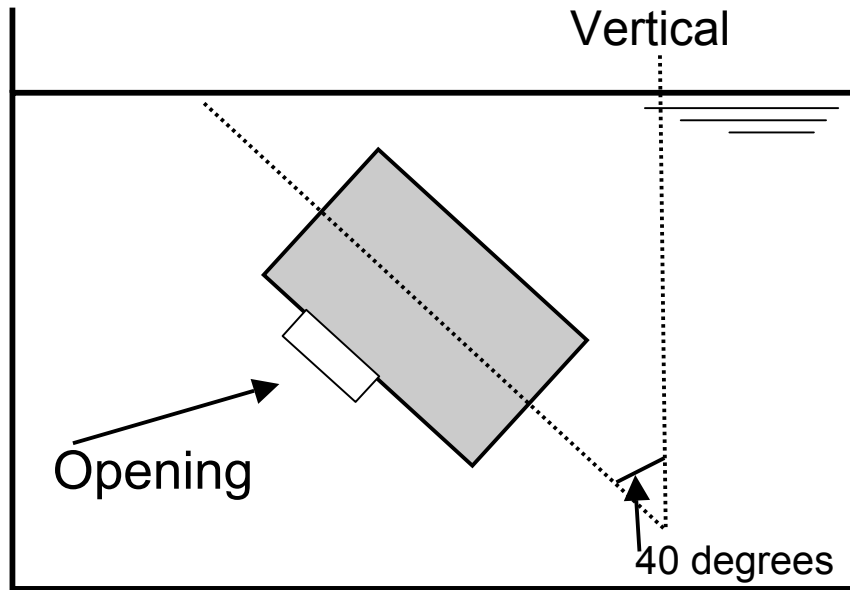
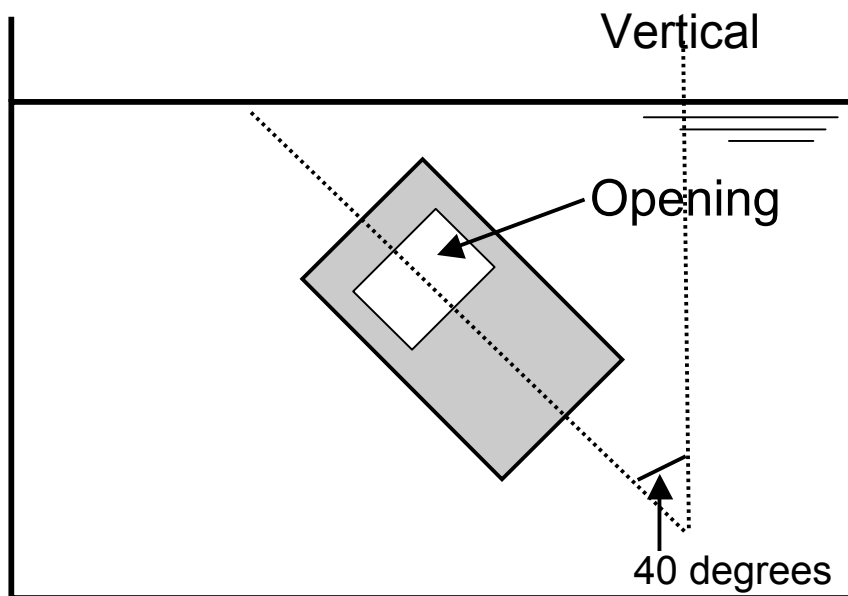

Fig 2: Example of inclination 40 degrees opening facing upward

**P3**  
(cont)



**Fig 3: Example of inclination 40 degrees opening facing downward**



**Fig 4: Example of inclination 40 degrees opening facing sideways**

## P3 (cont)

### c) Discharge / Reverse flow test

The air pipe head shall allow the passage of air to prevent excessive vacuum developing in the tank. A reverse flow test shall be performed. A vacuum pump or another suitable device shall be connected to the opening of the air pipe leading to the tank. The flow velocity shall be applied gradually at a constant rate until the float gets sucked and blocks the flow. The velocity at the point of blocking shall be recorded. 80% of the value recorded will be stated in the certificate.

The maximum allowable leakage per cycle shall not exceed 2 ml/mm of nominal diameter of inlet pipe during any individual test.

#### P3.4.2 Testing of non-metallic Floats

Impact and compression loading tests shall be carried out on the floats before and after pre-conditioning as follows:

Test condition	Test temperature °C		
	-25	20	85
Dry	+	+	+
After immersing in water	+	+	+
After immersing in fuel oil	-	+	-
Immersing in water and fuel oil is to be for at least 48 hours			

#### a) Impact Test

The test may be conducted on a pendulum type testing machine. The floats shall be subjected to 5 impacts of 2.5 Nm each and shall not suffer permanent deformation, cracking or surface deterioration at this impact loading.

Subsequently the floats shall be subjected to 5 impacts of 25 Nm each. At this impact energy level some localised surface damage at the impact point may occur. No permanent deformation or cracking of the floats shall appear.

#### b) Compression Loading Test

Compression tests shall be conducted with the floats mounted on a supporting ring of a diameter and bearing area corresponding to those of the float seating with which it is intended that float shall be used. For ball type float, loads shall be applied through a concave cap of the same internal radius as the test float and bearing on an area of the same diameter as the seating. For a disc type float, loads are to be applied through a disc of equal diameter as the float.

A load of 350 kg shall be applied over one minute and maintained for 60 minutes. The deflection shall be measured at intervals of 10 minutes after attachment of the full load. The record of deflection against time is to show no continuing increase in deflection and, after release of the load, there shall be no permanent deflection.

#### P3.4.3 Testing of Metallic Floats

Tests shall be conducted in accordance with 3.4.2 a). The tests shall be carried out at room temperature and in the dry condition.

End of Document
--------------------