

No.47 Shipbuilding and Repair Quality Standard

(1996)

(Rev. 1, 1999)

(Rev.2, Dec. 2004)

(Rev.3, Nov. 2006)

(Rev.4, Aug. 2008)

(Rev.5, Oct. 2010)

(Rev.6, May 2012)

Part A Shipbuilding and Remedial Quality Standard for New Construction

Part B Repair Quality Standard for Existing Ships

PART A - SHIPBUILDING AND REMEDIAL QUALITY STANDARDS FOR NEW CONSTRUCTION

1. Scope

2. General requirements for new construction

3. Qualification of personnel and procedures

3.1 Qualification of welders

3.2 Qualification of welding procedures

3.3 Qualification of NDE operators

4. Materials

4.1 Materials for structural members

4.2 Surface conditions

5. Gas Cutting

6. Fabrication and fairness

6.1 Flanged longitudinals and flanged brackets

6.2 Built-up sections

6.3 Corrugated bulkheads

6.4 Pillars, brackets and stiffeners

6.5 Maximum heating temperature on surface for line heating

6.6 Block assembly

6.7 Special sub-assembly

6.8 Shape

6.9 Fairness of plating between frames

6.10 Fairness of plating with frames

6.11 Preheating for welding hull steels at low temperature

7. Alignment

8. Welding Joint Details

8.1 Typical butt weld plate edge preparation (manual welding and semi-automatic welding)

8.2 Typical fillet weld plate edge preparation (manual welding and semi-automatic welding)

8.3 Butt and fillet weld profile (manual welding and semi-automatic welding)

8.4 Typical butt weld edge preparation (Automatic welding)

8.5 Distance between welds

9. Remedial

9.1 Typical misalignment remedial

9.2 Typical butt weld plate edge preparation remedial (manual welding and semi-automatic welding)

9.3 Typical fillet weld plate edge preparation remedial (manual welding and semi-automatic welding)

9.4 Typical fillet and butt weld profile remedial (manual welding and semi-automatic welding)

9.5 Distance between welds remedial

9.6 Erroneous hole remedial

9.7 Remedial by insert plate

9.8 Weld surface remedial

9.9 Weld remedial (short bead)

REFERENCES

1. IACS "Bulk Carriers - Guidelines for Surveys, Assessment and Repair of Hull Structure"
2. TSCF "Guidelines for the inspection and maintenance of double hull tanker structures"
3. TSCF "Guidance manual for the inspection and condition assessment of tanker structures"
4. IACS UR W7 "Hull and machinery steel forgings"
5. IACS UR W8 "Hull and machinery steel castings"
6. IACS UR W11 "Normal and higher strength hull structural steel"
7. IACS UR W13 "Thickness tolerances of steel plates and wide flats"
8. IACS UR W14 "Steel plates and wide flats with specified minimum through thickness properties ("Z" quality)"
9. IACS UR W17 "Approval of consumables for welding normal and higher strength hull structural steels"
10. IACS UR W28 "Welding procedure qualification tests of steels for hull construction and marine structures"
11. IACS UR Z10.1 "Hull surveys of oil tankers" and Z10.2 "Hull surveys of bulk carriers" Annex I
12. IACS UR Z23 "Hull survey for new construction"
13. IACS Recommendation No. 12 "Guidelines for surface finish of hot rolled plates and wide flats"
14. IACS Recommendation No. 20 "Non-destructive testing of ship hull steel welds"

1. Scope

It is intended that these standards provide guidance where established and recognized shipbuilding or national standards accepted by the Classification Society do not exist.

1.1 This standard provides guidance on shipbuilding quality standards for the hull structure during new construction and the remedial standard where the quality standard is not met.

Whereas the standard generally applies to

- conventional merchant ship types,
- parts of hull covered by the rules of the Classification Society,
- hull structures constructed from normal and higher strength hull structural steel,

the applicability of the standard is in each case to be agreed upon by the Classification Society.

The standard does generally not apply to the new construction of

- special types of ships as e.g. gas tankers
- structures fabricated from stainless steel or other, special types or grades of steel

1.2 In this standard, both a "Standard" range and a "Limit" range are listed. The "Standard" range represents the target range expected to be met in regular work under normal circumstances. The "Limit" range represents the maximum allowable deviation from the "Standard" range. Work beyond the "Standard" range but within the "Limit" range is acceptable. In cases where no 'limit' value is specified, the value beyond the 'standard' range may be accepted subject to the consideration of the Classification Society.

1.3 The standard covers typical construction methods and gives guidance on quality standards for the most important aspects of such construction. Unless explicitly stated elsewhere in the standard, the level of workmanship reflected herein will in principle be acceptable for primary and secondary structure of conventional designs. A more stringent standard may however be required for critical and highly stressed areas of the hull, and this is to be agreed with the Classification Society in each case. In assessing the criticality of hull structure and structural components, reference is made to ref. 1, 2 and 3.

1.4 Details relevant to structures or fabrication procedures not covered by this standard are to be approved by the Classification Society on the basis of procedure qualifications and/or recognized national standards.

1.5 For use of this standard, fabrication fit-ups, deflections and similar quality attributes are intended to be uniformly distributed about the nominal values. The shipyard is to take corrective action to improve work processes that produce measurements where a skew distribution is evident. Relying upon remedial steps that truncate a skewed distribution of the quality attribute is unacceptable.

2. General requirements for new construction

2.1 In general, the work is to be carried out in accordance with the Classification Society rules and under the supervision of the Surveyor to the Classification Society

2.2 Welding operations are to be carried out in accordance with work instructions accepted by the Classification Society.

2.3 Welding of hull structures is to be carried out by qualified welders, according to approved and qualified welding procedures and with welding consumables approved by the Classification Society, see Section 3. Welding operations are to be carried out under proper supervision by the shipbuilder. The working conditions for welding are to be monitored by the Classification Society in accordance with UR Z23.

3. Qualification of personnel and procedures

3.1 Qualification of welders

3.1.1 Welders are to be qualified in accordance with the procedures of the Classification Society or to a recognized national or international standard. Recognition of other standards is subject to submission to the

Classification Society for evaluation. Subcontractors are to keep records of welders qualification and, when required, furnish valid approval test certificates.

3.1.2 Welding operators using fully mechanized or fully automatic processes need generally not pass approval testing provided that the production welds made by the operators are of the required quality. However, operators are to receive adequate training in setting or programming and operating the equipment. Records of training and operation experience shall be maintained on individual operator's files and records, and be made available to the Classification Society for inspection when requested.

3.2 Qualification of welding procedures

Welding procedures are to be qualified in accordance with URW28 or other recognized standard accepted by the Classification Society.

3.3 Qualification of NDE operators

Personnel performing non-destructive examination for the purpose of assessing quality of welds in connection with new construction covered by this standard, are to be qualified in accordance with Classification Society rules or to a recognized international or national qualification scheme. Records of operators and their current certificates are to be kept and made available to the Surveyor for inspection.

4. Materials

4.1 Materials for Structural Members

All materials, including weld consumables, to be used for the structural members are to be approved by the Classification Society as per the approved construction drawings and meet the respective IACS Unified Requirements. Additional recommendations are contained in the following paragraphs.

All materials used should be manufactured at a works approved by the Classification Society for the type and grade supplied.

4.2 Surface Conditions

4.2.1 Definitions

Minor Imperfections: Pitting, rolled-in scale, indentations, roll marks, scratches and grooves
 Defects: Cracks, shells, sand patches, sharp edged seams and minor imperfections exceeding the limits of table 1
 Depth of Imperfections or defects: The depth is to be measured from the surface of the product

4.2.2 Acceptance without remedies

Minor imperfections, in accordance with the nominal thickness (t) of the product and the limits described in Table 1, are permissible and may be left as they are.

Imperfection surface area Ratio(%)	15~20%	5~15%	0~5%
t < 20 mm	0.2 mm	0.4 mm	0.5 mm
20 mm ≤ t < 50 mm	0.2 mm	0.6 mm	0.7 mm
50 mm ≤ t	0.2 mm	0.7 mm	0.9 mm

Table 1 Limits for depth of minor imperfection, for acceptance without remedies

Imperfection surface area Ratio (%) is obtained as influenced area / area under consideration (i.e. plate surface area) x 100%.

For isolated surface discontinuities, influenced area is obtained by drawing a continuous line which follows the circumference of the discontinuity at a distance of 20 mm. (Figure 1)

For surface discontinuities appearing in a cluster, influenced area is obtained by drawing a continuous line which follows the circumference of the cluster at a distance of 20 mm. (Figure 2)

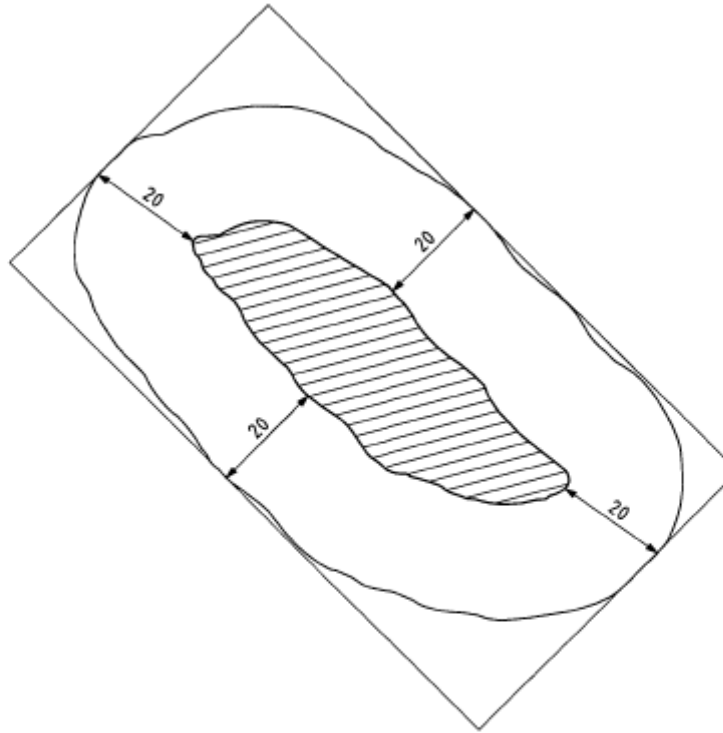

Figure 1 - Determination of the area influenced by an isolated discontinuity
(Ref. Nr. EN 10163-1:2004+AC:2007 E)

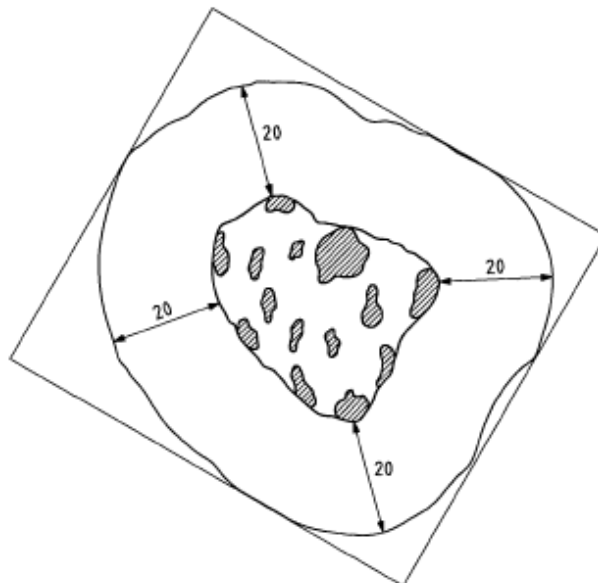

Figure 2 - Determination of the area influenced by clustered discontinuities
(Ref. Nr. EN 10163-1:2004+AC:2007 E)

4.2.3 Remedial of Defects

Defects are to be remedied by grinding and/or welding in accordance with IACS Rec.12.

4.2.4 Further Defects

4.2.4.1 Lamination

Investigation to be carried out at the steelmill into the cause and extent of the detected laminations. Severe lamination is to be remedied by local insert plates. The minimum breadth or length of the plate to be replaced is to be:

- 1600 mm for shell and strength deck plating in way of cruciform or T-joints,
- 800 mm for shell, strength deck plating and other primary members,
- 300 mm for other structural members.

Local limited lamination may be remedied by chipping and/or grinding followed by welding in accordance with sketch (a). In case where the local limited lamination is near the plate surface, the remedial may be carried out as shown in sketch (b). For limitations see paragraph 4.2.2.



4.2.4.2 Weld Spatters

Loose weld spatters are to be removed by grinding or other measures to clean metal surface (see Table 9.13), as required by the paint system, on:

- shell plating
- deck plating on exposed decks
- in tanks for chemical cargoes
- in tanks for fresh water and for drinking water
- in tanks for lubricating oil, hydraulic oil, including service tanks

5. Gas Cutting

The roughness of the cut edges is to meet the following requirements:

Free Edges:

	Standard	Limit
Strength Members	150 µm	300 µm
Others	500 µm	1000 µm

Welding Edges:

	Standard	Limit
Strength Members	400 µm	800 µm
Others	800 µm	1500 µm

6. Fabrication and fairness

- 6.1 Flanged longitudinals and flanged brackets (see Table 6.1)
- 6.2 Built-up sections (see Table 6.2)

- 6.3 Corrugated bulkheads (see Table 6.3)
- 6.4 Pillars, brackets and stiffeners (see Table 6.4)
- 6.5 Maximum heating temperature on surface for line heating (see Table 6.5)
- 6.6 Block assembly (see Table 6.6)
- 6.7 Special sub-assembly (see Table 6.7)
- 6.8 Shape (see Table 6.8 and 6.9)
- 6.9 Fairness of plating between frames (see Table 6.10)
- 6.10 Fairness of plating with frames (see Table 6.11)
- 6.11 Preheating for welding hull steels at low temperature (See Table 6.12)

7. Alignment

The quality standards for alignment of hull structural components during new construction are shown in Tables 7.1, 7.2 and 7.3. The Classification Society may require a closer construction tolerance in areas requiring special attention, as follows:

- Regions exposed to high stress concentrations
- Fatigue prone areas
- Detail design block erection joints
- High tensile steel regions

8. Welding Joint Details

Edge preparation is to be qualified in accordance with URW28 or other recognized standard accepted by the Classification Society.

Some typical edge preparations are shown in Table 8.1, 8.2, 8.3, 8.4 and 8.6 for reference.

- 8.1 Typical butt weld plate edge preparation (manual and semi-automatic welding) for reference - see Table 8.1 and 8.2
- 8.2 Typical fillet weld plate edge preparation (manual and semi-automatic welding) for reference - see Table 8.3 and 8.4
- 8.3 Butt and fillet weld profile (manual and semi-automatic welding) - see Table 8.5
- 8.4 Typical butt weld plate edge preparation (Automatic welding) for reference - see Table 8.6
- 8.5 Distance between welds - see Table 8.7

9. Remedial

All the major remedial work is subject to reporting by shipbuilder to the Classification Society for approval in accordance with their work instruction for new building.

Some typical remedial works are shown in Tables 9.1 to 9.13.

- 9.1 Typical misalignment remedial - see Tables 9.1 to 9.3
- 9.2 Typical butt weld plate edge preparation remedial (manual and semi-automatic welding) - see Table 9.4 and 9.5
- 9.3 Typical fillet weld plate edge preparation remedial (manual and semi-automatic welding) - see Tables 9.6 to 9.8
- 9.4 Typical fillet and butt weld profile remedial (manual and semi-automatic welding) - see Table 9.9
- 9.5 Distance between welds remedial - see Table 9.10
- 9.6 Erroneous hole remedial - see Table 9.11
- 9.7 Remedial by insert plate - see Table 9.12
- 9.8 Weld surface remedial - see Table 9.13
- 9.9 Weld remedial (short bead) - see Table 9.14

TABLE 6.1 – Flanged Longitudinals and Flanged Brackets

Detail	Standard	Limit	Remarks
<p>Breadth of flange</p>  <p>compared to correct size</p>	<p>± 3 mm</p>	<p>± 5 mm</p>	
<p>Angle between flange and web</p>  <p>compared to template</p>	<p>± 3 mm</p>	<p>± 5 mm</p>	<p>per 100 mm of a</p>
<p>Straightness in plane of flange and web</p> 	<p>± 10 mm</p>	<p>± 25 mm</p>	<p>per 10 m</p>

TABLE 6.2 – Built Up Sections

Detail	Standard	Limit	Remarks
<p>Frames and longitudinal</p> 	<p>$\pm 1.5 \text{ mm}$</p>	<p>$\pm 3 \text{ mm}$</p>	<p>per 100 mm of a</p>
<p>Distortion of face plate</p> 	<p>$d \leq 3 + a/100 \text{ mm}$</p>	<p>$d \leq 5 + a/100 \text{ mm}$</p>	
<p>Distortion in plane of web and flange of built up longitudinal frame, transverse frame, girder and transverse web.</p> 	<p>$\pm 10 \text{ mm}$</p>	<p>$\pm 25 \text{ mm}$</p>	<p>per 10 m in length</p>

TABLE 6.3 – Corrugated Bulkheads

Detail	Standard	Limit	Remarks
<p>Mechanical bending</p> 	$R \geq 3t \text{ mm}$	$2t \text{ mm}$	<p>Material to be suitable for cold flanging (forming) and welding in way of radius</p>
<p>Depth of corrugation</p> 	$\pm 3 \text{ mm}$	$\pm 6 \text{ mm}$	
<p>Breadth of corrugation</p> 	$\pm 3 \text{ mm}$	$\pm 6 \text{ mm}$	
<p>Pitch and depth of swedged corrugated bulkhead compared with correct value</p> 	<p>$h : \pm 2.5 \text{ mm}$</p> <p>Where it is not aligned with other bulkheads $P : \pm 6 \text{ mm}$</p> <p>Where it is aligned with other bulkheads $P : \pm 2 \text{ mm}$</p>	<p>$h : \pm 5 \text{ mm}$</p> <p>Where it is not aligned with other bulkheads $P : \pm 9 \text{ mm}$</p> <p>Where it is aligned with other bulkheads $P : \pm 3 \text{ mm}$</p>	

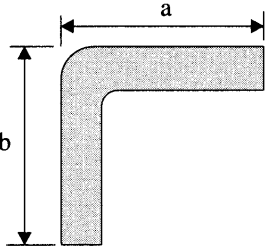
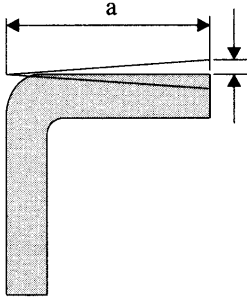
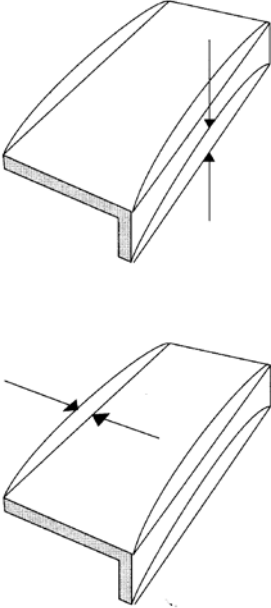
TABLE 6.4 – Pillars, Brackets and Stiffeners

Detail	Standard	Limit	Remarks
<p>Pillar (between decks)</p> 	<p>4 mm</p>	<p>6 mm</p>	
<p>Cylindrical structure diameter (pillars, masts, posts, etc.)</p> 	<p>$\pm D/200$ mm max. + 5 mm</p>	<p>$\pm D/150$ mm max. 7.5 mm</p>	
<p>Tripping bracket and small stiffener, distortion at the part of free edge</p> 	<p>$a \leq t/2$ mm</p>	<p>t</p>	
<p>Ovality of cylindrical structure</p> 		<p>$d_{\max} - d_{\min} \leq 0.02 \times d_{\max}$</p>	

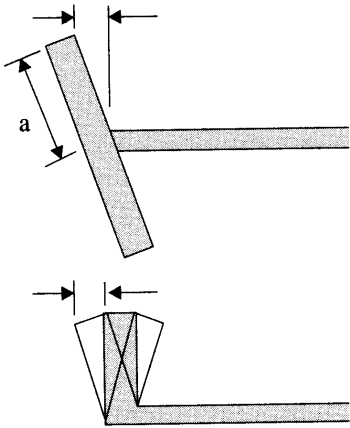
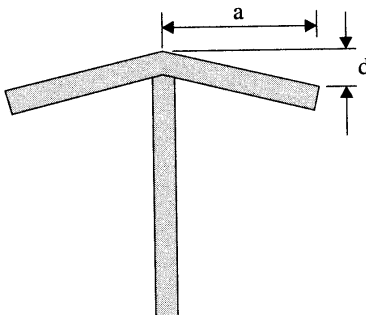
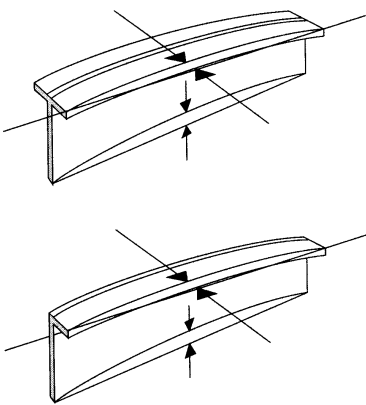
TABLE 6.5 – Maximum Heating Temperature on Surface for Line Heating

Item		Standard	Limit	Remarks
Conventional Process AH32-EH32 & AH36-EH36 TMCP type AH32-EH32 & AH36-EH36 (Ceq.>0.38%)	Water cooling just after heating	Under 650°C		
	Air cooling after heating	Under 900°C		
	Air cooling and subsequent water cooling after heating	Under 900°C (starting temperature of water cooling to be under 500°C)		
TMCP type AH32-DH32 & AH36-DH36 (Ceq. ≤ 0.38%)	Water cooling just after heating or air cooling	Under 1000°C		
TMCP type EH32 & EH36 (Ceq. ≤ 0.38%)	Water cooling just after heating or air cooling	Under 900°C		

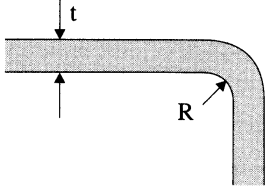
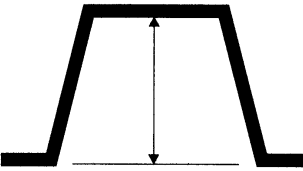
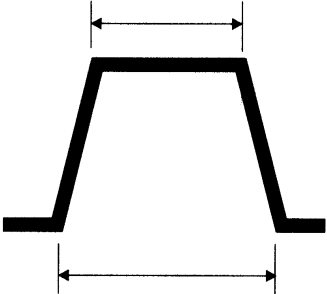
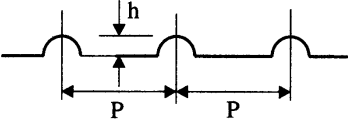
NOTE:

$$Ceq = C + \frac{Mn}{6} + \frac{Cr + Mo + V}{5} + \frac{Ni + Cu}{15} (\%)$$

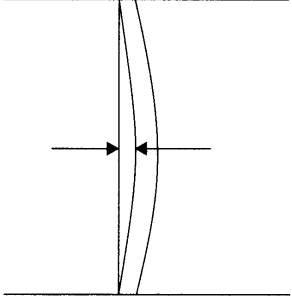
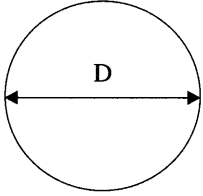
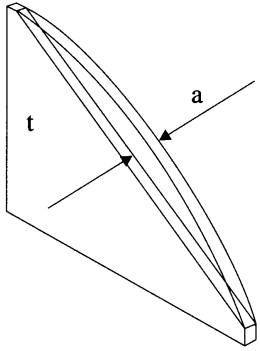
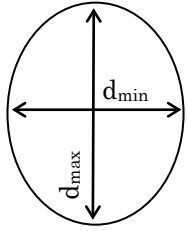
TABLE 6.6 – Block Assembly

Item	Standard	Limit	Remarks
Flat Plate Assembly			
Length and Breadth	± 4 mm	± 6 mm	
Distortion	± 10 mm	±20mm	
Squareness	± 5 mm	±10mm	
Deviation of interior members from plate	5 mm	10mm	
Curved plate assembly			
Length and Breadth	± 4 mm	± 8 mm	measured along the girth
Distortion	± 10 mm	± 20 mm	
Squareness	± 10 mm	± 15 mm	
Deviation of interior members from plate	5 mm	10 mm	
Flat cubic assembly			
Length and Breadth	± 4 mm	± 6 mm	
Distortion	± 10 mm	± 20 mm	
Squareness	± 5 mm	± 10 mm	
Deviation of interior members from plate	5 mm	10 mm	
Twist	± 10 mm	± 20 mm	
Deviation between upper and lower plate	± 5 mm	± 10 mm	
Curved cubic assembly			
Length and Breadth	± 4 mm	± 8 mm	measured along with girth
Distortion	± 10 mm	± 20 mm	
Squareness	± 10 mm	± 15 mm	
Deviation of interior members from plate	± 5 mm	± 10 mm	
Twist	± 15 mm	± 25 mm	
Deviation between upper and lower plate	± 7 mm	± 15 mm	

TABLE 6.7 – Special Sub-Assembly

Item	Standard	Limit	Remarks
Distance between upper/lower gudgeon	± 5 mm	± 10 mm	
Distance between aft edge of boss and aft peak bulkhead	± 5 mm	± 10 mm	
Twist of sub-assembly of stern frame	5 mm	10 mm	
Deviation of rudder from shaft center line	4 mm	8 mm	
Twist of rudder plate	6 mm	10 mm	
Flatness of top plate of main engine bed	5 mm	10 mm	
Breadth and length of top plate of main engine bed	± 4 mm	± 6 mm	

NOTE:

Dimensions and tolerances have to fulfill engine and equipment manufacturers' requirements, if any.

TABLE 6.8 – Shape

Detail	Standard	Limit	Remarks
Deformation for the whole length 	$\pm 50 \text{ mm}$		per 100 m against the line of keel sighting
Deformation for the distance between two adjacent bulkheads 	$\pm 15 \text{ mm}$		
Cocking-up of fore body 	$\pm 30 \text{ mm}$		The deviation is to be measured from the design line.
Cocking-up of aft-body 	$\pm 20 \text{ mm}$		
Rise of floor amidships 	$\pm 15 \text{ mm}$		The deviation is to be measured from the design line.

TABLE 6.9 – Shape

Item	Standard	Limit	Remarks
Length between perpendiculars	$\pm L/1000$ mm where L is in mm		Applied to ships of 100 metre length and above. For the convenience of the measurement the point where the keel is connected to the curve of the stem may be substituted for the fore perpendicular in the measurement of the length.
Moulded breadth at midship	$\pm B/1000$ mm where B is in mm		Applied to ships of 15 metre breadth and above, measured on the upper deck.
Moulded depth at midship	$\pm D/1000$ mm where D is in mm		Applied to ships of 10 metre depth and above, measured up to the upper deck.

TABLE 6.10 – Fairness of Plating Between Frames

Item		Standard	Limit	Remarks
Shell plate	Parallel part (side & bottom shell)	4 mm	8 mm	
	Fore and aft part	5 mm		
Tank top plate	4 mm			
Bulkhead	Longl. Bulkhead Trans. Bulkhead Swash Bulkhead	6 mm		
Strength deck	Parallel part	4 mm	8 mm	
	Fore and aft part	6 mm	9 mm	
	Covered part	7 mm	9 mm	
Second deck	Bare part	6 mm	8 mm	
	Covered part	7 mm	9 mm	
Forecastle deck poop deck	Bare part	4 mm	8 mm	
	Covered part	6 mm	9 mm	
Super structure deck	Bare part	4 mm	6 mm	
	Covered part	7 mm	9 mm	
House wall	Outside wall	4 mm	6 mm	
	Inside wall	6 mm	8 mm	
	Covered part	7 mm	9 mm	
Interior member (web of girder, etc)		5 mm	7 mm	
Floor and girder in double bottom		5 mm	8 mm	

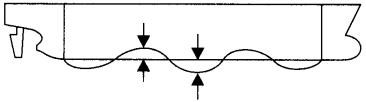
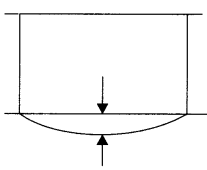
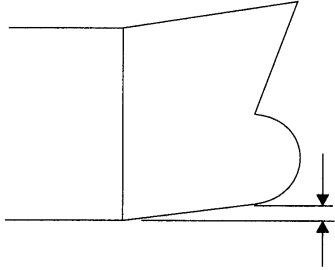
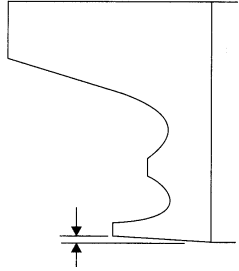
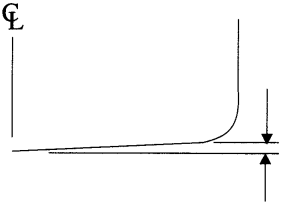
TABLE 6.11 – Fairness of Plating with Frames

Item		Standard	Limit	Remarks
Shell plate	Parallel part	$\pm 2 l / 1000$ mm	$\pm 3 l / 1000$ mm	$l =$ span of frame (mm) To be measured between on trans. space (min. $l = 3000$ mm)
	Fore and aft part	$\pm 3 l / 1000$ mm	$\pm 4 l / 1000$ mm	
Strength deck (excluding cross deck) and top plate of double bottom	-	$\pm 3 l / 1000$ mm	$\pm 4 l / 1000$ mm	
Bulkhead	-		$\pm 5 l / 1000$ mm	
Accommodation above the strength deck and others	-	$\pm 5 l / 1000$ mm	$\pm 6 l / 1000$ mm	
 <p> l mm $l =$ span of frame (minimum $l = 3000$ mm) </p> <p>To be measured between one trans. space.</p>				

TABLE 6.12 – Preheating for welding hull steels at low temperature

Item		Standard		Limit	Remarks
		Base metal temperature needed preheating	Minimum preheating temperature		
Normal strength steels	A, B, D, E	Below -5 °C	20 °C ¹⁾		
Higher strength steels (TMCP type)	AH32 – EH32 AH36 – EH36	Below 0 °C			
Higher strength steels (Conventional type)		Below 0 °C			

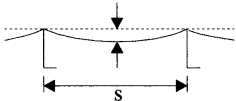
(Note)

- 1) This level of preheat is to be applied unless the approved welding procedure specifies a higher level.

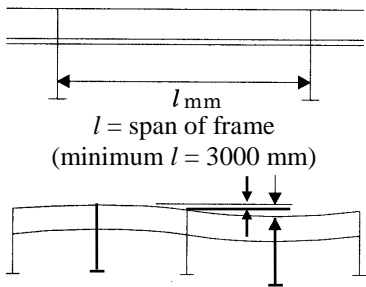
TABLE 7.1 – Alignment

Detail	Standard	Limit	Remarks
<p>Alignment of butt welds</p> 		<p>$a \leq 0.15t$ strength member $a \leq 0.2t$ other but maximum 4.0 mm</p>	<p>t is the lesser plate thickness</p>
<p>Alignment of fillet welds</p>  <p style="text-align: center;">$t_1 < t_2$</p>		<p>Strength member and higher stress member: $a \leq t_1/3$</p> <p>Other: $a \leq t_1/2$</p>	<p>Alternatively, heel line can be used to check the alignment.</p> <p>Where t_3 is less than t_1, then t_3 should be substituted for t_1 in the standard.</p>
<p>Alignment of fillet welds</p> 		<p>Strength member and higher stress member: $a \leq t_1/3$</p> <p>Other: $a \leq t_1/2$</p>	<p>Alternatively, heel line can be used to check the alignment.</p> <p>Where t_3 is less than t_1, then t_3 should be substitute for t_1 in the standard.</p>

TABLE 7.2 – Alignment

Detail	Standard	Limit	Remarks
<p>Alignment of flange of T-longitudinal</p> 	<p>Strength member $a \leq 0.04b$ (mm)</p>	<p>$a = 8.0$ mm</p>	
<p>Alignment of height of T-bar, L-angle bar or bulb</p> 	<p>Strength member $a \leq 0.15t$ Other $a \leq 0.20t$</p>	<p>$a = 3.0$ mm</p>	
<p>Alignment of panel stiffener</p> 	<p>$d \leq L/50$</p>		
<p>Gap between bracket/intercostal and stiffener</p> 	<p>$a \leq 2.0$ mm</p>	<p>$a = 3.0$ mm</p>	
<p>Alignment of lap welds</p> 	<p>$a \leq 2.0$ mm</p>	<p>$a = 3.0$ mm</p>	

TABLE 7.3 – Alignment

Detail	Standard	Limit	Remarks
<p>Gap between beam and frame</p>  <p>The diagram shows a cross-section of a beam (top horizontal line) and a frame (bottom vertical line). A gap 'a' is indicated between the bottom flange of the beam and the top flange of the frame. A dashed line shows the intended alignment.</p>	$a \leq 2.0 \text{ mm}$	$a = 5.0 \text{ mm}$	
<p>Gap around stiffener cut-out</p>  <p>The diagram shows two stiffener cut-outs on a plate. The left cut-out is a vertical stiffener, and the right is a horizontal stiffener. Gaps 's' are indicated between the stiffener and the plate. A dashed box encloses the two cut-outs.</p>	$s \leq 2.0 \text{ mm}$	$s = 3.0 \text{ mm}$	

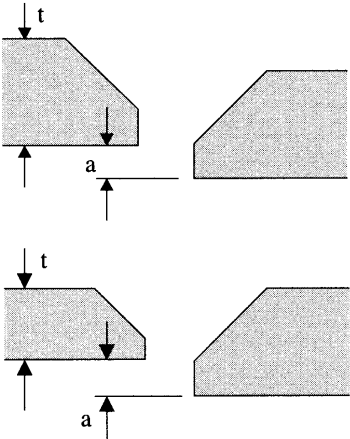
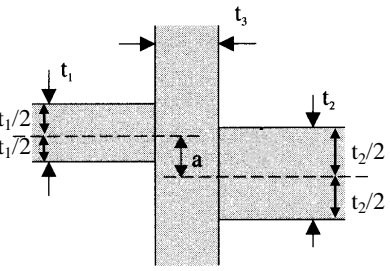
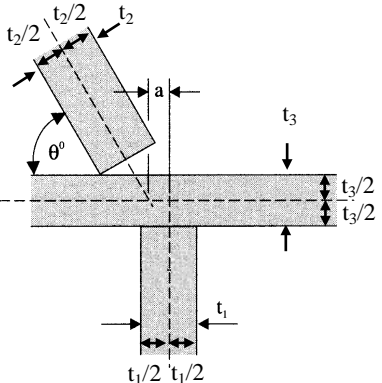
TABLE 8.1 – Typical Butt Weld Plate Edge Preparation (Manual Welding and Semi-Automatic Welding) for Reference

Detail	Standard	Limit	Remarks
Square butt $t \leq 5$ mm 	$G \leq 3$ mm	$G = 5$ mm	see Note 1
Single bevel butt $t > 5$ mm 	$G \leq 3$ mm	$G = 5$ mm	see Note 1
Double bevel butt $t > 19$ mm 	$G \leq 3$ mm	$G = 5$ mm	see Note 1
Double vee butt, uniform bevels 	$G \leq 3$ mm	$G = 5$ mm	see Note 1
Double vee butt, non-uniform bevel 	$G \leq 3$ mm	$G = 5$ mm	see Note 1
<p>NOTE 1</p> <p>Different plate edge preparation may be accepted or approved by the Classification Society in accordance with URW28 or other recognized standard accepted by the Classification Society. For welding procedures other than manual welding, see paragraph 3.2 Qualification of weld procedures.</p>			

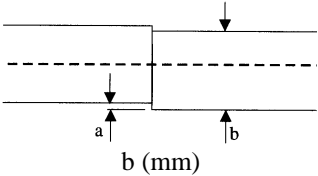
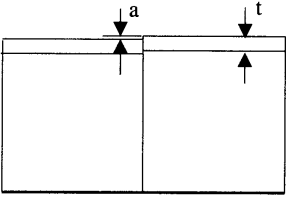
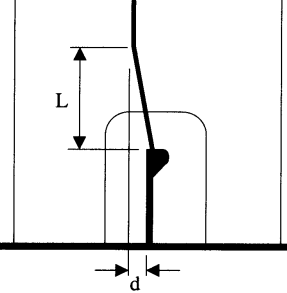
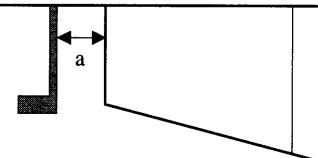
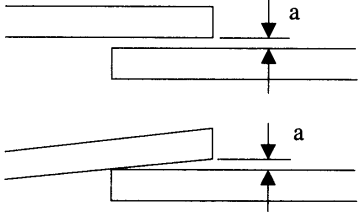
TABLE 8.2 – Typical Butt Weld Plate Edge Preparation (Manual Welding and Semi-Automatic Welding) for Reference

Detail	Standard	Limit	Remarks
<p>Single Vee butt, one side welding with backing strip (temporary or permanent)</p> 	<p>$G = 3 \text{ to } 9 \text{ mm}$</p>	<p>$G = 16 \text{ mm}$</p>	<p>see Note 1</p>
<p>Single vee butt</p> 	<p>$G \leq 3 \text{ mm}$</p>	<p>$G = 5 \text{ mm}$</p>	<p>see Note 1</p>
<p>NOTE 1</p> <p>Different plate edge preparation may be accepted or approved by the Classification Society in accordance with URW28 or other recognized standard accepted by the Classification Society. For welding procedures other than manual welding, see paragraph 3.2 Qualification of welding procedures.</p>			

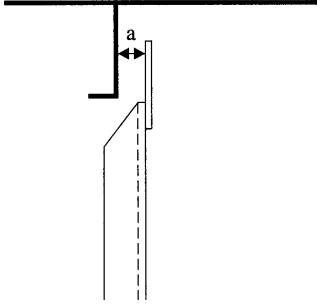
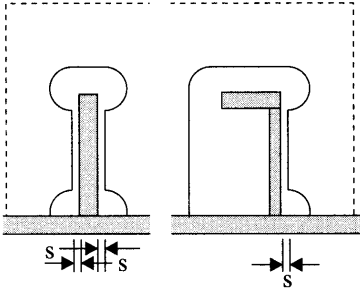
Table 8.3 – Typical Fillet Weld Plate Edge Preparation (Manual Welding and Semi-Automatic Welding) for Reference

Detail	Standard	Limit	Remarks
<p>Tee Fillet</p> 	$G \leq 2 \text{ mm}$	$G = 3 \text{ mm}$	see Note 1
<p>Inclined fillet</p> 	$G \leq 2 \text{ mm}$	$G = 3 \text{ mm}$	see Note 1
<p>Single bevel tee with permanent backing</p> 	$G \leq 4 \text{ to } 6 \text{ mm}$ $\theta^\circ = 30^\circ \text{ to } 45^\circ$	$G = 16 \text{ mm}$	Not normally for strength member also see Note 1
<p>Single bevel tee</p> 	$G \leq 3 \text{ mm}$		see Note 1
<p>NOTE 1</p> <p>Different plate edge preparation may be accepted or approved by the Classification Society in accordance with URW28 or other recognized standard accepted by the Classification Society. For welding procedures other than manual welding, see paragraph 3.2 Qualification of welding procedures.</p>			

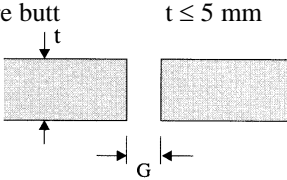
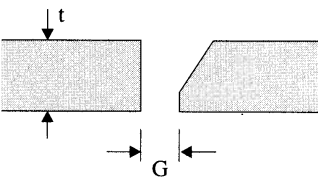
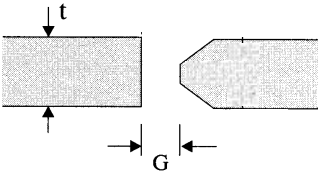
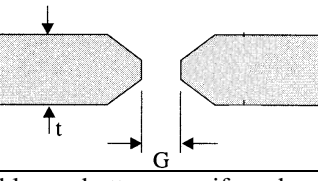
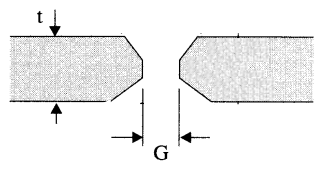
Table 8.4 – Typical Fillet Weld Plate Edge Preparation (Manual Welding and Semi-Automatic Welding) for Reference

Detail	Standard	Limit	Remarks
<p>Single 'J' bevel tee</p> 	<p>$G = 2.5 \text{ to } 4 \text{ mm}$</p>		<p>see Note 1</p>
<p>Double bevel tee symmetrical $t > 19 \text{ mm}$</p> 	<p>$G \leq 3 \text{ mm}$</p>		<p>see Note 1</p>
<p>Double bevel tee asymmetrical $t > 19 \text{ mm}$</p> 	<p>$G \leq 3 \text{ mm}$</p>		<p>see Note 1</p>
<p>Double 'J' bevel tee symmetrical</p> 	<p>$G = 2.5 \text{ to } 4 \text{ mm}$</p>		<p>see Note 1</p>

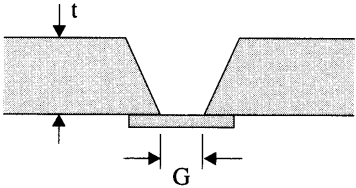
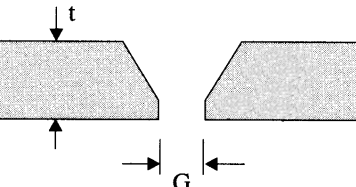
NOTE 1

Different plate edge preparation may be accepted or approved by the Classification Society in accordance with URW28 or other recognized standard accepted by the Classification Society.
 For welding procedures other than manual welding, see paragraph 3.2 Qualification of welding procedures.

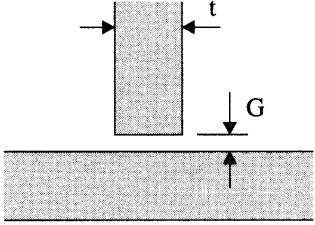
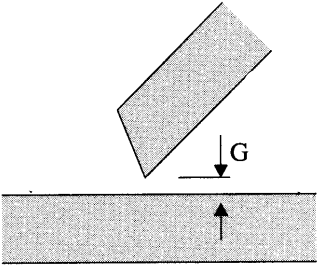
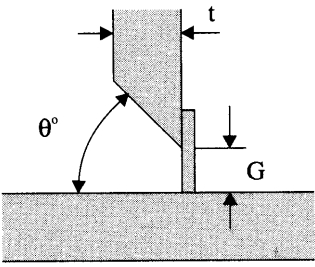
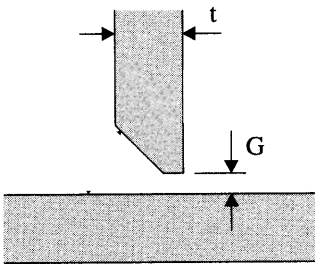
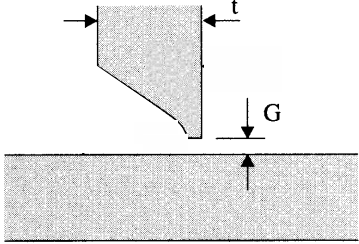
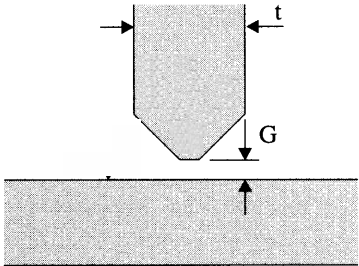
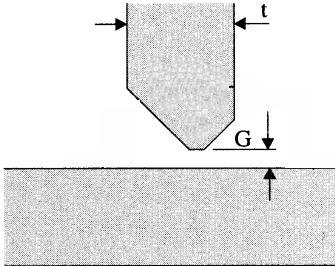
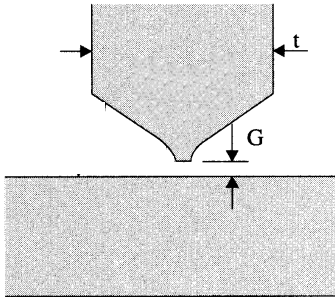
Table 8.5 – Butt And Fillet Weld Profile (Manual Welding and Semi-Automatic Welding)

Detail	Standard	Limit	Remarks
<p>Butt weld toe angle</p> 	$\theta \leq 60^\circ$ $h \leq 6 \text{ mm}$	$\theta \leq 90^\circ$	
<p>Butt weld undercut</p> 		$D \leq 0.5 \text{ mm}$ for strength member $D \leq 0.8 \text{ mm}$ for other	
<p>Fillet weld leg length</p>  <p>$s = \text{leg length}; a = \text{throat thickness}$</p>		$s \geq 0.9s_d$ $a \geq 0.9a_d$ over short weld lengths	$s_d = \text{design } s$ $a_d = \text{design } a$
<p>Fillet weld toe angle</p> 		$\theta \leq 90^\circ$	In areas of stress concentration and fatigue, the Classification Society may require a lesser angle.
<p>Fillet weld undercut</p> 		$D \leq 0.8 \text{ mm}$	

Table 8.6 – Typical Butt Weld Plate Edge Preparation (Automatic welding) for Reference

Detail	Standard	Limit	Remarks
<p>Submerged Arc Welding (SAW)</p> 	$0 \leq G \leq 0.8 \text{ mm}$	$G = 2 \text{ mm}$	See Note 1.
<p>NOTE 1</p> <p>Different plate edge preparation may be accepted or approved by the Classification Society in accordance with URW28 or other recognized standard accepted by the Classification Society. For welding procedures other than manual welding, see paragraph 3.2 Qualification of welding procedures.</p>			

Table 8.7 – Distance Between Welds

Detail	Standard	Limit	Remarks
<p>Scallops over weld seams</p> 		<p>for strength member $d \geq 5\text{mm}$</p> <p>for other $d \geq 0\text{mm}$</p>	<p>The “d” is to be measured from the toe of the fillet weld to the toe of the butt weld.</p>
<p>Distance between two butt welds</p> 		<p>$d \geq 0\text{ mm}$</p>	
<p>Distance between butt weld and fillet weld</p> 		<p>for strength member $d \geq 10\text{ mm}$</p> <p>for other $d \geq 0\text{ mm}$</p>	<p>The “d” is to be measured from the toe of the fillet weld to the toe of the butt weld.</p>
<p>Distance between butt welds</p> 	<p>for cut-outs $d \geq 30\text{ mm}$</p>		
	<p>for margin plates $d \geq 300\text{ mm}$</p>	<p>150 mm</p>	

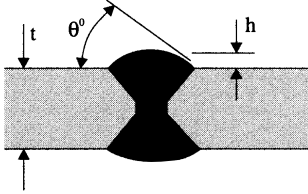
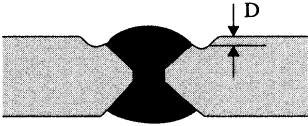
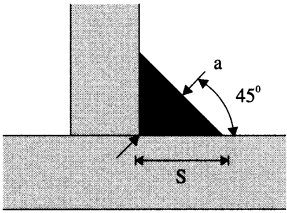
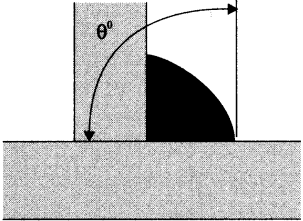
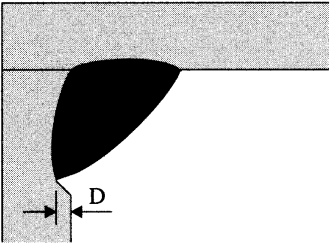
Table 9.1 – Typical Misalignment Remedial

Detail	Remedial Standard	Remarks
<p>Alignment of butt joints</p> 	<p>Strength member $a > 0.15t_1$ or $a > 4$ mm release and adjust</p> <p>Other $a > 0.2t_1$ or $a > 4$ mm release and adjust</p>	<p>t_1 is lesser plate thickness</p>
<p>Alignment of fillet welds</p>  <p style="text-align: center;">$t_1 < t_2$</p>	<p>Strength member and higher stress member $t_1/3 < a \leq t_1/2$ - generally increase weld throat by 10%</p> <p>$a > t_1/2$ - release and adjust over a minimum of 50a</p> <p>Other $a > t_1/2$ - release and adjust over a minimum of 30a</p>	<p>Alternatively, heel line can be used to check the alignment.</p> <p>Where t_3 is less than t_1 then t_3 should be substituted for t_1 in standard</p>
<p>Alignment of flange of T-longitudinal</p> 	<p>When $0.04b < a \leq 0.08b$, max 8 mm: grind corners to smooth taper over a minimum distance $L = 3a$</p> <p>When $a > 0.08b$ or 8 mm: grind corners to smooth taper over a minimum distance $L = 50a$</p>	
<p>Alignment of height of T-bar, L-angle bar or bulb</p> 	<p>When $3 \text{ mm} < a \leq 6 \text{ mm}$: build up by welding</p> <p>When $a > 6 \text{ mm}$: release and adjust over minimum $L = 50a$ for strength member and $L = 30a$ for other</p> 	
<p>Alignment of lap welds</p> 	<p>$3 \text{ mm} < a \leq 5 \text{ mm}$: weld leg length to be increased by the same amount as increase in gap in excess of 3 mm</p> <p>$a > 5 \text{ mm}$: members to be re-aligned</p>	

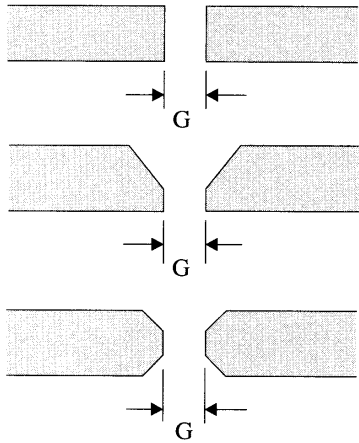
Table 9.2 – Typical Misalignment Remedial

Detail	Remedial Standard	Remarks
<p>Gap between bracket/intercostal and stiffener</p> 	<p>When $3 \text{ mm} < a \leq 5 \text{ mm}$: weld leg length to be increased by increase in gap in excess of 3 mm</p> <hr/> <p>When $5 \text{ mm} < a \leq 10 \text{ mm}$: chamfer 30° to 40° and build up by welding with backing</p> <hr/> <p>When $a > 10 \text{ mm}$: increase gap to about 50 mm and fit collar plate</p>  <p>$t \geq t_1$</p> <p>$b = (2t + 25) \text{ mm, min. } 50 \text{ mm}$</p>	
<p>Gap between beam and frame</p> 	<p>$3 \text{ mm} < a \leq 5 \text{ mm}$: weld leg length to be increased by the same amount as increase in gap in excess of 3 mm</p> <p>$a > 5 \text{ mm}$ release and adjust</p>	

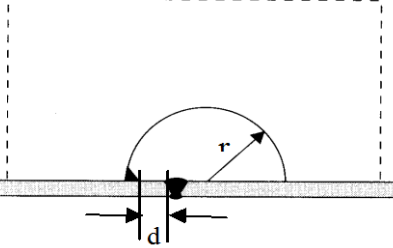
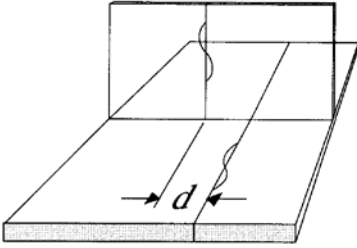
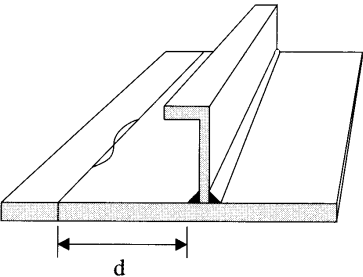
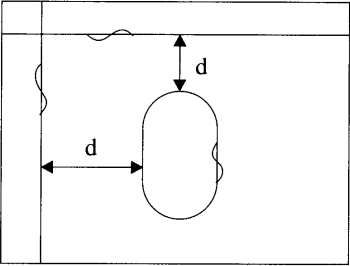
TABLE 9.3 – Misalignment Remedial

Detail	Remedial standard	Remarks
<p>Position of scallop</p> 	<p>When $d < 75 \text{ mm}$ web plate to be cut between scallop and slot, and collar plate to be fitted</p>  <p>$b \text{ (min. 50mm)}$</p> <p>Or fit small collar over scallop</p>  <p>Or fit collar plate over scallop</p> 	
<p>Gap around stiffener cut-out</p> 	<p>When $3 \text{ mm} < s \leq 5 \text{ mm}$ weld leg length to be increased by the same amount as increase in gap in excess of 2 mm</p> <hr/> <p>When $5 \text{ mm} < s \leq 10 \text{ mm}$ nib to be chamfered and built up by welding</p> <hr/> <p>When $s > 10 \text{ mm}$ cut off nib and fit collar plate of same height as nib</p>  <p>$20 \text{ mm} \leq b \leq 50 \text{ mm}$</p>	

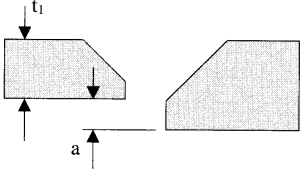
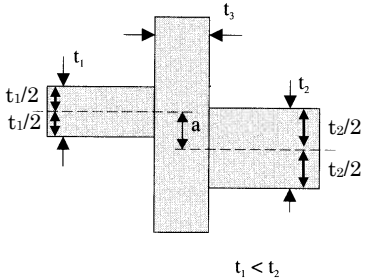
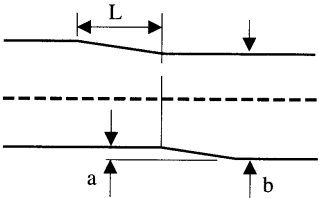
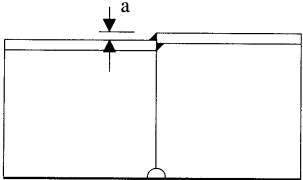
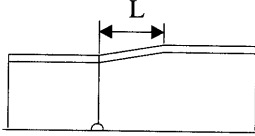
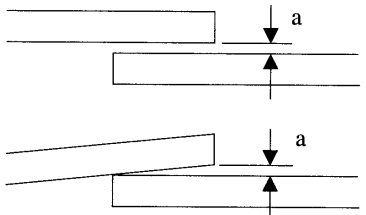
TABLE 9.4 – Typical Butt Weld Plate Edge Preparation Remedial (Manual Welding and Semi-Automatic Welding)

Detail	Remedial standard	Remarks
<p>Square butt</p> 	<p>When $G \leq 10$ mm chamfer to 45° and build up by welding</p> <p>When $G > 10$mm build up with backing strip; remove, back gouge and seal weld; or, insert plate, min. width 300 mm</p>	
<p>Single bevel butt</p> 	<p>When $5 \text{ mm} < G \leq 1.5t$ (maximum 25 mm) build up gap with welding on one or both edges to maximum of $0.5t$, using backing strip, if necessary.</p> <p>Where a backing strip is used, the backing strip is to be removed, the weld back gouged, and a sealing weld made.</p> 	
<p>Double bevel butt</p> 	<p>Different welding arrangement by using backing material approved by the Classification Society may be accepted on the basis of an appropriate welding procedure specification.</p> <p>When $G > 25$ mm or $1.5t$, whichever is smaller, use insert plate, of minimum width 300 mm</p>	
<p>Double vee butt, uniform bevels</p> 		
<p>Double vee butt, non-uniform bevel</p> 		

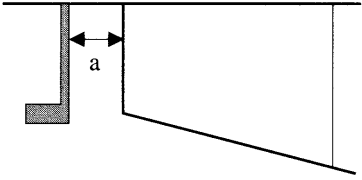
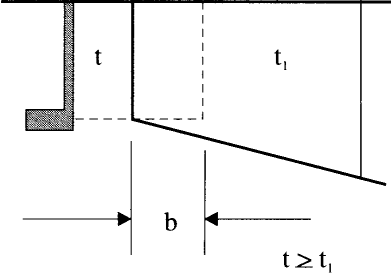
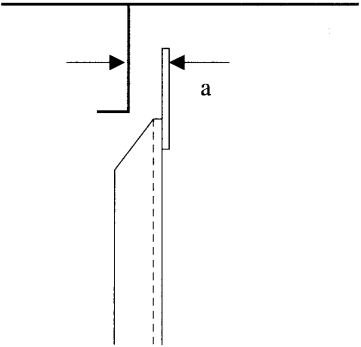
TABLE 9.5 – Typical Butt Weld Plate Edge Preparation Remedial (Manual Welding and Semi-Automatic Welding)

Detail	Remedial Standard	Remarks
<p>Single vee butt, one side welding</p> 	<p>When $5 \text{ mm} < G \leq 1.5t \text{ mm}$ (maximum 25 mm), build up gap with welding on one or both edges, to “Limit” gap size preferably to “Standard” gap size as described in Table 8.2.</p> <p>Where a backing strip is used, the backing strip is to be removed, the weld back gouged, and a sealing weld made.</p> <p>Different welding arrangement by using backing material approved by the Classification Society may be accepted on the basis of an appropriate welding procedure specification.</p>	
<p>Single vee butt</p> 	 <p>Limits see Table 8.2</p> <p>When $G > 25 \text{ mm}$ or $1.5t$, whichever is smaller, use insert plate of minimum width 300 mm.</p>  <p>Min. 300 mm</p>	

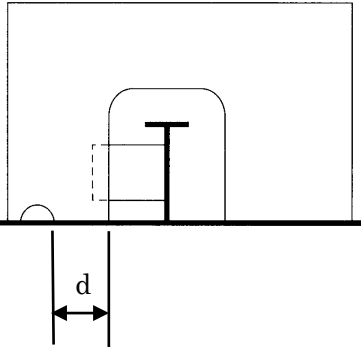
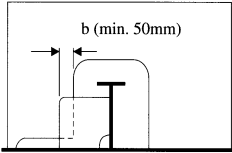
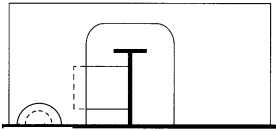
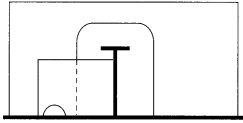
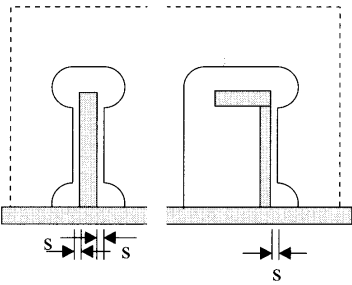
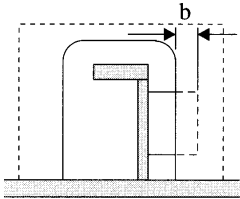
TABLE 9.6 – Typical Fillet Weld Plate Edge Preparation Remedial (Manual Welding and Semi-Automatic Welding)

Detail	Remedial standard	Remarks
<p>Tee Fillet</p> 	<p>3 mm < G ≤ 5 mm – leg length increased to Rule leg + (G-2)</p> <p>5 mm < G ≤ 16 mm or G ≤ 1.5t - chamfer by 30° to 45°, build up with welding, on one side, with backing strip if necessary, grind and weld.</p>  <p>30° to 45°</p> <p>G > 16 mm or G > 1.5t use insert plate of minimum width 300 mm</p>  <p>300 mm minimum</p>	
<p>Liner treatment</p> 	<p>$t_2 \leq t \leq t_1$ $G \leq 2 \text{ mm}$ $a = 5 \text{ mm} + \text{fillet leg length}$</p>	<p>Not to be used in cargo area or areas of tensile stress through the thickness of the liner</p>

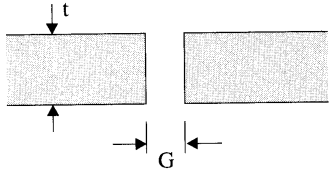
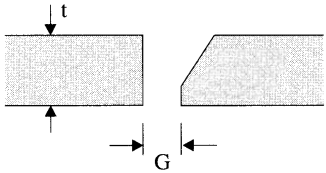
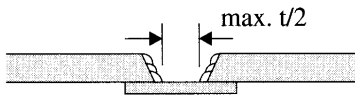
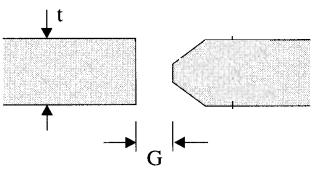
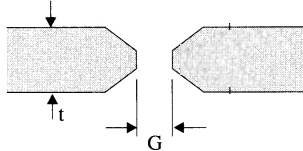
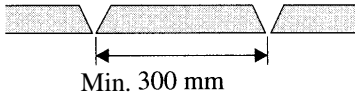
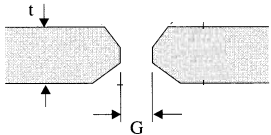
TABLE 9.7 – Typical Fillet Weld Plate Edge Preparation Remedial (Manual Welding and Semi-Automatic Welding)

Detail	Remedial standard	Remarks
<p>Single bevel tee</p> 	<p>3 mm < G ≤ 5 mm build up weld</p> <hr/> <p>5 mm < G ≤ 16 mm - build up with welding, with backing strip if necessary, remove backing strip if used, back gouge and back weld.</p>  <hr/> <p>G > 16 mm new plate to be inserted of minimum width 300 mm</p> 	

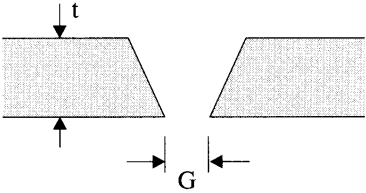
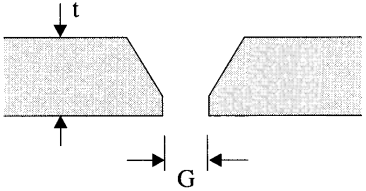
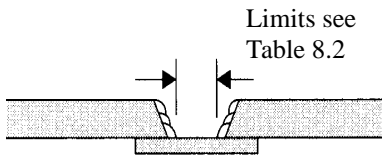
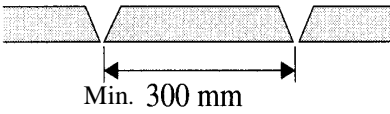
TABLE 9.8 – Typical Fillet Weld Plate Edge Preparation Remedial (Manual Welding and Semi-Automatic Welding)

Detail	Remedial standard	Remarks
<p>Single 'J' bevel tee</p> 	<p>as single bevel tee</p>	
<p>Double bevel tee symmetrical</p> 	<p>When $5 \text{ mm} < G \leq 16 \text{ mm}$ build up with welding using ceramic or other approved backing bar, remove, back gouge and back weld.</p> 	
<p>Double bevel tee asymmetrical</p> 	<p>When $G > 16 \text{ mm}$-insert plate of minimum height 300 mm to be fitted.</p> 	
<p>Double 'J' bevel symmetrical</p> 		

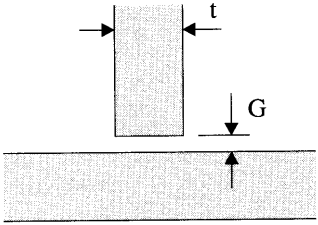
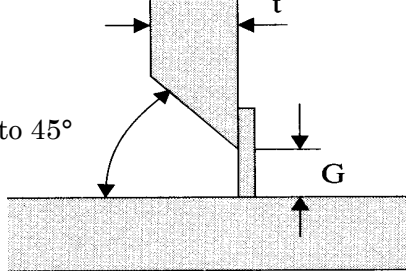
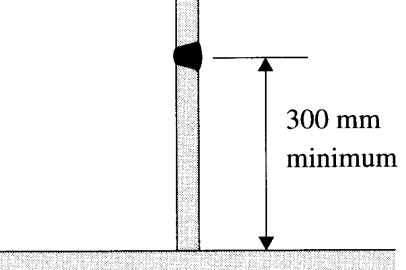
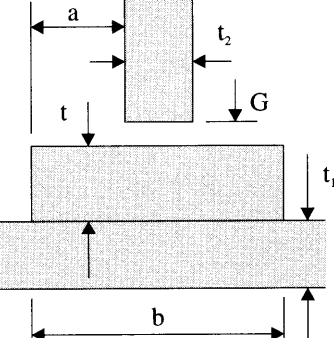
TABLE 9.9 – Typical Fillet and Butt Weld Profile Remedial (Manual Welding and Semi-Automatic Welding)

Detail	Remedial standard	Remarks
<p>Fillet weld leg length</p> 	<p>Increase leg or throat by welding over</p>	<p>Minimum short bead to be referred Table 9.14</p>
<p>Fillet weld toe angle</p> 	<p>$\theta > 90^\circ$ grinding, and welding, where necessary, to make $\theta \leq 90^\circ$</p>	
<p>Butt weld toe angle</p> 	<p>$\theta > 90^\circ$ grinding, and welding, where necessary, to make $\theta \leq 90^\circ$</p>	
<p>Butt weld undercut</p> 	<p>For strength member, where $0.5 < D \leq 1$ mm, and for other, where $0.8 < D \leq 1$ mm, undercut to be ground smooth (localized only) or to be filled by welding</p> <p>Where $D > 1$ mm undercut to be filled by welding</p>	
<p>Fillet weld undercut</p> 	<p>Where $0.8 < D \leq 1$ mm undercut to be ground smooth (localized only) or to be filled by welding</p> <p>Where $D > 1$ mm undercut to be filled by welding</p>	

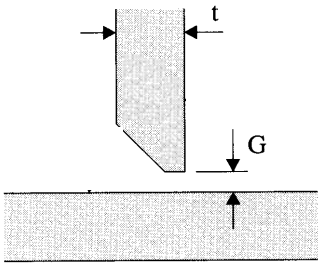
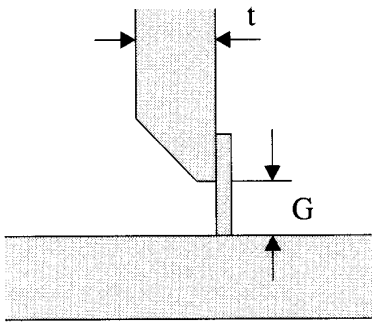
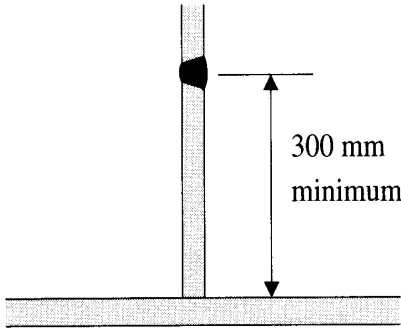
TABLE 9.10 – Distance Between Welds Remedial

Detail	Remedial standard	Remarks
<p data-bbox="177 409 456 439">Scallops over weld seams</p> 	<p data-bbox="679 562 1075 622">Hole to be cut and ground smooth to obtain distance</p>	

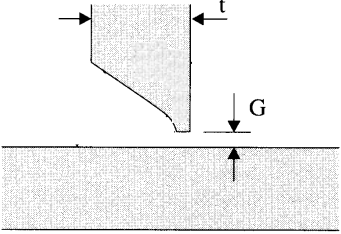
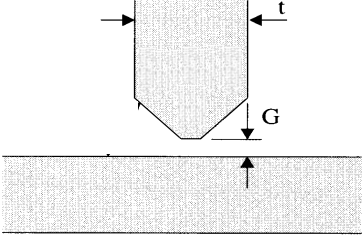
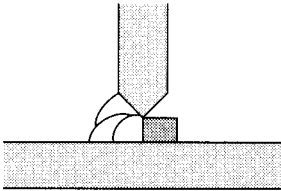
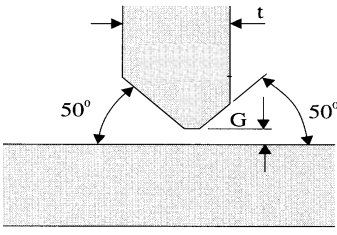
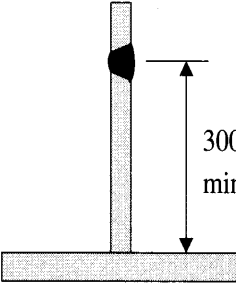
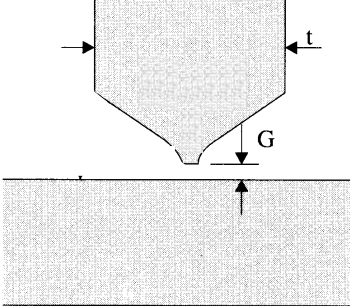
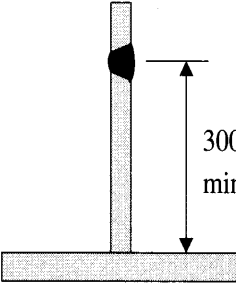
TABLE 9.11 – Erroneous Hole Remedial

Detail	Remedial standard	Remarks
<p>Holes made erroneously $D < 200$ mm</p> 	<p>Strength member open hole to minimum 75 mm dia., fit and weld spigot piece</p>  <p>$\theta = 30 - 40^\circ$ $G = 4 - 6$ mm $1/2t \leq t_1 \leq t$ $l = 50$ mm</p> <p>Or open hole to over 300 mm and fit insert plate</p>	<p>Fillet weld to be made after butt weld</p> <p>The fitting of spigot pieces in areas of high stress concentration or fatigue is to be approved by the Classification Society.</p>
	<p>Other open hole to over 300 mm and fit insert plate</p> <p>Or fit lap plate</p>  <p>$t_1 = t_2$ $L = 50$ mm, min</p>	
<p>Holes made erroneously $D \geq 200$ mm</p> 	<p>Strength member open hole and fit insert plate</p> <p>Other open hole to over 300 mm and fit insert plate Or fit lap plate</p>  <p>$t_1 = t_2$ $L = 50$ mm, min</p>	

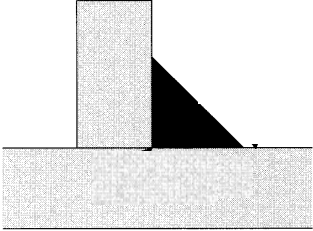
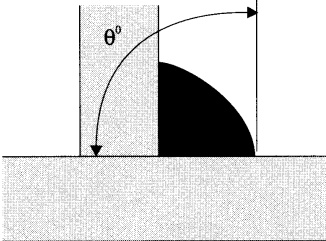
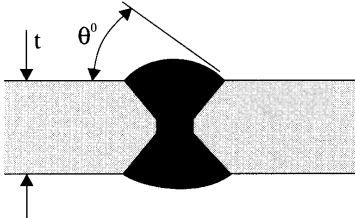
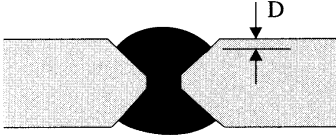
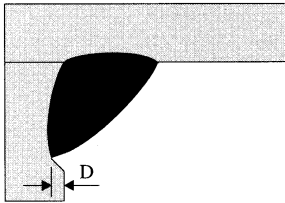
TABLE 9.12 – Remedial by Insert Plate

Detail	Remedial standard	Remarks
<p>Remedial by insert plate</p> 	<p> $L = 300 \text{ mm minimum}$ $B = 300 \text{ mm minimum}$ $R = 5t \text{ mm}$ 100mm minimum </p> <p>(1) seam with insert piece is to be welded first</p> <p>(2) original seam is to be released and welded over for a minimum of 100 mm.</p>	
<p>Remedial of built section by insert plate</p> 	<p> $L_{\min} \geq 300 \text{ mm}$ </p> <p>Welding sequence (1) → (2) → (3) → (4)</p> <p>Web butt weld scallop to be filled during final pass (4)</p>	

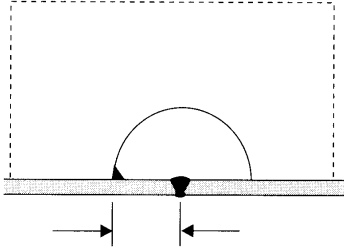
TABLE 9.13 – Weld Surface Remedial

Detail	Remedial standard	Remarks
<p>Weld spatter</p> 	<ol style="list-style-type: none"> 1. Remove spatter observed before blasting with scraper or chipping hammer, etc. 2. For spatter observed after blasting: <ol style="list-style-type: none"> a) Remove with a chipping hammer, scraper, etc. b) For spatter not easily removed with a chipping hammer, scraper, etc., grind the sharp angle of spatter to make it obtuse. 	<p>In principle, no grinding is applied to weld surface.</p>
<p>Arc strike (HT steel, Cast steel, Grade E of mild steel, TMCP type HT steel, Low temp steel)</p>	<p>Remove the hardened zone by grinding or other measures such as overlapped weld bead etc.</p>	<p>Minimum short bead to be referred Table 9.14</p>

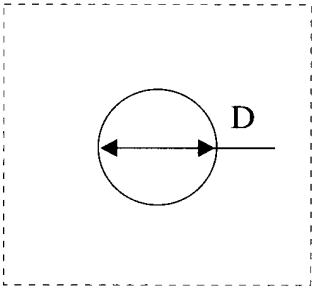
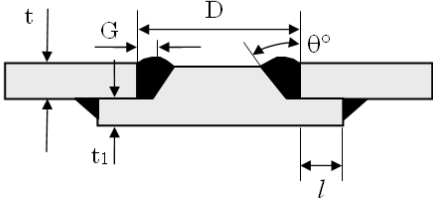
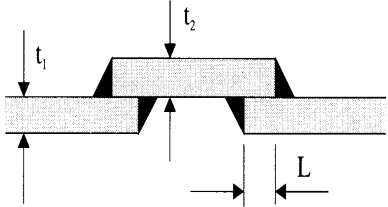
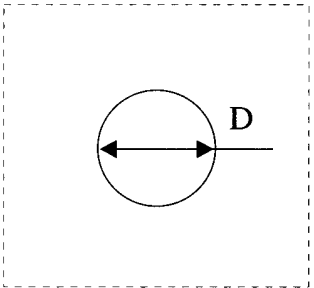
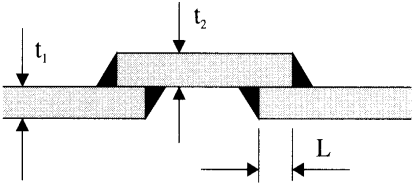
TABLE 9.14 – Welding Remedial by Short Bead

Detail	Remedial standard	Remarks
Short bead for remedying scar (scratch)	a) HT steel, Cast steel, TMCP type HT steel (Ceq > 0.36%) and Low temp steel (Ceq > 0.36%) Length of short bead ≥ 50 mm b) Grade E of mild steel Length of short bead ≥ 30 mm c) TMCP type HT steel (Ceq ≤ 0.36%) and Low temp steel (Ceq ≤ 0.36%) Length of short bead ≥ 10 mm	Preheating is necessary at 100 ± 25°C
Remedying weld bead	a) HT steel, Cast steel, TMCP type HT steel (Ceq > 0.36%) and Low temp steel (Ceq > 0.36%) Length of short bead ≥ 50 mm b) Grade E of mild steel Length of short bead ≥ 30 mm c) TMCP type HT steel (Ceq ≤ 0.36%) and Low temp steel (Ceq ≤ 0.36%) Length of short bead ≥ 30 mm	
<p>NOTE:</p> <p>1. When short bead is made erroneously, remove the bead by grinding.</p> <p>2. $Ceq = C + \frac{Mn}{6} + \frac{Cr + Mo + V}{5} + \frac{Ni + Cu}{15} (\%)$</p>		

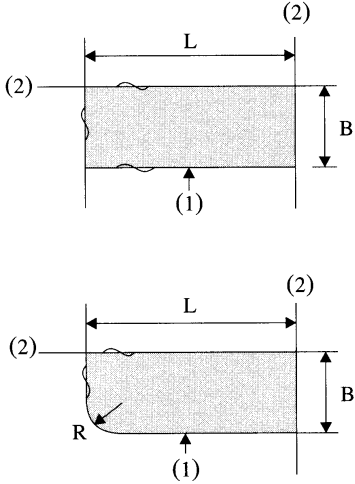
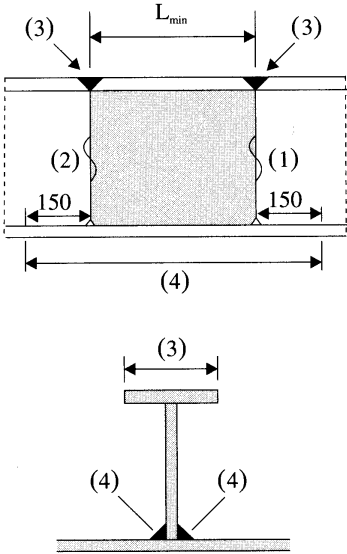
**No. Part B
47**

Repair Quality Standard for Existing Ships

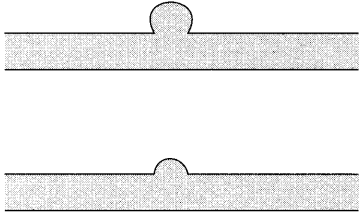
**No.
47**

(cont)

Part B - Shipbuilding and Repair Quality Standard for Existing Ships**CONTENTS:**

- 1. Scope**
- 2. General requirements to repairs and repairers**
- 3. Qualification of personnel**
 - 3.1 Qualification of welders
 - 3.2 Qualification of welding procedures
 - 3.3 Qualification of NDE operators
- 4. Materials**
 - 4.1 General requirements to materials
 - 4.2 Equivalency of material grades
- 5. General requirements to welding**
 - 5.1 Correlation of welding consumables to hull structural steels
 - 5.2 General requirements to preheating and drying out
 - 5.3 Dry welding on hull plating below the waterline of vessels afloat
- 6. Repair quality standard**
 - 6.1 Welding, general
 - 6.2 Renewal of plates
 - 6.3 Doubler on plates
 - 6.4 Renewal of internals/stiffeners
 - 6.5 Renewal of internals/stiffeners - transitions inverted angles/bulb profiles
 - 6.6 Application of Doubling Straps
 - 6.7 Welding of pitting corrosion
 - 6.8 Welding repairs of cracks
 - 6.9 Grinding of shallow cracks

REFERENCES

1. IACS "Bulk Carriers - Guidelines for Surveys, Assessment and Repair of Hull Structure"
2. TSCF "Guidelines for the inspection and maintenance of double hull tanker structures"
3. TSCF "Guidance manual for the inspection and condition assessment of tanker structures"
4. IACS UR W 11 "Normal and higher strength hull structural steels"
5. IACS UR W 13 "Thickness tolerances of steel plates and wide flats"
6. IACS UR W 17 "Approval of consumables for welding normal and higher strength hull structural steels"
7. IACS Z 10.1 "Hull surveys of oil tankers" and Z 10.2 "Hull surveys of bulk carriers" Table IV
8. IACS UR Z 13 "Voyage repairs and maintenance"
9. IACS Recommendation 12 "Guidelines for surface finish of hot rolled steel plates and wide flats"
10. IACS Recommendation 20 "Non-destructive testing of ship hull steel welds"

**No.
47**
(cont)**1. Scope**

1.1 This standard provides guidance on quality of repair of hull structures. The standard covers permanent repairs of existing ships.

Whereas the standard generally applies to

- conventional ship types,
- parts of hull covered by the rules of the Classification Society,
- hull structures constructed from normal and higher strength hull structural steel, the applicability of the standard is in each case to be agreed upon by the Classification Society.

The standard does generally not apply to repair of

- special types of ships as e.g. gas tankers
- structures fabricated from stainless steel or other, special types or grades of steel

1.2 The standard covers typical repair methods and gives guidance on quality standard on the most important aspects of such repairs. Unless explicitly stated elsewhere in the standard, the level of workmanship reflected herein will in principle be acceptable for primary and secondary structure of conventional design. A more stringent standard may however be required for critical and highly stressed areas of the hull, and is to be agreed with the Classification Society in each case. In assessing the criticality of hull structure and structural components, reference is made to ref. 1, 2 and 3.

1.3 Restoration of structure to the original standard may not constitute durable repairs of damages originating from insufficient strength or inadequate detail design. In such cases strengthening or improvements beyond the original design may be required. Such improvements are not covered by this standard, however it is referred to ref. 1, 2 and 3.

**No.
47**
(cont)**2. General requirements for repairs and repairers**

2.1 In general, when hull structure covered by classification is to be subjected to repairs, the work is to be carried out under the supervision of the Surveyor to the Classification Society. Such repairs are to be agreed prior to commencement of the work.

2.2 Repairs are to be carried out by workshops, repair yards or personnel who have demonstrated their capability to carry out hull repairs of adequate quality in accordance with the Classification Society's requirements and this standard.

2.3 Repairs are to be carried out under working conditions that facilitate sound repairs. Provisions are to be made for proper accessibility, staging, lighting and ventilation. Welding operations are to be carried out under shelter from rain, snow and wind.

2.4 Welding of hull structures is to be carried out by qualified welders, according to approved and qualified welding procedures and with welding consumables approved by the Classification Society, see Section 3. Welding operations are to be carried out under proper supervision of the repair yard.

2.5 Where repairs to hull which affect or may affect classification are intended to be carried out during a voyage, complete repair procedure including the extent and sequence of repair is to be submitted to and agreed upon by the Surveyor to the Classification Society reasonably in advance of the repairs. See Ref. 8.

**No.
47**

(cont)

3. Qualification of personnel**3.1 Qualification of welders**

3.1.1 Welders are to be qualified in accordance with the procedures of the Classification Society or to a recognised national or international standard, e.g. EN 287, ISO 9606, ASME Section IX, ANSI/AWS D1.1. Recognition of other standards is subject to submission to the Classification Society for evaluation. Repair yards and workshops are to keep records of welders qualification and, when required, furnish valid approval test certificates.

3.1.2 Welding operators using fully mechanised or fully automatic processes need generally not pass approval testing, provided that production welds made by the operators are of the required quality. However, operators are to receive adequate training in setting or programming and operating the equipment. Records of training and production test results shall be maintained on individual operator's files and records, and be made available to the Classification Society for inspection when requested.

3.2 Qualification of welding procedures

Welding procedures are to be qualified in accordance with the procedures of the Classification Society or a recognised national or international standard, e.g. EN288, ISO 9956, ASME Section IX, ANSI/AWS D1.1. Recognition of other standards is subject to submission to the Classification Society for evaluation. The welding procedure should be supported by a welding procedure qualification record. The specification is to include the welding process, types of electrodes, weld shape, edge preparation, welding techniques and positions.

3.3 Qualification of NDE operators

3.3.1 Personnel performing non destructive examination for the purpose of assessing quality of welds in connection with repairs covered by this standard, are to be qualified in accordance with the Classification Society rules or to a recognised international or national qualification scheme. Records of operators and their current certificates are to be kept and made available to the Surveyor for inspection.

**No.
47**

(cont)

4. Materials**4.1 General requirements for materials**

4.1.1 The requirements for materials used in repairs are in general the same as the requirements for materials specified in the Classification Society's rules for new constructions, (ref. 5).

4.1.2 Replacement material is in general to be of the same grade as the original approved material. Alternatively, material grades complying with recognised national or international standards may be accepted by the Classification Societies provided such standards give equivalence to the requirements of the original grade or are agreed by the Classification Society. For assessment of equivalency between steel grades, the general requirements and guidelines in Section 4.2 apply.

4.1.3 Higher tensile steel is not to be replaced by steel of a lesser strength unless specially approved by the Classification Society.

4.1.4 Normal and higher strength hull structural steels are to be manufactured at works approved by the Classification Society for the type and grade being supplied.

4.1.5 Materials used in repairs are to be certified by the Classification Society applying the procedures and requirements in the rules for new constructions. In special cases, and normally limited to small quantities, materials may be accepted on the basis of alternative procedures for verification of the material's properties. Such procedures are subject to agreement by the Classification Society in each separate case.

4.2 Equivalency of material grades

4.2.1 Assessment of equivalency between material grades should at least include the following aspects;

- heat treatment/delivery condition
- chemical composition
- mechanical properties
- tolerances

4.2.2 When assessing the equivalence between grades of normal or higher strength hull structural steels up to and including grade E40 in thickness limited to 50 mm, the general requirements in Table 4.1 apply.

4.2.3 Guidance on selection of steel grades to certain recognised standards equivalent to hull structural steel grades specified in Classification Societies' rules is given in Table 4.2

**No.
47**
(cont)

Items to be considered	Requirements	Comments
Chemical composition	<ul style="list-style-type: none"> - C; equal or lower - P and S; equal or lower - Mn; approximately the same but not exceeding 1.6% - Fine grain elements; in same amount - Detoxidation practice 	The sum of the elements, e.g. Cu, Ni, Cr and Mo should not exceed 0.8%
Mechanical properties	<ul style="list-style-type: none"> - Tensile strength; equal or higher - Yield strength; equal or higher - Elongation; equal or higher - Impact energy; equal or higher at same or lower temperature, where applicable 	Actual yield strength should not exceed Classification Society Rule minimum requirements by more than 80 N/mm ²
Condition of supply	Same or better	Heat treatment in increasing order; <ul style="list-style-type: none"> - as rolled (AR) - controlled rolled (CR) - normalised (N) - thermo-mechanically rolled (TM)¹⁾ - quenched and tempered (QT)¹⁾ ¹⁾ TM- and QT-steels are not suitable for hot forming
Tolerances	- Same or stricter	Permissible under thickness tolerances; <ul style="list-style-type: none"> - plates: 0.3 mm - sections: according to recognised standards

Table 4.1 Minimum extent and requirements to assessment of equivalency between normal or higher strength hull structural steel grades

**No.
47**
(cont)

Steel grades according to Classification Societies' rules (ref. 5)						Comparable steel grades				
Grade	Yield stress R _{eH} min. N/mm ²	Tensile strength R _m N/mm ²	Elongation A ₅ min. %	Average impact energy Temp.		ISO 630-80 4950/2/3/ 1981	EN EN 10025-93 EN 10113-93	ASTM A 131	JIS G 3106	
				°C	J, min. L T					
A	235	400-502	22	+20	-	-	Fe 360B	S235JRG2	A	SM41B
B				0	27	20	Fe 360C	S235J0	B	SM41B
D				-20	27	20	Fe 360D	S235J2G3	D	(SM41C)
E				-40	27	20	-	S275NL/ML	E	-
A 27				265	400-530	22	0	27	20	Fe 430C
D 27	-20	Fe 430D	S275N/M				-			-
E 27	-40	-	S275NL/ML				-			-
A 32	315	440-590	22	0	31	22	-	-	AH32	SM50B
D 32				-20			-	-	DH32	(SM50C)
E 32				-40			-	-	EH32	-
A 36	355	490-620	21	0	34	24	Fe 510C	S355N/M	AH36	SM53B
D 36				-20			Fe 510D	S355N/M	DH36	(SM53C)
E 36				-40			E355E	S355NL/ML	EH36	-
A 40	390	510-650	20	0	41	27	E390CC	S420N/M	AH40	(SM58)
D 40				-20			E390DD	S420N/M	DH40	-
E 40				-40			E390E	S420NL/ML	EH40	-

Note: In selecting comparable steels from this table, attention should be given to the requirements of Table 4.1 and the dimension requirements of the product with respect to Classification Society rules.

Table 4.2 Guidance on steel grades comparable to the normal and high strength hull structural steel grades given in Classification Society rules

No. 47

(cont)

5. General requirements to welding

5.1 Correlation of welding consumables with hull structural steels

5.1.1 For the different hull structural steel grades welding consumables are to be selected in accordance with IACS UR W17 (see Ref.6).

5.2 General requirements to preheating and drying out

5.2.1 The need for preheating is to be determined based on the chemical composition of the materials, welding process and procedure and degree of joint restraint.

5.2.2 A minimum preheat of 50° C is to be applied when ambient temperature is below 0° C. Dryness of the welding zone is in all cases to be ensured.

5.2.3 Guidance on recommended minimum preheating temperature for higher strength steel is given in Table 5.1. For automatic welding processes utilising higher heat input e.g. submerged arc welding, the temperatures may be reduced by 50° C. For re-welding or repair of welds, the stipulated values are to be increased by 25° C.

Carbon equivalent ¹⁾	Recommended minimum preheat temperature (° C)		
	$t_{comb} \leq 50 \text{ mm}^2)$	$50 \text{ mm} < t_{comb} \leq 70 \text{ mm}^2)$	$t_{comb} > 70 \text{ mm}^2)$
Ceq ≤ 0.39	-	50	
Ceq ≤ 0.41	-	75	
Ceq ≤ 0.43	-	50	100
Ceq ≤ 0.45	50	100	125
Ceq ≤ 0.47	100	125	150
Ceq ≤ 0.50	125	150	175

Table 5.1 Preheating temperature

5.3 Dry welding on hull plating below the waterline of vessels afloat

5.3.1 Welding on hull plating below the waterline of vessels afloat is acceptable only on normal and higher strength steels with specified yield strength not exceeding 355 MPa and only for local repairs. Welding involving other high strength steels or more extensive repairs against water backing is subject to special consideration and approval by the Classification Society of the welding procedure.

5.3.2 Low-hydrogen electrodes or welding processes are to be used when welding on hull plating against water backing. Coated low-hydrogen electrodes used for manual metal arc welding should be properly conditioned to ensure a minimum of moisture content.

5.3.3 In order to ensure dryness and to reduce the cooling rate, the structure is to be preheated by a torch or similar prior to welding, to a temperature of minimum 5° C or as specified in the welding procedure.

**No.
47**
(cont)

Notes:

$$1) \quad C_{eq} = C + \frac{Mn}{6} + \frac{Cr + Mo + V}{5} + \frac{Ni + Cu}{15} (\%)$$

2) Combined thickness $t_{comb} = t_1 + t_2 + t_3 + t_4$, see figure

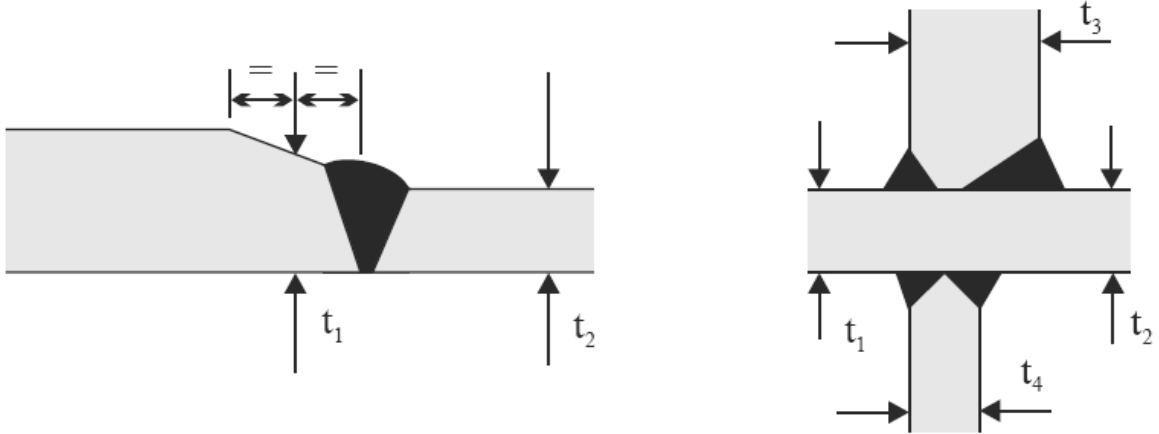

No. 47

(cont)

6. Repair quality standard

6.1 Welding, general

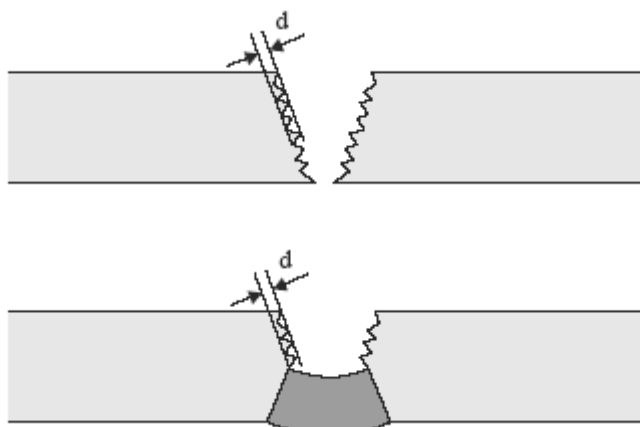

Fig 6.1 Groove roughness

Item	Standard	Limit	Remarks
Material Grade	Same as original or higher		See Section 4
Welding Consumables	IACS UR W17 (ref. 6)	Approval according to equivalent international standard	
Groove / Roughness	See note and Fig 6.1	$d < 1.5 \text{ mm}$	Grind smooth
Pre-Heating	See Table 5.1	Steel temperature not lower than 5°C	
Welding with water on the outside	See Section 5.3	Acceptable for normal and high strength steels	- Moisture to be removed by a heating torch
Alignment	As for new construction		
Weld Finish	IACS Recommendation 20 (ref. 10)		
NDE	IACS Recommendation 20 (ref. 10)	At random with extent to be agreed with attending surveyors	

Note:

Slag, grease, loose mill scale, rust and paint, other than primer, to be removed.

**No.
47**
(cont)

6.2 Renewal of plates

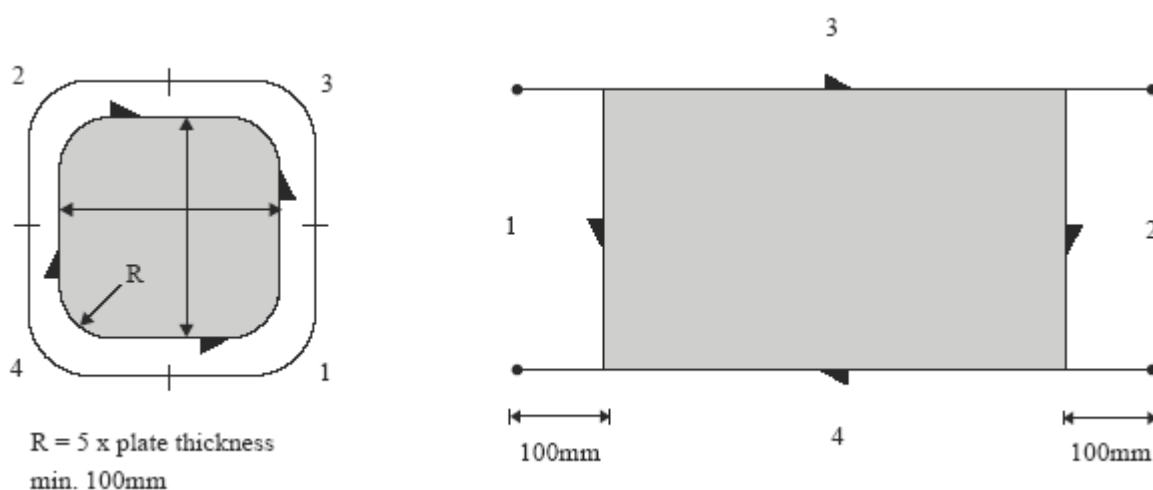

Fig 6.2 Welding sequence for inserts

Item	Standard	Limit	Remarks
Size Insert	Min. 300 x 300 mm R = 5 x thickness Circular inserts: D _{min} = 200 mm	Min. 200 x 200 mm Min R = 100 mm	
Material Grade	Same as original or higher		See Section 4.
Edge Preparation	As for new construction		In case of non compliance increase the amount of NDE
Welding Sequence	See Fig 6.2 Weld sequence is 1 → 2 → 3 → 4		For primary members sequence 1 and 2 transverse to the main stress direction
Alignment	As for new construction		
Weld Finish	IACS Recommendation 20 (ref. 10)		
NDE	IACS Recommendation 20 (ref. 10)		

**No.
47**
(cont)

6.3 Doublers on plating

Local doublers are normally only allowed as temporary repairs, except as original compensation for openings, within the main hull structure.

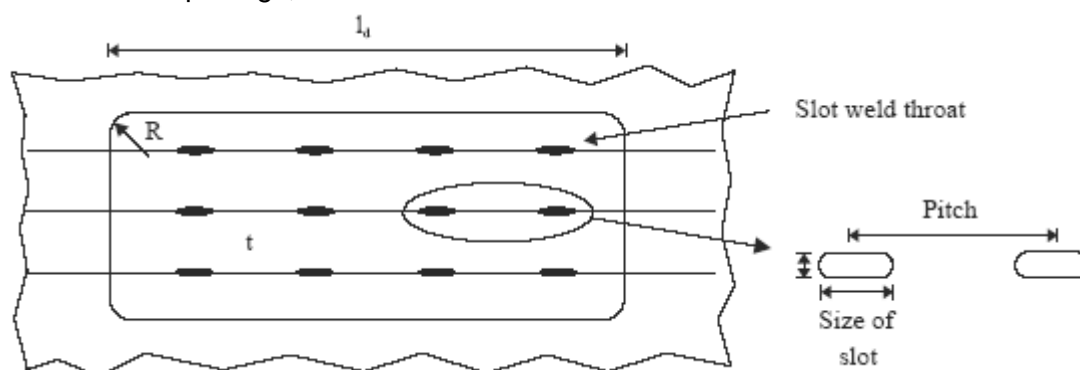

Fig 6.3 Doublers on plates

Item	Standard	Limit	Remarks
Existing Plating		General: $t \geq 5$ mm	For areas where existing plating is less than 5 mm plating a permanent repair by insert is to be carried out.
Extent / Size	Rounded off corners.	min 300 x 300 mm $R \geq 50$ mm	
Thickness of Doubler (td)	$td \leq tp$ (tp = original thickness of existing plating)	$td > tp/3$	
Material Grade	Same as original plate		See Section 4
Edge Preparation	As for [newbuilding] new construction		Doublers welded on primary strength members: (Le : leg length) when $t > Le + 5$ mm, the edge to be tapered (1:4)
Welding	As for [newbuilding] new construction		Welding sequence similar to insert plates.
Weld Size (throat thickness)	Circumferential and in slots: $0.6 \times td$		
Slot Welding	Normal size of slot: (80-100) x $2 td$ Distance from doubler edge and between slots: $d \leq 15 td$	Max pitch between slots 200 mm $d_{max} = 500$ mm	For doubler extended over several supporting elements, see Figure 6.3
NDE	IACS Recommendation 20 (ref. 10)		

**No.
47**
(cont)

6.4 Renewal of internals/stiffeners

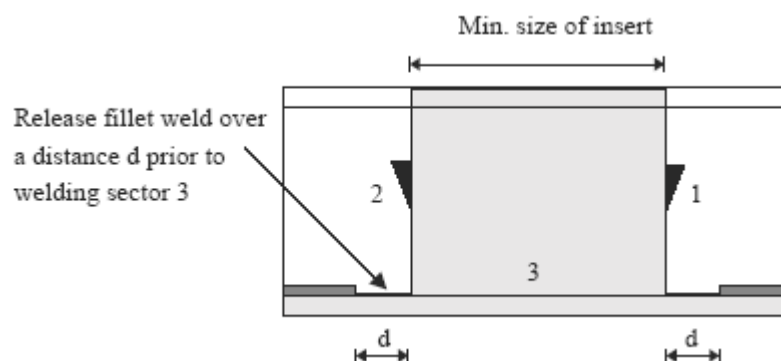

Fig 6.4 Welding sequence for inserts of stiffeners

Item	Standard	Limit	Remarks
Size Insert	Min. 300 mm	Min. 200 mm	
Material Grade	Same as original or higher		See Section 4.
Edge Preparation	As for new construction. Fillet weld stiffener web / plate to be released over min. $d = 150$ mm		
Welding Sequence	See Fig 6.4 Welding sequence is 1 → 2 → 3		
Alignment	As for new construction		
Weld Finish	IACS Recommendation 20 (ref. 10)		
NDE	IACS Recommendation 20 (ref. 10)		

**No.
47**
(cont)

6.5 Renewal of internals/stiffeners – transitions inverted angle/bulb profile

The application of the transition is allowed for secondary structural elements.

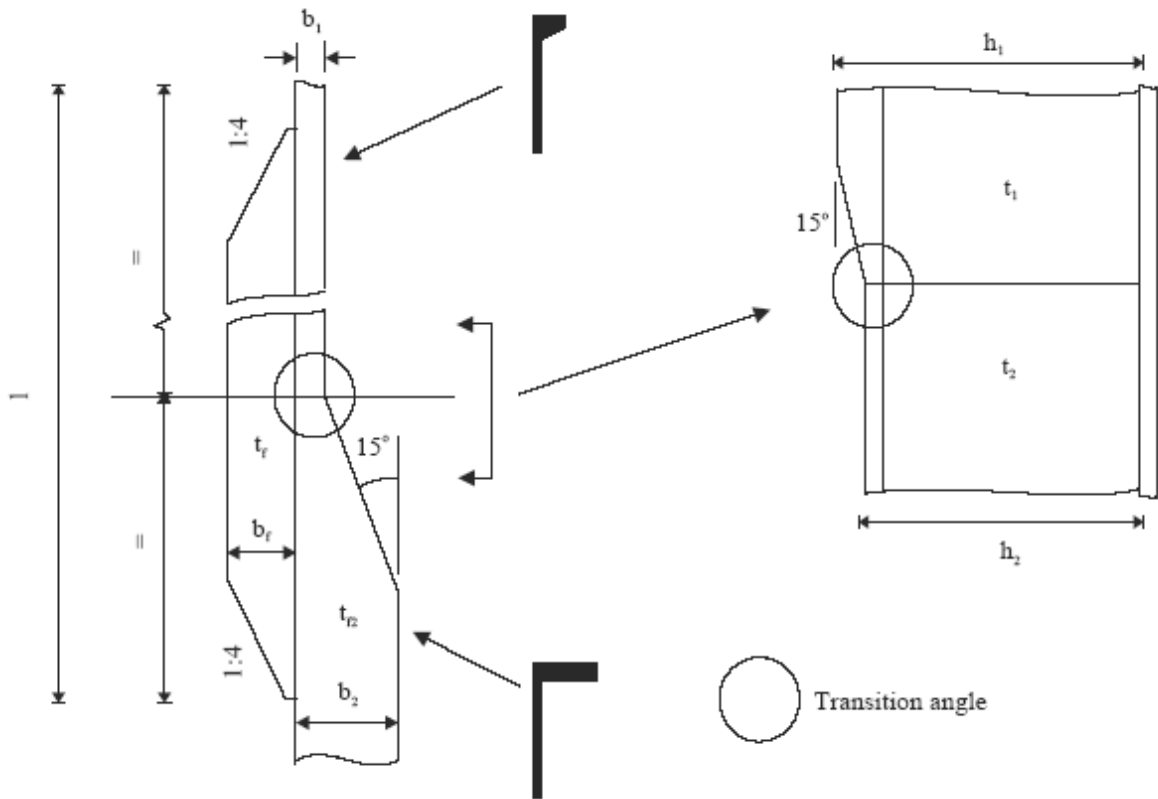

Fig 6.5 Transition between inverted angle and bulb profile

Item	Standard	Limit	Remarks
$(h_1 - h_2)$	$\leq 0.25 \times b_1$		
$ t_1 - t_2 $	2 mm		Without tapering transition.
Transition Angle	15 degrees		At any arbitrary section
Flanges	$t_f = t_{f2}$ $b_f = b_{f2}$		
Length of Flatbar	$4 \times h_1$		
Material			See Section 4.

No. 47

(cont)

6.6 Application of Doubling Straps

In certain instances, doubling straps are used as a means to strengthen and reinforce primary structure. Where this has been agreed and approved, particular attention should be paid to:

- the end termination points of the straps, so that toe support is such that no isolated hard point occurs.
- in the case of application of symmetrical or asymmetrical-ended straps, the corners at the end of the tapering should be properly rounded.
- any butts between lengths of doubling straps, so that there is adequate separation of the butt weld from the primary structure below during welding, and so that a high quality root run under controlled circumstances is completed prior to completing the remainder of the weld. Ultrasonic testing should be carried out on completion to verify full penetration.

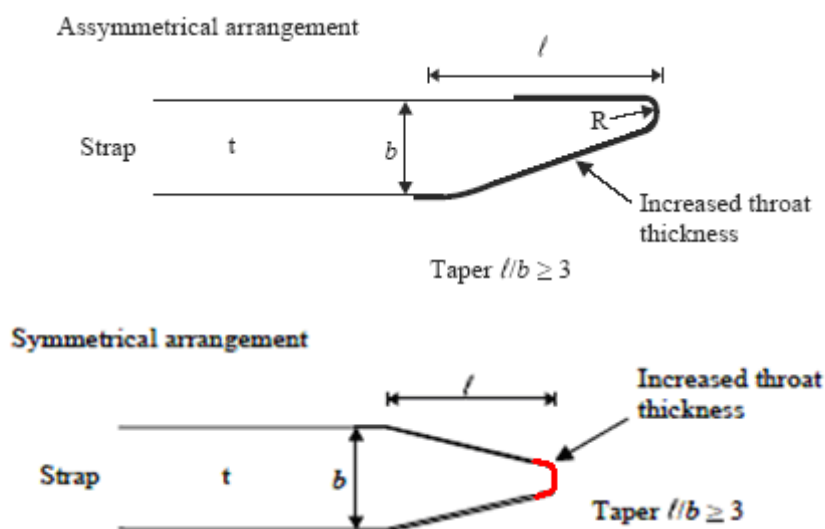

Fig 6.6 Application of Doubling Straps

Item	Standard	Limit	Remarks
Tapering	$l/b > 3$		Special consideration to be drawn to design of strap terminations in fatigue sensitive areas.
Radius	$0.1 \times b$	min 30 mm	
Material			See paragraph 2.0 General requirement to materials.
Weld Size			Depending on number and function of straps. Throat thickness to be increased 15 % toward ends.
Welding	Welding sequence from middle towards the free ends		See sketch. For welding of lengths > 1000 mm step welding to be applied.

No. 47

(cont)

6.7 Welding of pitting corrosion

Notes:

Shallow pits may be filled by applying coating or pit filler. Pits can be defined as shallow when their depth is less than $1/3$ of the original plate thickness.

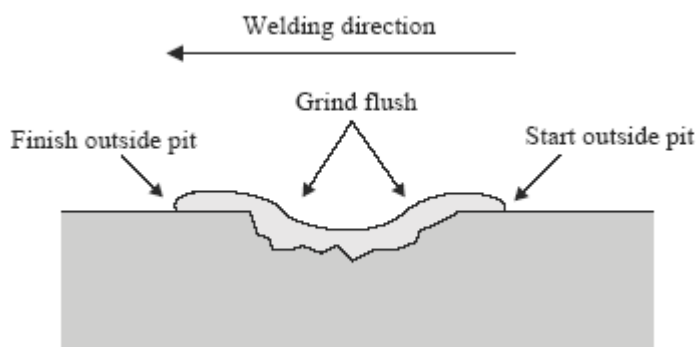

Fig 6.7 Welding of pits

Item	Standard	Limit	Remarks
Extent / Depth	Pits / grooves are to be welded flush with the original surface.	If deep pits or grooves are clustered together or remaining thickness is less than 6 mm, the plates should be renewed.	See also IACS Recommendation 12 (ref. 9)
Cleaning	Heavy rust to be removed		
Pre-Heating	See Table 5.1	Required when ambient temperature $< 5^{\circ}\text{C}$	Always use propane torch or similar to remove any moisture
Welding Sequence	Reverse direction for each layer		See also IACS Recommendation 12 (ref. 9)
Weld Finish	IACS Recommendation 20 (ref. 10)		
NDE	IACS Recommendation 20 (ref. 10)	Min. 10% extent	Preferably MPI

Reference is made to TSCF Guidelines, Ref. 2 & 3.

**No.
47**
(cont)

6.8 Welding repairs for cracks

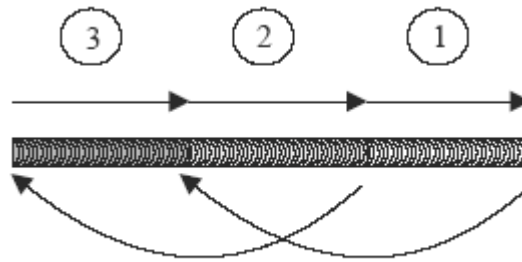

Fig 6.8.a Step back technique

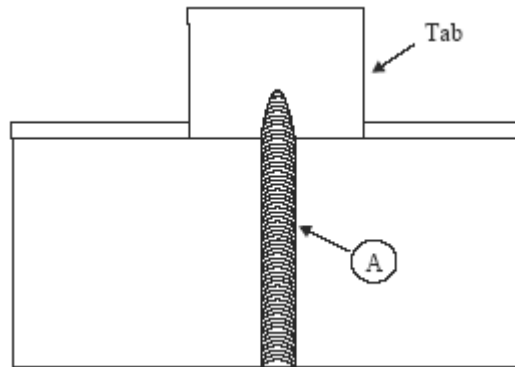

Fig 6.8.b End crack termination

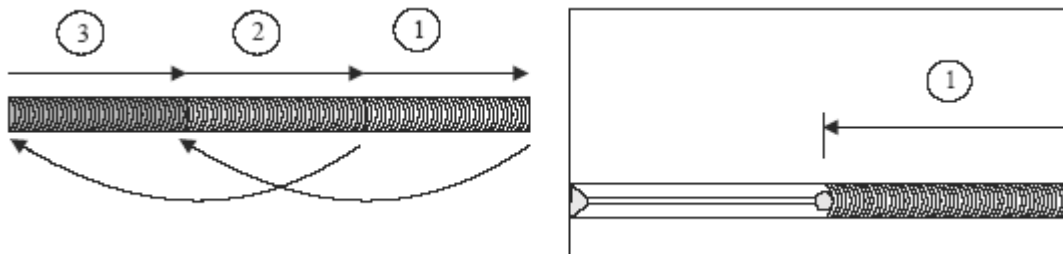

Fig 6.8.c Welding sequence for cracks with length less than 300 mm

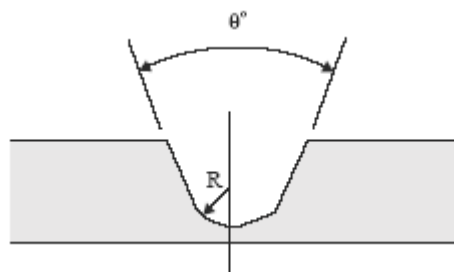

Fig 6.8.d Groove preparation (U-groove left and V-groove right)

No. 47

(cont)

Item	Standard	Limit	Remarks
Groove Preparation	$\theta = 45-60^\circ$ $r = 5 \text{ mm}$		For through plate cracks as for newbuilding. Also see Fig 6.8.d
Termination	Termination to have slope 1:3		For cracks ending on edges weld to be terminated on a tab see Fig 6.8.b
Extent	On plate max. 400 mm length. Vee out 50 mm past end of crack	On plate max 500 mm. Linear crack, not branched	
Welding Sequence	See Fig 6.8.c for sequence and direction	For cracks longer than 300 mm step-back technique should be used Fig 6.8.a	Always use low hydrogen welding consumables
Weld Finish	IACS Recommendation 20 (ref. 10)		
NDE	IACS Recommendation 20 (ref. 10)	100 % MP or PE of groove	100 % surface crack detection + UE or RE for butt joints

No. 47
(cont)

6.9 Grinding of shallow cracks

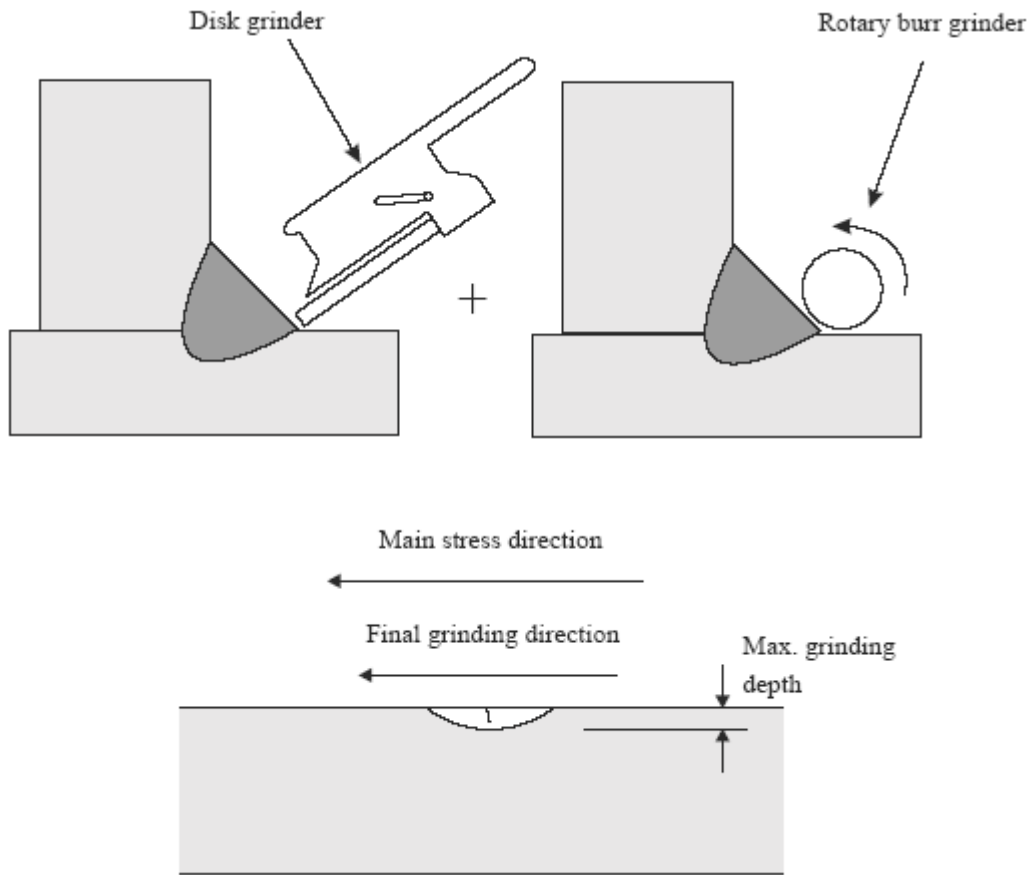

Fig 6.9 Grinding

Item	Standard	Limit	Remarks
Extent	For short cracks only max. 4 t t = plate thickness	Max. length 100 mm	See also IACS Recommendation 12, (ref. 9)
Grinding Direction	Final grinding microgrooves parallel to main stress direction		Grinding always to be finished by a rotating burr and not a disk grinder
Grinding Depth	Max. 0.2 t t = Plate thickness		Always smooth transition
NDE	IACS Recommendation 20 (ref. 10)		100 % MPI

End of Part B,
End of Document