

## S8 Bow Doors and Inner Doors

(1982)  
(Rev. 2  
1995)  
(Corr.  
1997)  
(Rev.3  
Nov  
2003)  
(Rev.4  
Dec  
2010)

### S8.1 General

#### S8.1.1 Application

S8.1.1a These requirements are for the arrangement, strength and securing of bow doors and inner doors leading to a complete or long forward enclosed superstructures, or to a long non-enclosed superstructure, where fitted to attain minimum bow height equivalence.

The requirements apply to all ro-ro passenger ships and ro-ro cargo ships engaged on international voyages and also to ro-ro passenger ships and ro-ro cargo ships engaged only in domestic (non-international) voyages, except where specifically indicated otherwise herein.

The requirements are not applicable to high speed, light displacement craft as defined in the IMO Code of Safety for High Speed Craft.

S8.1.1b Two types of bow door are provided for:

- **Visor doors** opened by rotating upwards and outwards about a horizontal axis through two or more hinges located near the top of the door and connected to the primary structure of the door by longitudinally arranged lifting arms,
- **Side-opening doors** opened either by rotating outwards about a vertical axis through two or more hinges located near the outboard edges or by horizontal translation by means of linking arms arranged with pivoted attachments to the door and the ship. It is anticipated that side-opening bow doors are arranged in pairs.

Other types of bow door will be specially considered in association with the applicable requirements of these rules.

#### S8.1.2 Arrangement

S8.1.2a Bow doors are to be situated above the freeboard deck. A watertight recess in the freeboard deck located forward of the collision bulkhead and above the deepest waterline fitted for arrangement of ramps or other related mechanical devices may be regarded as a part of the freeboard deck for the purpose of this requirement.

---

Footnote:

It was agreed by IACS Council in August 1995 that this UR S8 should be uniformly applied by IACS Members to new ships as soon as possible but not later than 1 July 1996 and, with immediate effect, when approving plans for bow arrangements on new ships, Members should strongly recommend that the requirements as set out in the revised UR S8 are complied in full.

---

Note:

Changes introduced in Rev.4 are to be uniformly implemented by IACS Members from 1 January 2012.

## S8 (cont)

S8.1.2b An inner door is to be fitted. The inner door is to be part of the collision bulkhead. The inner door needs not be fitted directly above the bulkhead below, provided it is located within the limits specified for the position of the collision bulkhead, refer to regulation II-1/12 of the SOLAS Convention. A vehicle ramp may be arranged for this purpose, provided its position complies with regulation II-1/12 of the SOLAS Convention. If this is not possible a separate inner weathertight door is to be installed, as far as practicable within the limits specified for the position of the collision bulkhead.

S8.1.2c Bow doors are to be so fitted as to ensure tightness consistent with operational conditions and to give effective protection to inner doors. Inner doors forming part of the collision bulkhead are to be weathertight over the full height of the cargo space and arranged with fixed sealing supports on the aft side of the doors.

S8.1.2d Bow doors and inner doors are to be arranged so as to preclude the possibility of the bow door causing structural damage to the inner door or to the collision bulkhead in the case of damage to or detachment of the bow door. If this is not possible, a separate inner weathertight door is to be installed, as indicated in S8.1.2b.

S8.1.2e The requirements for inner doors are based on the assumption that vehicle are effectively lashed and secured against movement in stowed position.

### S8.1.3 Definitions

- Securing device* - a device used to keep the door closed by preventing it from rotating about its hinges.
- Supporting device* - a device used to transmit external or internal loads from the door to a securing device and from the securing device to the ship's structure, or a device other than a securing device, such as a hinge, stopper or other fixed device, that transmits loads from the door to the ship's structure.
- Locking device* - a device that locks a securing device in the closed position.
- Ro-ro passenger ship* - a passenger ship with ro-ro spaces or special category spaces.
- Ro-ro spaces* - are spaces not normally sub-divided in any way and normally extending to either a substantial length or the entire length of the ship, in which motor vehicles with fuel in their tanks for their own propulsion and/or goods (packaged or in bulk, in or on rail or road cars, vehicles (including road or rail tankers), trailers, containers, pallets, demountable tanks or in or on similar stowage units or, other receptacles) can be loaded and unloaded normally in a horizontal direction.
- Special category spaces* - are those enclosed vehicle spaces above or below the bulkhead deck, into and from which vehicles can be driven and to which passengers have access. Special category spaces may be accommodated on more than one deck provided that the total overall clear height for vehicles does not exceed 10m.

# S8

(cont)

## S8.2 Strength Criteria

### S8.2.1 Primary structure and Securing and Supporting devices

S8.2.1a Scantlings of the primary members, securing and supporting devices of bow doors and inner doors are to be determined to withstand the design loads defined in S8.3, using the following permissible stresses:

shear stress: 
$$\tau = \frac{80}{k} N / mm^2$$

bending stress: 
$$\sigma = \frac{120}{k} N / mm^2$$

equivalent stress: 
$$\sigma_c = \sqrt{\sigma^2 + 3\tau^2} = \frac{150}{k} N / mm^2$$

where  $k$  is the material factor as given in S4, but is not to be taken less than 0.72 unless a direct fatigue analysis is carried out.

S8.2.1b The buckling strength of primary members is to be verified as being adequate.

S.8.2.1c For steel to steel bearings in securing and supporting devices, the nominal bearing pressure calculated by dividing the design force by the projected bearing area is not to exceed  $0.8\sigma_F$ , where  $\sigma_F$  is the yield stress of the bearing material. For other bearing materials, the permissible bearing pressure is to be determined according to the manufacturer's specification.

S8.2.1d The arrangement of securing and supporting devices is to be such that threaded bolts do not carry support forces. The maximum tension in way of threads of bolts not carrying support forces is not to exceed:

$$\frac{125}{k} N / mm^2$$

# S8

(cont)

## S8.3 Design loads

### S8.3.1 Bow doors

S8.3.1a The design external pressure, in kN/m<sup>2</sup>, to be considered for the scantlings of primary members, securing and supporting devices of bow doors is not to be less than the pressure normally used by the Society nor than:

$$P_e = 2.75\lambda C_H (0.22 + 0.15 \tan \alpha)(0.4V \sin \beta + 0.6L^{0.5})^2$$

where:

V contractual ship's speed, in knots,

L ship's length, in m, but need not be taken greater than 200 metres,

$\lambda$  coefficient depending on the area where the ship is intended to be operated:

$\lambda = 1$  for seagoing ships,

$\lambda = 0.8$  for ships operated in coastal waters,

$\lambda = 0.5$  for ships operated in sheltered waters,

Note: Coastal waters and sheltered waters are defined according to the practice of each Classification Society. As an example, coastal waters may be defined as areas where significant wave heights do not exceed 4m for more than three hours a year and sheltered waters as areas where significant wave heights do not exceed 2m for more than three hours a year.

$C_H = 0.0125 L$  for  $L < 80m$   
 $1$  for  $L \geq 80m$

$\alpha$  flare angle at the point to be considered, defined as the angle between a vertical line and the tangent to the side shell plating, measured in a vertical plane normal to the horizontal tangent to the shell plating,

$\beta$  entry angle at the point to be considered, defined as the angle between a longitudinal line parallel to the centreline and the tangent to the shell plating in a horizontal plane.

S8.3.1b The design external forces, in kN, considered for the scantlings of securing and supporting devices of bow doors are not to be less than:

$$\begin{aligned} F_x &= P_e A_x \\ F_y &= P_e A_y \\ F_z &= P_e A_z \end{aligned}$$

where:

$A_x$  area, in m<sup>2</sup>, of the transverse vertical projection of the door between the levels of the bottom of the door and the top of the upper deck bulwark, or between the bottom of the door and the top of the door, including the bulwark, where it is part

## S8 (cont)

of the door, whichever is lesser. Where the flare angle of the bulwark is at least 15 degrees less than the flare angle of the adjacent shell plating, the height from the bottom of the door may be measured to the upper deck or to the top of the door, whichever is lesser. In determining the height from the bottom of the door to the upper deck or to the top of the door, the bulwark is to be excluded.

- $A_y$  area, in  $m^2$ , of the longitudinal vertical projection of the door between the levels of the bottom of the door and the top of the upper deck bulwark, or between the bottom of the door and the top of the door, including the bulwark, where it is part of the door, whichever is lesser. Where the flare angle of the bulwark is at least 15 degrees less than the flare angle of the adjacent shell plating, the height from the bottom of the door may be measured to the upper deck or to the top of the door, whichever is lesser.
- $A_z$  area, in  $m^2$ , of the horizontal projection of the door between the bottom of the door and the top of the upper deck bulwark, or between the bottom of the door and the top of the door, including the bulwark, where it is part of the door, whichever is the lesser. Where the flare angle of the bulwark is at least 15 degrees less than the flare angle of the adjacent shell plating, the height from the bottom of the door may be measured to the upper deck or to the top of the door, whichever is lesser.
- $h$  height, in m, of the door between the levels of the bottom of the door and the upper deck or between the bottom of the door and the top of the door, whichever is the lesser,
- $l$  length, in m, of the door at a height  $h/2$  above the bottom of the door,
- $W$  breadth, in m, of the door at a height  $h/2$  above the bottom of the door,
- $P_e$  external pressure, in  $kN/m^2$ , as given in S8.3.1a with angles  $\alpha$  and  $\beta$  defined as follows:
- $\alpha$  flare angle measured at the point on the bow door,  $l/2$  aft of the stem line on the plane  $h/2$  above the bottom of the door, as shown in Figure 1,
- $\beta$  entry angle measured at the same point as  $\alpha$ .

For bow doors, including bulwark, of unusual form or proportions, e.g. ships with a rounded nose and large stem angles, the areas and angles used for determination of the design values of external forces may require to be specially considered.

S8.3.1c For visor doors the closing moment  $M_y$  under external loads, in  $kN.m$ , is to be taken as:

$$M_y = F_x a + 10Wc - F_z b$$

where:

- $W$  mass of the visor door, in t,
- $a$  vertical distance, in m, from visor pivot to the centroid of the transverse vertical projected area of the visor door, as shown in Figure 2,

**S8**  
(cont)

- b horizontal distance, in m, from visor pivot to the centroid of the horizontal projected area of the visor door, as shown in Figure 2,
- c horizontal distance, in m, from visor pivot to the centre of gravity of visor mass, as shown in Figure 2.

S8.3.1d Moreover, the lifting arms of a visor door and its supports are to be dimensioned for the static and dynamic forces applied during the lifting and lowering operations, and a minimum wind pressure of  $1.5\text{kN/m}^2$  is to be taken into account.

### S8.3.2 Inner doors

S8.3.2a The design external pressure  $p_e$ , in  $\text{kN/m}^2$ , considered for the scantlings of primary members, securing and supporting devices and surrounding structure of inner doors is to be taken as the greater of the following:

- $p_e = 0.45 L$ ,
- hydrostatic pressure  $p_h = 10h$ , where  $h$  is the distance, in m, from the load point to the top of the cargo space,

where  $L$  is the ship's length, as defined in S8.3.1a.

S8.3.2b The design internal pressure  $p_i$ , in  $\text{kN/m}^2$ , considered for the scantlings of securing devices of inner doors is not to be less than:

$$p_i = 25$$

**S8**  
(cont)**S8.4 Scantlings of bow doors**

S8.4.1a The strength of bow doors is to be commensurate with that of the surrounding structure.

S8.4.1b Bow doors are to be adequately stiffened and means are to be provided to prevent lateral or vertical movement of the doors when closed. For visor doors adequate strength for the opening and closing operations is to be provided in the connections of the lifting arms to the door structure and to the ship structure.

**S8.4.2 Plating and secondary stiffeners**

S8.4.2a The thickness of the bow door plating is not to be less than that required for the side shell plating, using bow door stiffener spacing, but in no case less than the minimum required thickness of fore end shell plating.

S8.4.2b The section modulus of horizontal or vertical stiffeners is not to be less than that required for end framing. Consideration is to be given, where necessary, to differences in fixity between ship's frames and bow doors stiffeners.

S8.4.2c The stiffener webs are to have a net sectional area, in cm<sup>2</sup>, not less than:

$$A = \frac{Qk}{10}$$

where:

Q shear force, in kN, in the stiffener calculated by using uniformly distributed external pressure  $p_e$  as given in S8.3.1a.

**S8.4.3 Primary structure**

S8.4.3a The bow door secondary stiffeners are to be supported by primary members constituting the main stiffening of the door.

S8.4.3b The primary members of the bow door and the hull structure in way are to have sufficient stiffness to ensure integrity of the boundary support of the door.

S8.4.3c Scantlings of the primary members are generally to be supported by direct strength calculations in association with the external pressure given in S8.3.1a and permissible stresses given in S8.2.1a. Normally, formulae for simple beam theory may be applied to determine the bending stress. Members are to be considered to have simply supported end connections.

**S8**  
(cont)**S8.5 Scantlings of inner doors**

## S8.5.1 General

S8.5.1a Scantlings of the primary members are generally to be supported by direct strength calculations in association with the external pressure given in S8.3.2a and permissible stresses given in S8.2.1a. Normally, formulae for simple beam theory may be applied.

S8.5.1b Where inner doors also serve as a vehicle ramps, the scantlings are not to be less than those required for vehicle decks.

S8.5.1c The distribution of the forces acting on the securing and supporting devices is generally to be supported by direct calculations taking into account the flexibility of the structure and the actual position and stiffness of the supports.

## S8 (cont)

### S8.6 Securing and supporting of bow doors

#### S8.6.1 General

S8.6.1a Bow doors are to be fitted with adequate means of securing and supporting so as to be commensurate with the strength and stiffness of the surrounding structure. The hull supporting structure in way of the bow doors is to be suitable for the same design loads and design stresses as the securing and supporting devices. Where packing is required, the packing material is to be of a comparatively soft type, and the supporting forces are to be carried by the steel structure only. Other types of packing may be considered. Maximum design clearance between securing and supporting devices is not generally to exceed 3 mm.

A means is to be provided for mechanically fixing the door in the open position.

S8.6.1b Only the active supporting and securing devices having an effective stiffness in the relevant direction are to be included and considered to calculate the reaction forces acting on the devices. Small and/or flexible devices such as cleats intended to provide load compression of the packing material are not generally to be included in the calculations called for in S8.6.2e. The number of securing and supporting devices are generally to be the minimum practical whilst taking into account the requirements for redundant provision given in S8.6.2f and S8.6.2g and the available space for adequate support in the hull structure.

S8.6.1c For opening outwards visor doors, the pivot arrangement is generally to be such that the visor is self closing under external loads, that is  $M_y > 0$ . Moreover, the closing moment  $M_y$  as given in S8.3.1c is to be not less than:

$$M_{y0} = 10Wc + 0.1(a^2 + b^2)^{0.5} (F_x^2 + F_z^2)^{0.5}$$

#### S8.6.2 Scantlings

S8.6.2a Securing and supporting devices are to be adequately designed so that they can withstand the reaction forces within the permissible stresses given in S8.2.1a.

S8.6.2b For visor doors the reaction forces applied on the effective securing and supporting devices assuming the door as a rigid body are determined for the following combination of external loads acting simultaneously together with the self weight of the door:

- i) case 1  $F_x$  and  $F_z$
- ii) case 2  $0.7F_y$  acting on each side separately together with  $0.7F_x$  and  $0.7F_z$

where  $F_x$ ,  $F_y$  and  $F_z$  are determined as indicated in S8.3.1b and applied at the centroid of projected areas.

S8.6.2c For side-opening doors the reaction forces applied on the effective securing and supporting devices assuming the door as a rigid body are determined for the following combination of external loads acting simultaneously together with the self weight of the door:

- i) case 1  $F_x$ ,  $F_y$  and  $F_z$  acting on both doors
- ii) case 2  $0.7 F_x$  and  $0.7F_z$  acting on both doors and  $0.7F_y$  acting on each door separately,

## S8 (cont)

where  $F_x$ ,  $F_y$  and  $F_z$  are determined as indicated in S8.3.1b and applied at the centroid of projected areas.

S8.6.2d The support forces as determined according to S8.6.2b i) and S8.6.2c i) shall generally give rise to a zero moment about the transverse axis through the centroid of the area  $A_x$ . For visor doors, longitudinal reaction forces of pin and/or wedge supports at the door base contributing to this moment are not to be of the forward direction.

S8.6.2e The distribution of the reaction forces acting on the securing and supporting devices may require to be supported by direct calculations taking into account the flexibility of the hull structure and the actual position and stiffness of the supports.

S8.6.2f The arrangement of securing and supporting devices in way of these securing devices is to be designed with redundancy so that in the event of failure of any single securing or supporting device the remaining devices are capable to withstand the reaction forces without exceeding by more than 20 per cent the permissible stresses as given in S8.2.1.

S8.6.2g For visor doors, two securing devices are to be provided at the lower part of the door, each capable of providing the full reaction force required to prevent opening of the door within the permissible stresses given in S8.2.1a. The opening moment  $M_o$ , in kN.m, to be balanced by this reaction force, is not to be taken less than:

$$M_o = 10 W d + 5A_x a$$

where:

d vertical distance, in m, from the hinge axis to the centre of gravity of the door, as shown in Figure 2,

a as defined in S8.3.1c.

S8.6.2.h For visor doors, the securing and supporting devices excluding the hinges should be capable of resisting the vertical design force ( $F_z - 10W$ ), in kN, within the permissible stresses given in S8.2.1a.

S8.6.2.i All load transmitting elements in the design load path, from door through securing and supporting devices into the ship structure, including welded connections, are to be to the same strength standard as required for the securing and supporting devices. These elements include pins, supporting brackets and back-up brackets.

S8.6.2j For side-opening doors, thrust bearing has to be provided in way of girder ends at the closing of the two leaves to prevent one leaf to shift towards the other one under effect of unsymmetrical pressure (see example of Figure 3). Each part of the thrust bearing has to be kept secured on the other part by means of securing devices. Any other arrangement serving the same purpose may be proposed.

**S8**  
(cont)**S8.7 Securing and locking arrangement****S8.7.1 Systems for operation**

S8.7.1a Securing devices are to be simple to operate and easily accessible.

Securing devices are to be equipped with mechanical locking arrangement (self locking or separate arrangement), or to be of the gravity type. The opening and closing systems as well as securing and locking devices are to be interlocked in such a way that they can only operate in the proper sequence.

S8.7.1b Bow doors and inner doors giving access to vehicle decks are to be provided with an arrangement for remote control, from a position above the freeboard deck, of:

- the closing and opening of the doors, and
- associated securing and locking devices for every door.

Indication of the open/closed position of every door and every securing and locking device is to be provided at the remote control stations. The operating panels for operation of doors are to be inaccessible to unauthorized persons. A notice plate, giving instructions to the effect that all securing devices are to be closed and locked before leaving harbour, is to be placed at each operating panel and is to be supplemented by warning indicator lights.

S8.7.1c Where hydraulic securing devices are applied, the system is to be mechanically lockable in closed position. This means that, in the event of loss of the hydraulic fluid, the securing devices remain locked.

The hydraulic system for securing and locking devices is to be isolated from other hydraulic circuits, when in closed position.

**S8.7.2 Systems for indication/monitoring**

S8.7.2a Separate indicator lights and audible alarms are to be provided on the navigation bridge and on the operating panel to show that the bow door and inner door are closed and that their securing and locking devices are properly positioned.

The indication panel is to be provided with a lamp test function. It shall not be possible to turn off the indicator light.

S8.7.2b The indicator system is to be designed on the fail safe principle and is to show by visual alarms if the door is not fully closed and not fully locked and by audible alarms if securing devices become open or locking devices become unsecured. The power supply for the indicator system for operating and closing doors is to be independent of the power supply for operating and closing the doors and is to be provided with a back-up power supply from the emergency source of power or other secure power supply e.g. UPS. The sensors of the indicator system are to be protected from water, ice formation and mechanical damage.

Note: The indicator system is considered designed on the fail - safe principal when:

1) The indication panel is provided with:

- a power failure alarm
- an earth failure alarm
- a lamp test
- separate indication for door closed, door locked, door not closed and door not locked.

## S8 (cont)

2) Limit switches electrically closed when the door is closed (when more limit switches are provided they may be connected in series).

3) Limit switches electrically closed when securing arrangements are in place (when more limit switches are provided they may be connected in series).

4) Two electrical circuits (also in one multicore cable), one for the indication of door closed / not closed and the other for door locked / not locked.

5) In case of dislocation of limit switches, indication to show: not closed / not locked / securing arrangement not in place - as appropriate.

S8.7.2c The indication panel on the navigation bridge is to be equipped with a mode selection function "harbour/sea voyage", so arranged that audible alarm is given on the navigation bridge if the vessel leaves harbour with the bow door or inner door not closed or with any of the securing devices not in the correct position.

S8.7.2d A water leakage detection system with audible alarm and television surveillance is to be arranged to provide an indication to the navigation bridge and to the engine control room of leakage through the inner door.

Note: The indicator system is considered designed on the fail - safe principal when:

1) The indication panel is provided with:

- a power failure alarm
- an earth failure alarm
- a lamp test
- separate indication for door closed, door locked, door not closed and door not locked.

2) Limit switches electrically closed when the door is closed (when more limit switches are provided they may be connected in series).

3) Limit switches electrically closed when securing arrangements are in place (when more limit switches are provided they may be connected in series).

4) Two electrical circuits (also in one multicore cable), one for the indication of door closed / not closed and the other for door locked / not locked.

5) In case of dislocation of limit switches, indication to show: not closed / not locked / securing arrangement not in place - as appropriate.

S8.7.2e Between the bow door and the inner door a television surveillance system is to be fitted with a monitor on the navigation bridge and in the engine control room. The system is to monitor the position of the doors and a sufficient number of their securing devices. Special consideration is to be given for the lighting and contrasting colour of objects under surveillance.

Note: The indicator system is considered designed on the fail - safe principal when:

1) The indication panel is provided with:

- a power failure alarm
- an earth failure alarm
- a lamp test

**S8**  
**(cont)**

- separate indication for door closed, door locked, door not closed and door not locked.
- 2) Limit switches electrically closed when the door is closed (when more limit switches are provided they may be connected in series).
- 3) Limit switches electrically closed when securing arrangements are in place (when more limit switches are provided they may be connected in series).
- 4) Two electrical circuits (also in one multicore cable), one for the indication of door closed / not closed and the other for door locked / not locked.
- 5) In case of dislocation of limit switches, indication to show: not closed / not locked / securing arrangement not in place - as appropriate.

S8.7.2f A drainage system is to be arranged in the area between bow door and ramp, or where no ramp is fitted, between the bow door and inner door. The system is to be equipped with an audible alarm function to the navigation bridge being set off when the water levels in these areas exceed 0.5m or the high water level alarm, whichever is lesser.

Note: The indicator system is considered designed on the fail - safe principal when:

- 1) The indication panel is provided with:
  - a power failure alarm
  - an earth failure alarm
  - a lamp test
  - separate indication for door closed, door locked, door not closed and door not locked.
- 2) Limit switches electrically closed when the door is closed (when more limit switches are provided they may be connected in series).
- 3) Limit switches electrically closed when securing arrangements are in place (when more limit switches are provided they may be connected in series).
- 4) Two electrical circuits (also in one multicore cable), one for the indication of door closed / not closed and the other for door locked / not locked.
- 5) In case of dislocation of limit switches, indication to show: not closed / not locked / securing arrangement not in place - as appropriate.

S8.7.2.g For ro-ro passenger ships on international voyages, the special category spaces and ro-ro spaces are to be continuously patrolled or monitored by effective means, such as television surveillance, so that any movement of vehicles in adverse weather conditions or unauthorized access by passengers thereto, can be detected whilst the ship is underway.

**S8**  
(cont)**S8.8 Operating and Maintenance Manual**

S8.8.1 An Operating and Maintenance Manual for the bow door and inner door is to be provided on board and is to contain necessary information on:

- main particulars and design drawings
  - special safety precautions
  - details of vessel
  - equipment and design loading (for ramps)
  - key plan of equipment (doors and ramps)
  - manufacturer's recommended testing for equipment
  - description of equipment for
    - bow doors
    - inner bow doors
    - bow ramp/doors
    - side doors
    - stern doors
    - central power pack
    - bridge panel
    - engine control room panel
- service conditions
  - limiting heel and trim of ship for loading/unloading
  - limiting heel and trim for door operations
  - doors/ramps operating instructions
  - doors/ramps emergency operating instructions
- maintenance
  - schedule and extent of maintenance
  - trouble shooting and acceptable clearances
  - manufacturer's maintenance procedures
- register of inspections, including inspection of locking, securing and supporting devices, repairs and renewals.

This Manual is to be submitted for approval that the above mentioned items are contained in the OMM and that the maintenance part includes the necessary information with regard to inspections, troubleshooting and acceptance / rejection criteria.

Note: It is recommended that recorded inspections of the door supporting and securing devices be carried out by the ship's staff at monthly intervals or following incidents that could result in damage, including heavy weather or contact in the region of the shell doors. Any damages recorded during such inspections are to be reported to the Classification Society.

S8.8.2 Documented operating procedures for closing and securing the bow door and inner door are to be kept on board and posted at appropriate place.

**S8**  
(cont)

Fig. 1 Definition of  $\alpha$  and  $\beta$

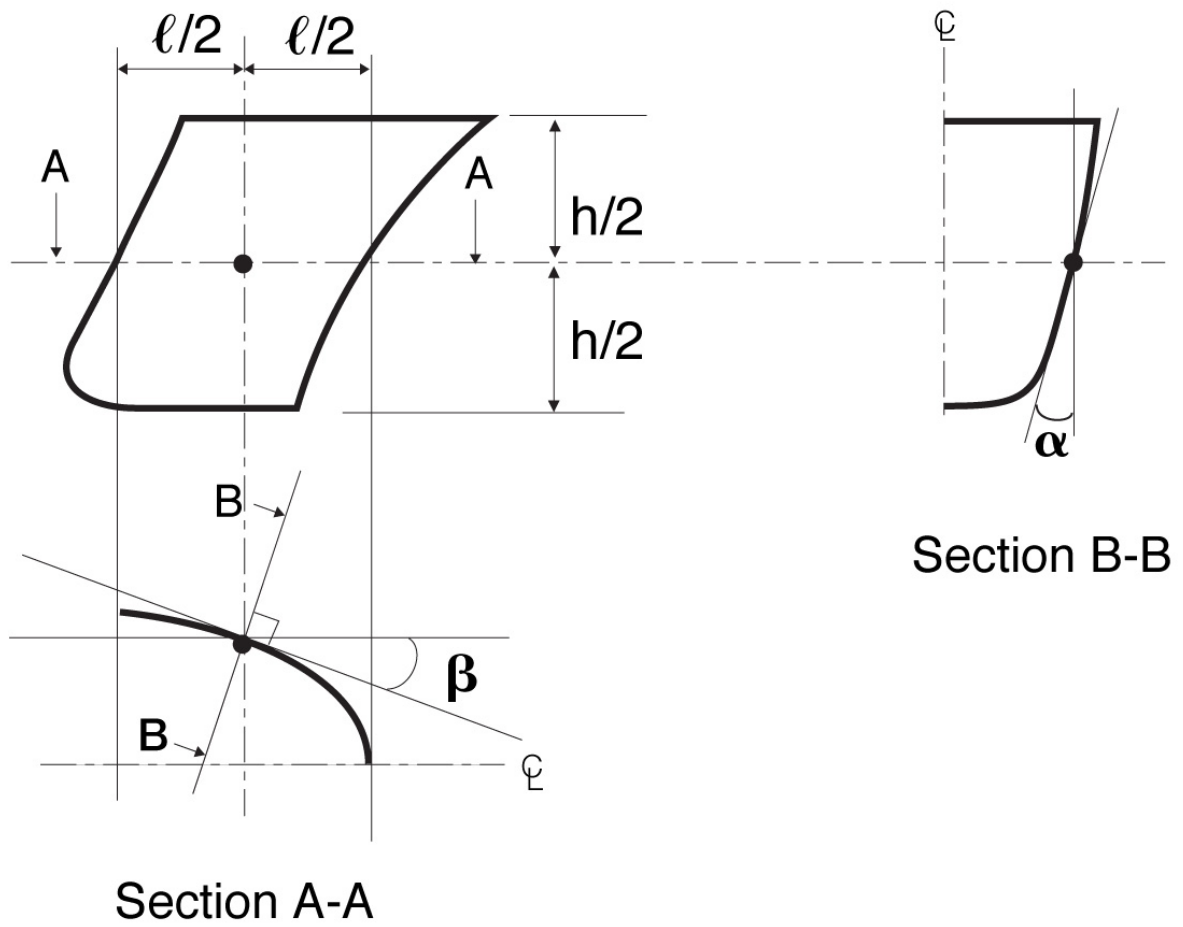

**S8**  
(cont)

**Fig. 2 Bow Door of Visor Type**

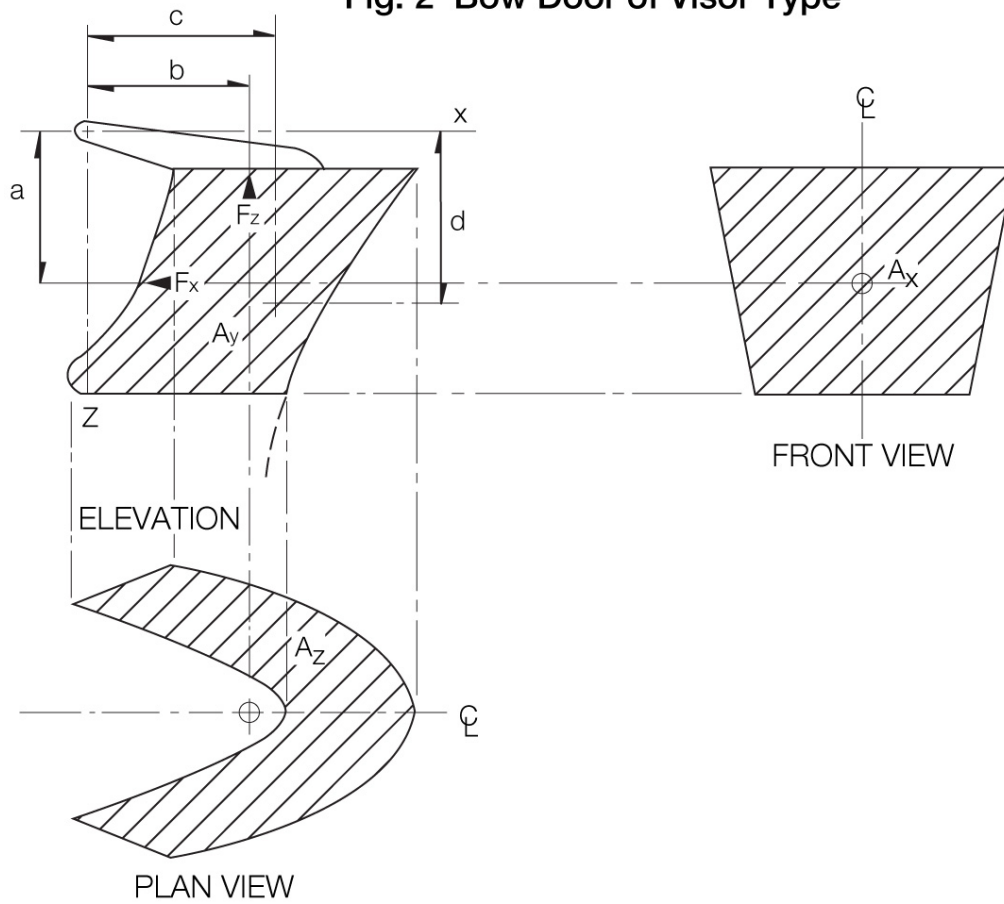

**Fig. 3 Thrust Bearing**

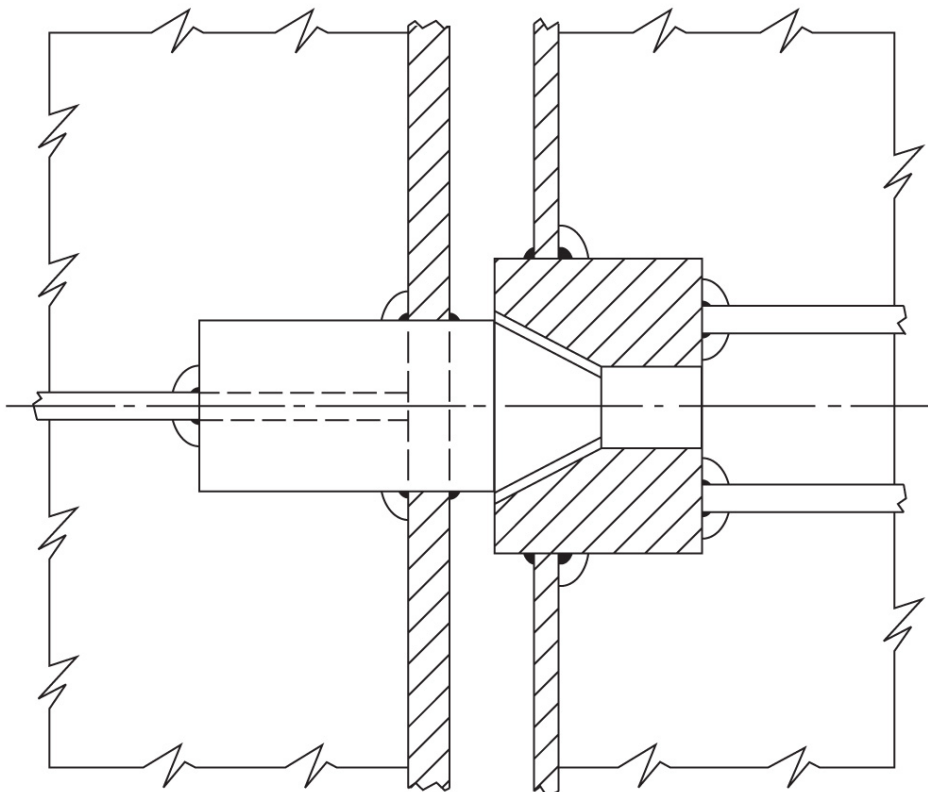

End of Document